

Seismic Restraints Cent-R-Rail® Supplement*

Multi-Directional Bracing For Data-Track®, Half-Rack® and Multi-Tier Half-Rack® Systems

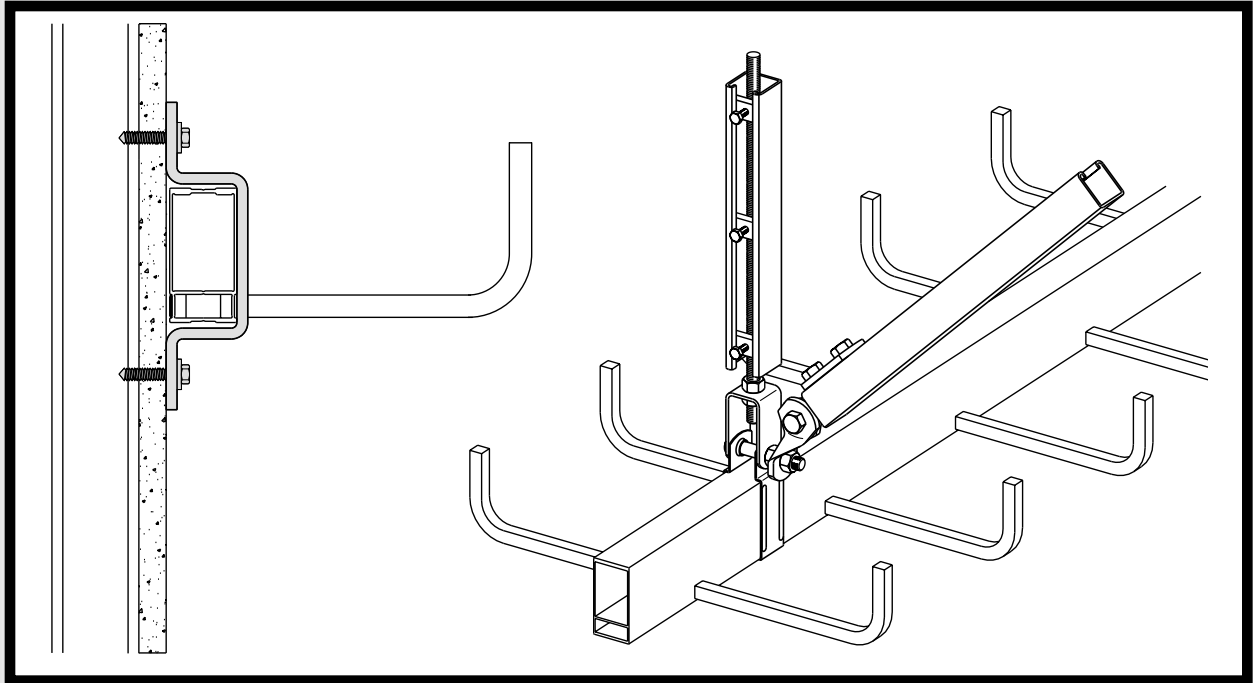

PENDING OSHPD APPROVAL

Raafat S. Aboulhosn

Structural Engineer

S 3913

*To be used in conjunction with Cooper B-Line's
"Seismic Restraints" Brochure (SRS-00)

B-Line®

SYSTEMS THAT MAKE SENSE



COOPER B-Line

TABLE OF CONTENTS

General Information and Notes	3
Cent-R-Rail® Bracing Selection Procedure	4
Data-Track® Bracing Details	5-8
Data-Track® Bracing Schedules	9-10
Data-Track® Attachments to Structure	11-12
Data-Track® Uneven Loading Supports	13
Half-Rack® Mounting Details	14-16
Multi-Tier Half-Rack® Mounting Details	17-20
Anchoring Notes	21-22

IMPORTANT

This document contains bracing details, selection procedures, and spacing tables for the Cent-R-Rail® system cable trays listed. It serves as a supplement to the previously approved B-Line Seismic Restraints brochure (SRS-00) R-0114 dated SEP 22, 1994.



PENDING OSHPD APPROVAL

Cooper B-Line, Inc.

509 West Monroe Street
Highland, Illinois 62249

Phone : 618-654-2184
Fax : 618-654-1917

B-Line

Raafat S. Aboulhosen

Structural Engineer

S 3913

Page No.

Date:

Sheet Number:

2

10 - 9 - 97

___ of ___

GENERAL INFORMATION

B-Line Seismic Restraint Systems are designed to resist seismic loading in any direction while minimizing installation time and providing superior performance. On the following pages, several methods of seismically bracing Cent-R-Rail are illustrated. The choice of brace design should be governed by the system requirements and location of supports. A section on how to select seismic restraints is located on page 4.

Actual applications may vary and are not strictly limited to the combinations of fittings and supports shown. Any changes to the depicted designs should be in accordance with standard engineering practices and meet the specific project requirements. Certain projects in California must also be approved by OSHPD (California Office of Statewide Health Planning & Development).

For information on other styles of hangers, fittings, and miscellaneous hardware, see the latest version of B-Line's Strut Systems Catalog or Cent-R-Rail® Catalog.

The details shown in this document are based on the California Code of Regulations Title 24, Part 2 requirements for hospitals and essential facilities in seismic zone 4. Essential facilities are those structures which are necessary for emergency post-earthquake operations. See CCR, Title 24, Part 2, Table 23-K for a list of the types of essential facilities.

As per the **California Code of Regulations, Title 24, Part 2**, seismic restraints are required on piping, electrical conduit, cable trays and air handling ducts. These regulations state that for the rigidly supported piping, electrical conduits, cable trays or air handling ducts, the seismic restraints shall be capable of supporting a horizontal force of **0.45 G**.

General Notes For Seismic Bracing

- A). The seismic restraint assemblies shown in this document are designed to resist vertical loading simultaneously with seismic loading (transverse & longitudinal loading).
- B). Channel brace length shall not exceed 9'-4".
- C). Transverse and longitudinal braces shall be no more than 45° above or below the centerline of the cable tray.
- D). All channel nuts and bolts shall be tightened to the following torques: 1/4" - 6 ft.-lbs.; 3/8" - 19 ft.-lbs.; 1/2" - 50 ft.-lbs.
- E). Transverse and longitudinal bracing shall be spaced in accordance with the applicable table for the cable tray type.
- F). The cable tray system should not be braced to parts of a building that may respond differently during an earthquake. Example: Solid concrete wall and a roof (metal deck filled with lightweight concrete).
- G). Transverse bracing for one cable tray section may also act as longitudinal bracing for the cable tray section connected to it, if the bracing is installed within 24 inches of the elbow or tee.
- H). Rod stiffeners (if required) need only be installed on seismically braced support locations.

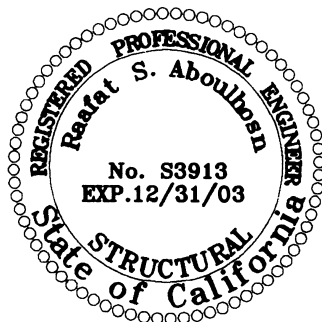

B-Line Systems, Inc.

509 West Monroe Street Phone :618-654-2184
Highland, Illinois 62249 Fax : 618-654-1917



Raafat S. Aboulhosen

Structural Engineer

S 3913

PENDING OSHPD APPROVAL

Page No.

Date:

Sheet Number:

3

10 - 9 - 97

___ of ___

BRACING SELECTION PROCEDURE

- 1). Determine which system is to be used:
Data-Track®, Half-Rack®, or Multi-Tier Half-Rack®
(See Cent-R-Rail® Catalog for fill data, load ratings, and dimensional information.)

For Data-Track Systems:

- 2). Determine total cable tray loading in lbs./ft.
- 3). Select bracing details from pages 5-8.
- 4). Find structure connection type (anchor size), and maximum support spacing:
For cable trays up to 12" wide use Table 1 - page 9.
For cable trays greater than 12" wide use Table 2 - page 10.
- 5). For unevenly loaded cable trays, select applicable support method from Table 5 - page 13.
- 6). Determine if rod stiffeners are required: Maximum length for 1/2"-13 rod without requiring a rod stiffener is 25". If rod is greater than 25" use rod stiffener detail on page 18 of SRS-1R. Rod stiffeners (if required) need only be installed on seismically braced support locations.
- 7). Review the design.

For Half-Rack and Multi-Tier Half-Rack Systems:

- 2). Determine total tray loading in lbs./ft.
- 3). Select support details from pages 14-20.
- 4). Find maximum support spacing from detail tables.
- 5). Review the design.

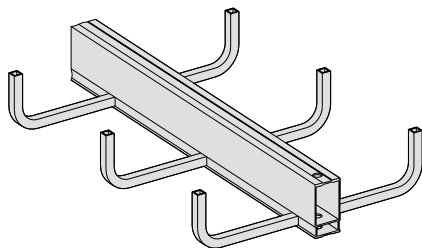

Data-Track®

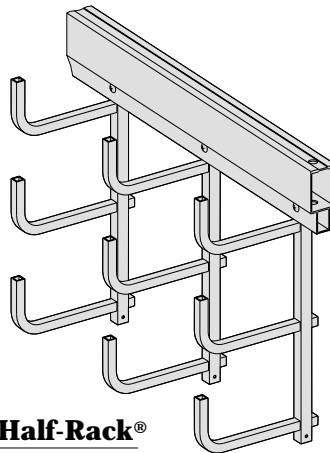

Multi-Tier Half-Rack®

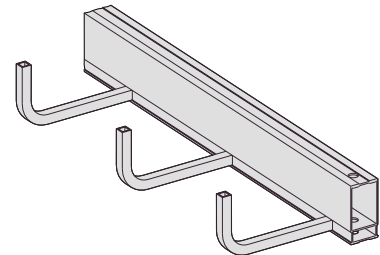

Half-Rack®



PENDING OSHPD APPROVAL

Cooper B-Line, Inc.

509 West Monroe Street
Highland, Illinois 62249

Phone : 618-654-2184
Fax : 618-654-1917

B-Line

Raafat S. Aboulhoss

Structural Engineer

S 3913

Page No.

4

Date:

10 - 9 - 97

Sheet Number:

___ of ___

DATA-TRACK® BRACING DETAILS

Longitudinal & Transverse Bracing: Using Connector Bolt Holes

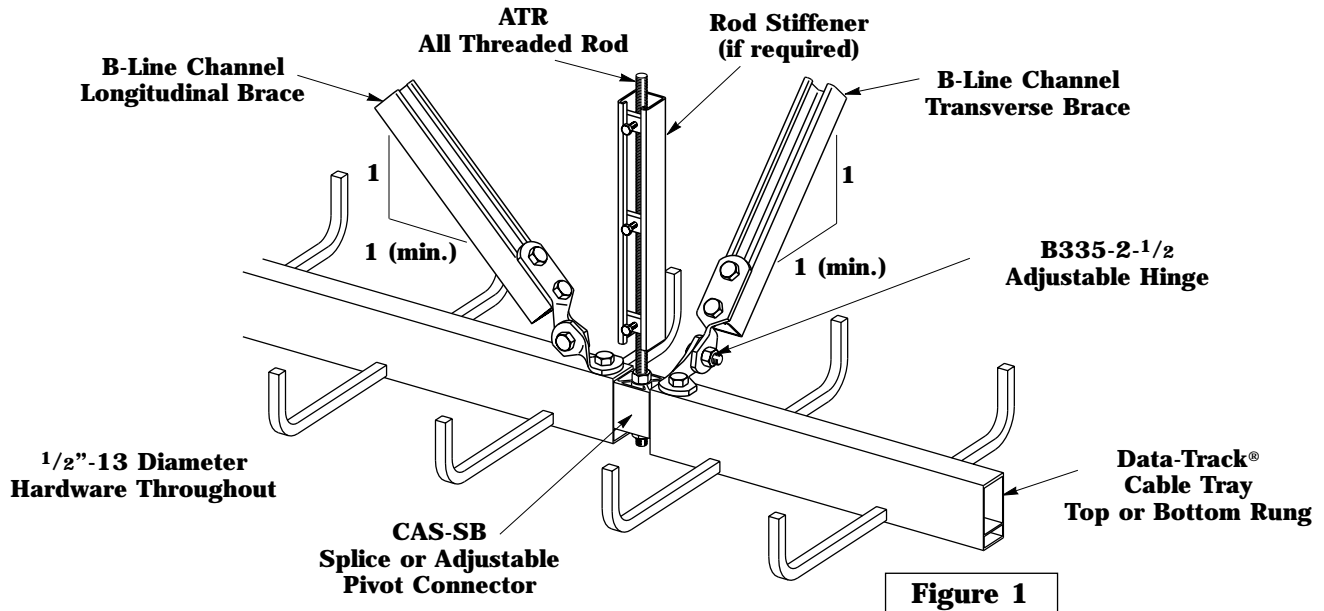

Figure 1

- Notes:**
- 1). Important: When one or both adjustable hinges are attached to the splice or adjustable pivot connector, a longer (1/2" x 3" min.) bolt must be used (not included).
 - 2). Either brace may be removed to form a longitudinal brace only or a transverse brace only, if desired.
 - 3). Both adjustable hinges may be attached to the same bolt as shown in Figure 2 below. (Rod removed for clarity.)
 - 4). Either hinge (or both) may be attached to the all threaded rod instead of the connector bolt as shown in Figure 3.
 - 5). B-Line channel is type B22 or B22SH. (See SRS-1R pages 12 & 19 for load data.)
 - 6). Note the position of longitudinal bracing when selecting hanger rod locations.

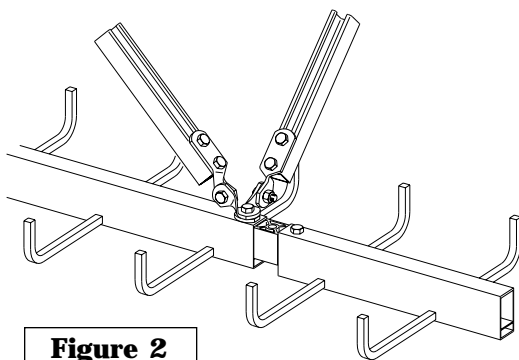

Figure 2

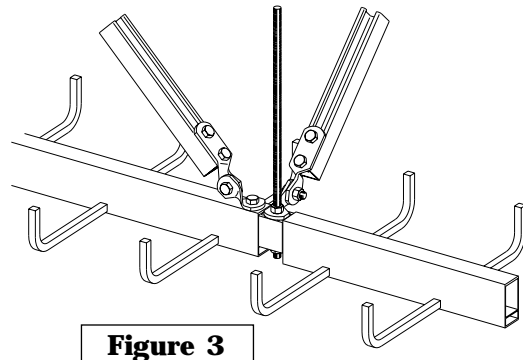
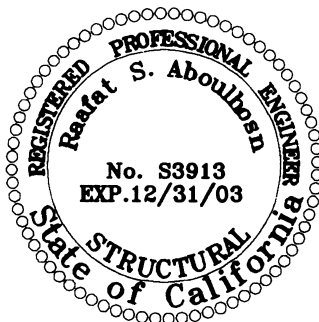

Figure 3



PENDING OSHPD APPROVAL

Cooper B-Line, Inc.

509 West Monroe Street
Highland, Illinois 62249

Phone :618-654-2184
Fax : 618-654-1917

B-Line

Raafat S. Aboulhosen

Structural Engineer

S 3913

Page No.

5

Date:

10 - 9 - 97

Sheet Number:

___ of ___

DATA-TRACK® BRACING DETAILS

Longitudinal & Transverse Bracing: Drill-Through Method

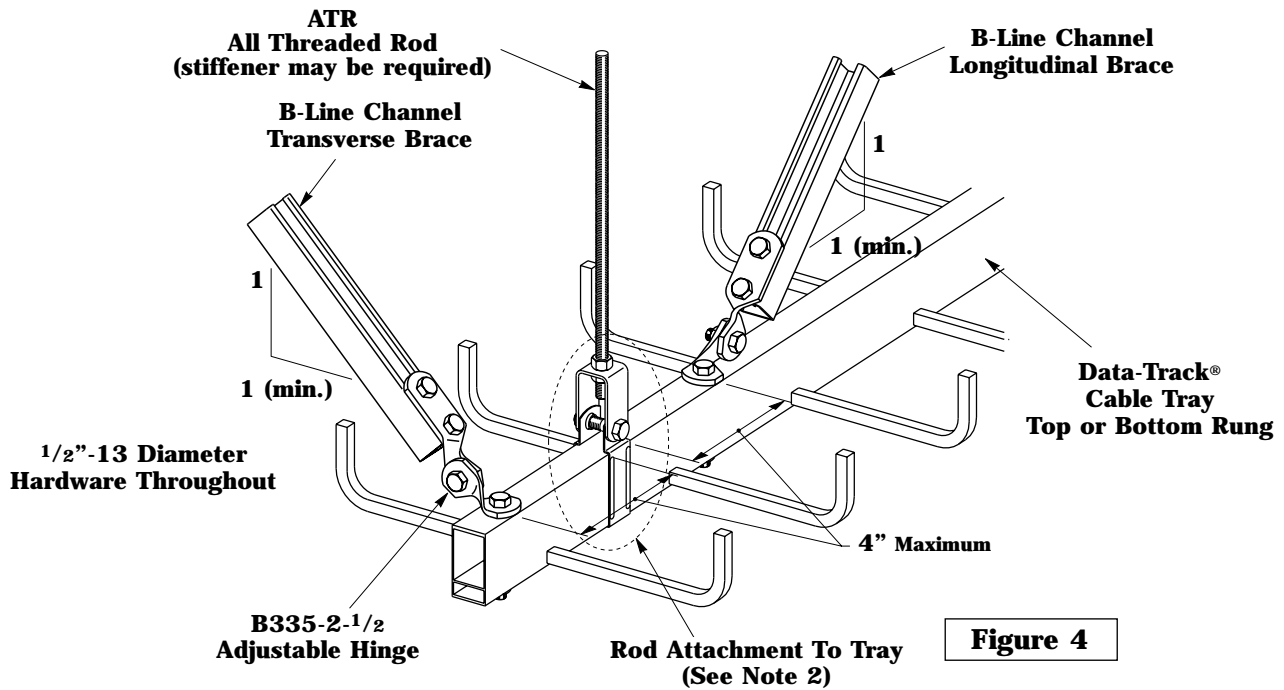

Figure 4

- Notes:**
- 1). Important: When one or both adjustable hinges are attached to the cable tray, a 1/2" x 4" (min.) bolt must be used (not included).
 - 2). Rod attachment to tray may include CZNH-CD clevis hanger (shown in Figure 4), CAS-SB splice connector, ATR through field drilled holes, or other methods per B-Line recommendations.
 - 3). Either brace may be removed to form a longitudinal brace only or a transverse brace only, if desired.
 - 4). Both adjustable hinges may be attached to the same bolt as shown in Figure 5.
 - 5). B-Line channel is type B22 or B22SH. (See SRS-1R pages 12 & 19 for load data.)
 - 6). Note the position of longitudinal bracing when selecting hanger rod locations.

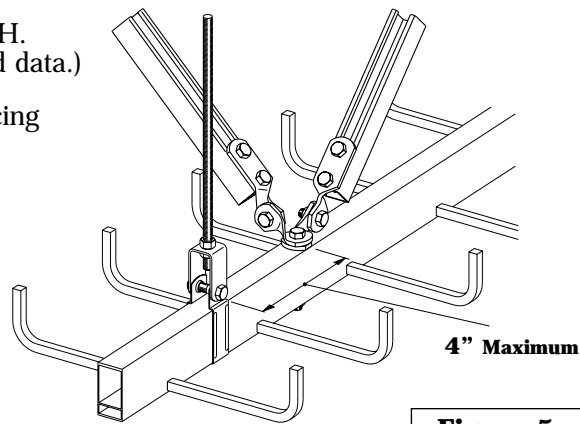

Figure 5



PENDING OSHPD APPROVAL

Cooper B-Line, Inc.

509 West Monroe Street
Highland, Illinois 62249

Phone : 618-654-2184
Fax : 618-654-1917

B-Line

Raafat S. Aboulhoss

Structural Engineer

S 3913

Page No.

6

Date:

10 - 9 - 97

Sheet Number:

___ of ___

DATA-TRACK® BRACING DETAILS

Transverse Braces Using CZNH-CD Clevis Hanger

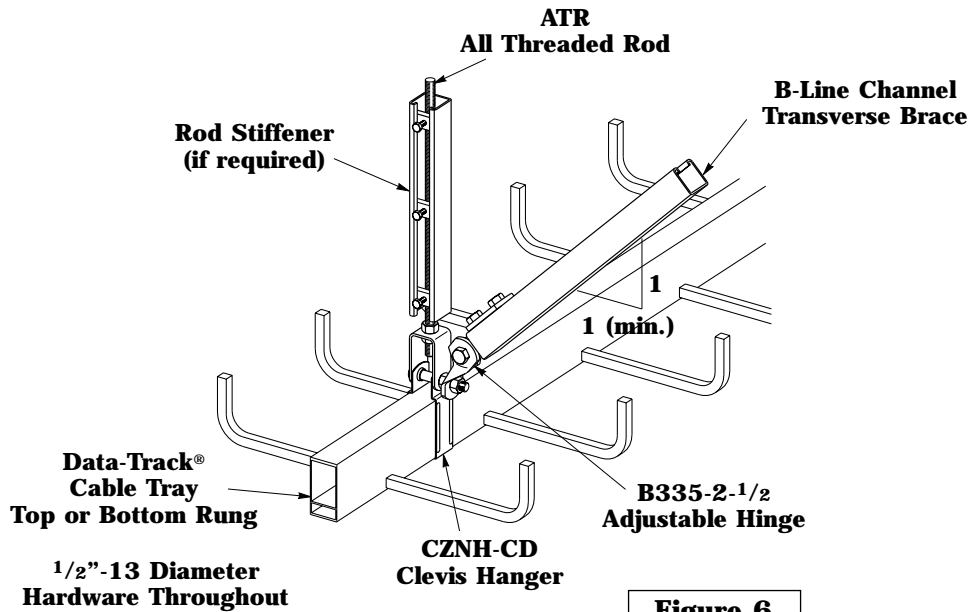
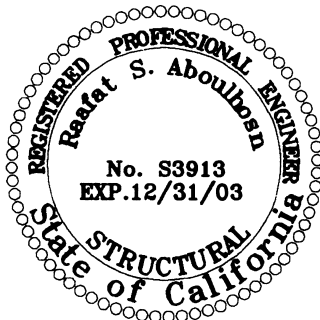

Figure 6

- Notes:**
- 1). Important: When attaching bracing to the CZNH-CD clevis hanger, a longer bolt (1/2" x 3" min.) must be used (not included).
 - 2). B-Line channel is type B22 or B22SH. (See SRS-1R pages 12 & 19 for load data.)



PENDING OSHPD APPROVAL

Cooper B-Line, Inc.

509 West Monroe Street
Highland, Illinois 62249

Phone :618-654-2184
Fax : 618-654-1917

B-Line

Raafat S. Aboulhosen

Structural Engineer

S 3913

Page No.

7

Date:

10 - 9 - 97

Sheet Number:

___ of ___

DATA-TRACK® BRACING DETAILS

Longitudinal or Transverse Bracing: Using CAM-DSC Seismic Clamp

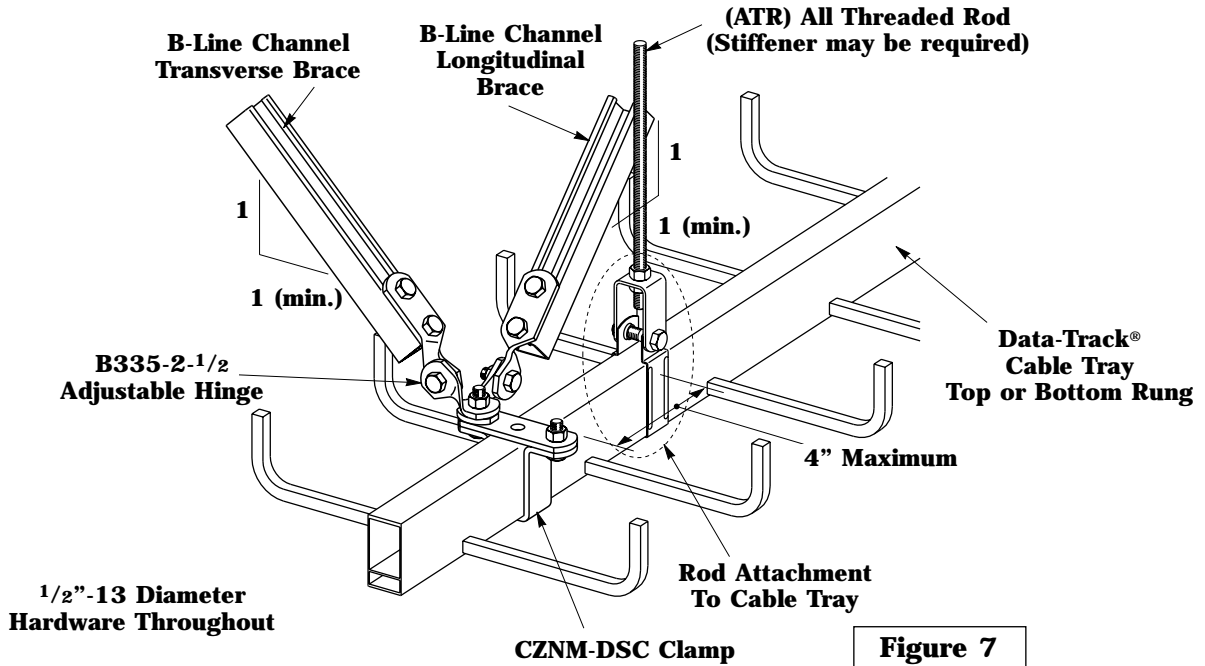

Figure 7

- Notes:**
- 1). Rod attachment to tray may include CZNH-CD clevis hanger (shown in Figure 7), CAS-SB splice connector, ATR through field drilled holes, or other methods per B-Line recommendations.
 - 2). Either brace may be removed to form a longitudinal brace only or a transverse brace only, if desired.
 - 3). The adjustable hinges may be attached to different CZNM-DSC bolts as shown in Figure 8 below.
 - 4). B-Line channel is type B22 or B22SH. (See SRS-1R pages 12 & 19 for load data.)

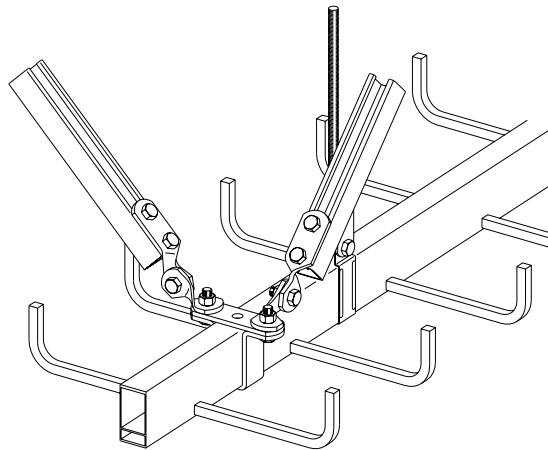

Figure 8



PENDING OSHPD APPROVAL

Cooper B-Line, Inc.

509 West Monroe Street
Highland, Illinois 62249

Phone : 618-654-2184
Fax : 618-654-1917

B-Line

Raafat S. Aboulhoss

Structural Engineer

S 3913

Page No.

Date:

Sheet Number:

8

10 - 9 - 97

___ of ___

Table 1

Data-Track Bracing Schedule - For 12" Wide Cable Tray And Under

Total Cable Loading (lbs./ft.)	Structure Connection Type ¹	Maximum Allowable Load Split ²	Maximum Transverse Support Spacing (ft.) ³	Maximum Longitudinal Support Spacing (ft.) ³	Maximum Vertical Hanger Rod Spacing (ft.) ⁴
0-10 lbs./ft.	I	100/0	12	27	12
	II	100/0	20	46	12
	III	100/0	31	70	12
10.01-25 lbs./ft.	II	100/0	8	18	12
	III	100/0	12	28	12
	IV	100/0	18	42	12
	V	100/0	27	61	12
25.01-50 lbs./ft.	IV	80/20	10	20	12
	V	80/20	15	30	12
50.01-75 lbs./ft.	IV	60/40	9	13	6
	V	60/40	14	20	6
75.01-100 lbs./ft.	V	50/50	12	15	6

Notes:

- 1). See pages 11-12 for structure connection details and pages 21-22 for anchor notes.
- 2). Load split example: 100/0 = Total weight of cables on one side.

50/50 = Weight of cables equally divided on both sides.

IMPORTANT: This chart gives the maximum allowable load split for seismic calculation purposes only. Additional vertical hanger rod support methods may be required depending on the actual amount of uneven loading. See page 13.

- 3). Maximum support spacings are to be rounded down to nearest vertical hanger rod location. Bracing must be installed within 4" of vertical hanger rod as shown in the bracing details.
- 4). Vertical hangers may consist of CZNH-CD clevis hangers, CAS-SB splice connectors, ATR through field drilled holes in the tray center rail, or other methods per B-Line recommendations.



PENDING OSHPD APPROVAL

Cooper B-Line, Inc.

509 West Monroe Street Phone :618-654-2184
Highland, Illinois 62249 Fax : 618-654-1917

B-Line

Raafat S. Aboulhosen

Structural Engineer

S 3913

Page No.

9

Date:

10 - 9 - 97

Sheet Number:

___ of ___

DATA-TRACK® SCHEDULES

Table 2

Data-Track Bracing Schedule - For 18" & 24" Wide Cable Tray

Total Cable Loading (lbs./ft.)	Structure Connection Type ¹	Maximum Allowable Load Split ²	Maximum Transverse Support Spacing (ft.) ³	Maximum Longitudinal Support Spacing (ft.) ³	Maximum Vertical Hanger Rod Spacing (ft.) ⁴
0-10 lbs./ft.	II	100/0	15	46	12
	III	100/0	22	70	12
	IV	100/0	34	80	12
10.01-25 lbs./ft.	III	100/0	9	28	12
	IV	100/0	13	42	12
	V	100/0	19	61	12
25.01-50 lbs./ft.	V	80/20	12	30	12
50.01-75 lbs./ft.	V	60/40	12	20	6
75.01-100 lbs./ft.	V	50/50	12	15	6

Notes:

- 1). See pages 11-12 for structure connection details and pages 21-22 for anchor notes.
- 2). Load split example: 100/0 = Total weight of cables on one side.

50/50 = Weight of cables equally divided on both sides.

IMPORTANT: This chart gives the maximum allowable load split for seismic calculation purposes only. Additional vertical hanger rod support methods may be required depending on the actual amount of uneven loading. See page 13.

- 3). Maximum support spacings are to be rounded down to nearest vertical hanger rod location. Bracing must be installed within 4" of vertical hanger rod as shown in the bracing details.
- 4). Vertical hangers may consist of CZNH-CD clevis hangers, CAS-SB splice connectors, ATR through field drilled holes in the tray center rail, or other methods per B-Line recommendations.



PENDING OSHPD APPROVAL

Cooper B-Line, Inc.

509 West Monroe Street
Highland, Illinois 62249

Phone : 618-654-2184
Fax : 618-654-1917

B-Line

Raafat S. Aboulhosen

Structural Engineer

S 3913

Page No.

10

Date:

10 - 9 - 97

Sheet Number:

___ of ___

ATTACHMENTS TO STRUCTURE

Table 3

Anchorage Schedule

Structure Connection Type (See Tables 1 & 2)	Anchor Thread Diameter*							
	Essential Bldgs. Hilti Kwik Bolt II In 3000 psi Hardrock Concrete		Other Than Essential Bldgs. Hilti Kwik Bolt II In 3000 psi Hardrock Concrete		Cast-In Place Anchors		Wood Attachment 4" Bolt Thru Beam	
	STRUCTURE ATTACHMENT DETAILS							
	Detail 1	Detail 2	Detail 1	Detail 2	Detail 1	Detail 2	Detail 3	Detail 4
I	3/8"	3/8"	3/8"	3/8"	3/8"	3/8"	1/2"	1/2"
II	1/2"	3/8"	3/8"	3/8"	1/2"	3/8"	3/4"	1/2"
III	5/8"	1/2"	1/2"	3/8"	5/8"	1/2"	1"	5/8"
IV	3/4"	1/2"	5/8"	1/2"	3/4"	5/8"	--	3/4"
V	--	3/4"	--	5/8"	3/4"	5/8"	--	1"

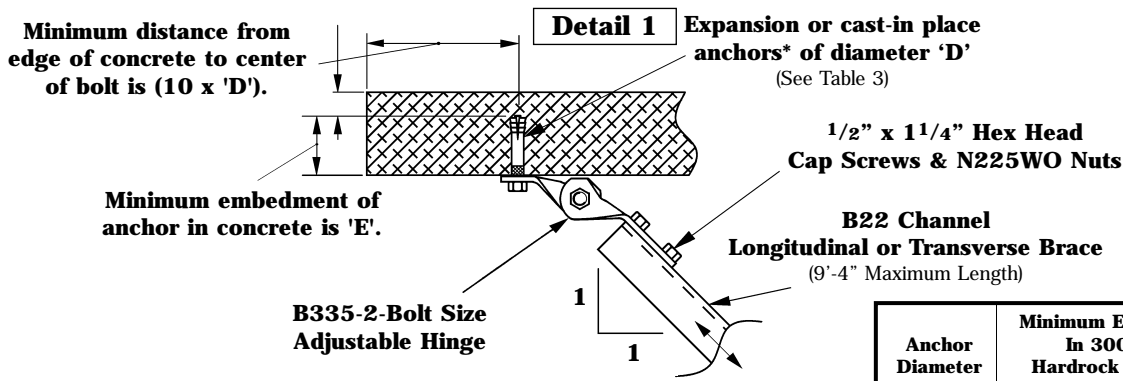

*See anchor notes on pages 21-22.

Anchor Diameter 'D'	Minimum Embedment In 3000 psi Hardrock Concrete 'E'	Minimum Distance Between Anchors 'X'
3/8"	2 1/2"	4 1/2"
1/2"	3 1/2"	6"
5/8"	4"	7 1/2"
3/4"	4 3/4"	9"

Detail 2

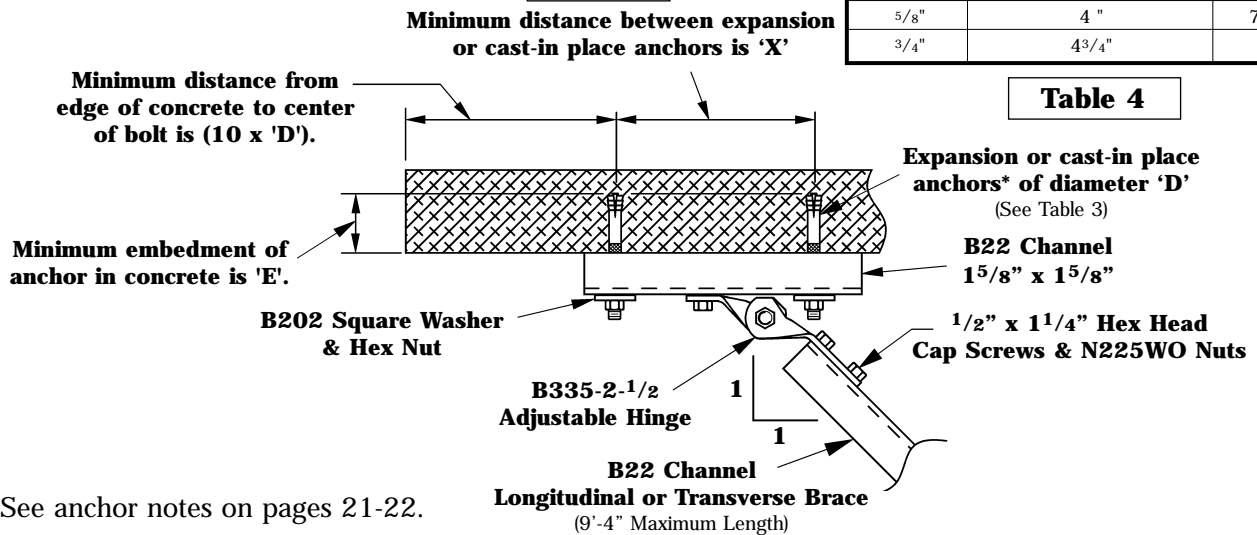

*See anchor notes on pages 21-22.

Table 4



PENDING OSHPD APPROVAL

Cooper B-Line, Inc.

509 West Monroe Street
Highland, Illinois 62249

Phone : 618-654-2184
Fax : 618-654-1917

B-Line

Raafat S. Aboulhosen

Structural Engineer

S 3913

Page No.

11

Date:

10 - 9 - 97

Sheet Number:

___ of ___

ATTACHMENTS TO STRUCTURE

Wood Beam Attachment

Detail 3

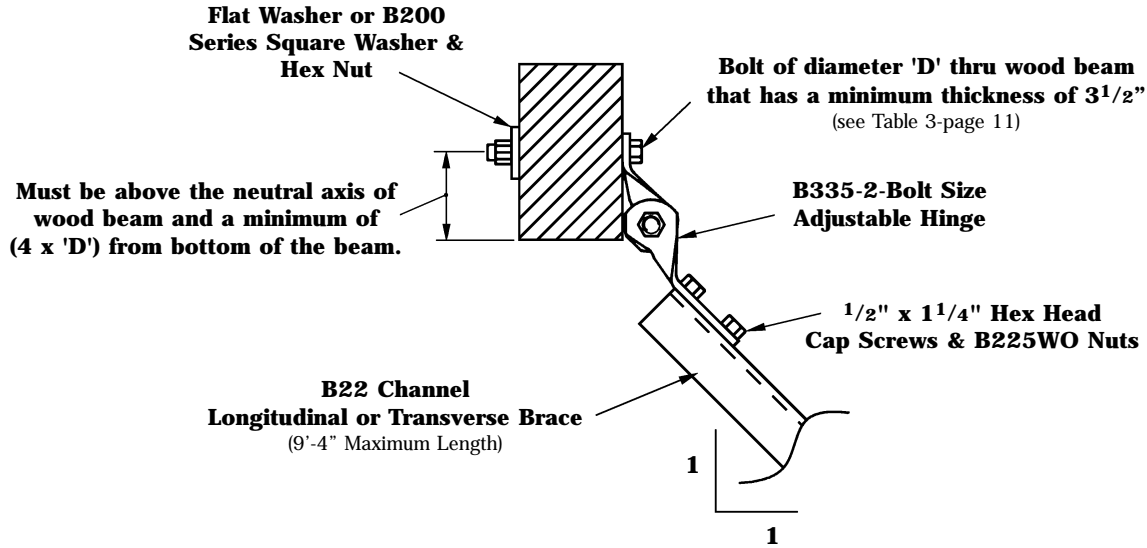

Note: See load data on Table 3-page 11.

Wood Beam Attachment

Detail 4

Used where brace runs parallel to wood beam or where double bolts are required.

4" x 6" x 3/8" steel angle mounted to wood beam with two bolts of diameter 'D' that are a minimum of (4 x 'D') on centers. Bolt holes are centered in 4" side of angle. (see Table 3-page 11)

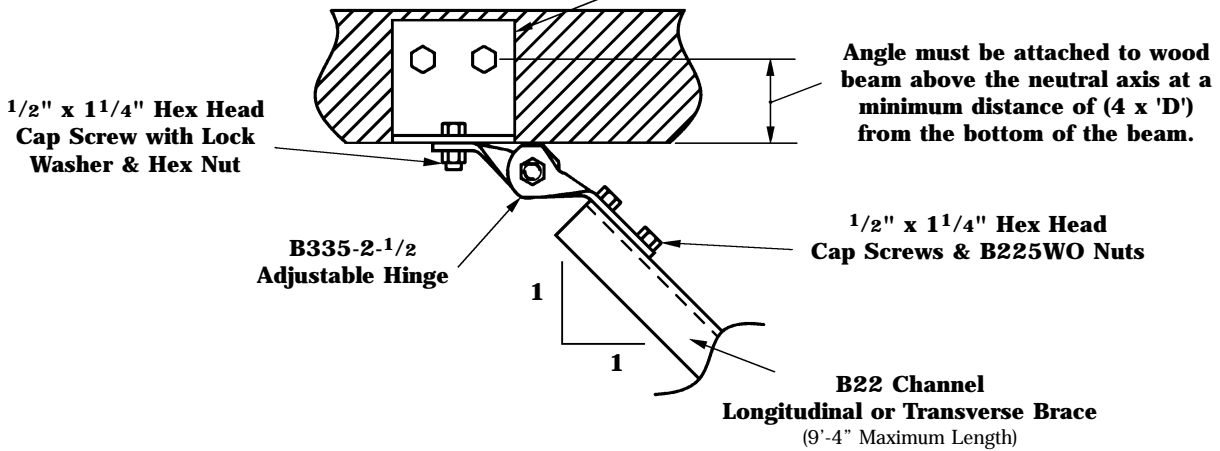

Note: See load data on Table 3-page 11.



PENDING OSHPD APPROVAL

Cooper B-Line, Inc.

509 West Monroe Street
Highland, Illinois 62249

Phone : 618-654-2184
Fax : 618-654-1917

B-Line

Raafat S. Aboulhosen

Structural Engineer

S 3913

Page No.

Date:

Sheet Number:

12

10 - 9 - 97

___ of ___

Table 5

Data-Track Uneven Loading Supports

Cable Tray Support Method

Allowable* Load Split

	12" Wide Data-Track® & less	18" & 24" Wide Data-Track®
<u>Loads between 0-10 lbs./ft.</u>		
Detail 1: 1/2" all thread rod with hex nuts on top and bottom of cable tray, splice or fitting	100/0	75/25
Detail 2: 1/2" all thread rod with CZNH-CD clevis hanger	80/20	67/33
Detail 3: 1/2" all thread rod stiffened with B22 and SC228's	100/0	90/10
Detail 4: 2-1/2" all thread rods connected with B107's	100/0	100/0
Detail 5: Transverse bracing attachment within 4" of any vertical hanger rod	100/0	100/0
<u>Loads between 10.01 and 25 lbs./ft.</u>		
Detail 1: 1/2" all thread rod with hex nuts on top and bottom of cable tray, splice or fitting	90/10	65/35
Detail 2: 1/2" all thread rod with CZNH-CD clevis hanger	70/30	65/35
Detail 3: 1/2" all thread rod stiffened with B22 and SC228's	100/0	80/20
Detail 4: 2-1/2" all thread rods connected with B107's	100/0	100/0
Detail 5: Transverse bracing attachment within 4" of any vertical hanger rod	100/0	100/0
<u>Loads between 25.01 and 50 lbs./ft.</u>		
Detail 1: 1/2" all thread rod with hex nuts on top and bottom of cable tray, splice or fitting	70/30	60/40
Detail 2: 1/2" all thread rod with CZNH-CD clevis hanger	65/35	55/45
Detail 3: 1/2" all thread rod stiffened with B22 and SC228's	75/25	65/35
Detail 4: 2-1/2" all thread rods connected with B107's	80/20	80/20
Detail 5: Transverse bracing attachment within 4" of any vertical hanger rod	80/20	80/20
<u>Loads between 50.01 and 75 lbs./ft.</u>		
Detail 1: 1/2" all thread rod with hex nuts on top and bottom of cable tray, splice or fitting	55/45	55/45
Detail 2: 1/2" all thread rod with CZNH-CD clevis hanger	55/45	55/45
Detail 3: 1/2" all thread rod stiffened with B22 and SC228's	60/40	60/40
Detail 4: 2-1/2" all thread rods connected with B107's	60/40	60/40
Detail 5: Transverse bracing attachment within 4" of any vertical hanger rod	60/40	60/40
<u>Loads between 75.01 and 100 lbs./ft.-load evenly</u>	50/50	50/50

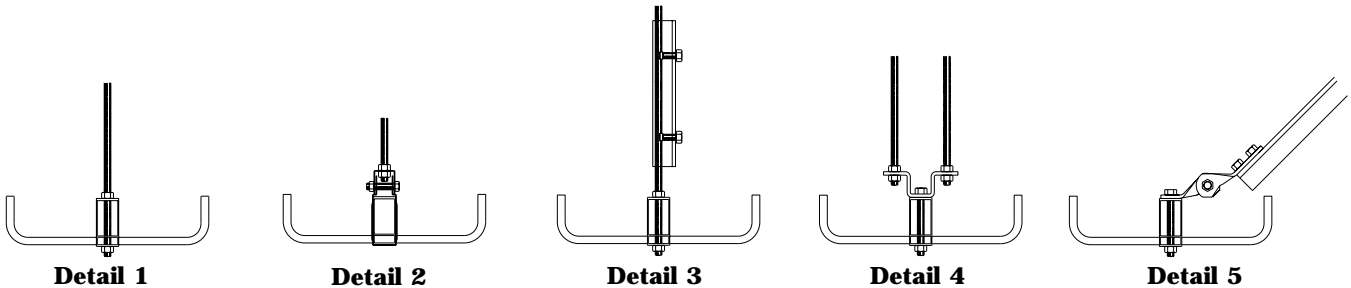

* Criteria based on a 6 degree tilt of the tray with respect to the horizontal. Tests were performed on single sections of cable tray with a span of 12' between supports. Maximum hanger rod length tested was 6'.



PENDING OSHPD APPROVAL

Cooper B-Line, Inc.

509 West Monroe Street
Highland, Illinois 62249

Phone :618-654-2184
Fax : 618-654-1917

B-Line

Raafat S. Aboulhosen

Structural Engineer

S 3913

Page No.

Date:

Sheet Number:

13

10 - 9 - 97

___ of ___

HALF-RACK® MOUNTING DETAILS

CZNH-WH Wall Hanger: In Concrete Slab

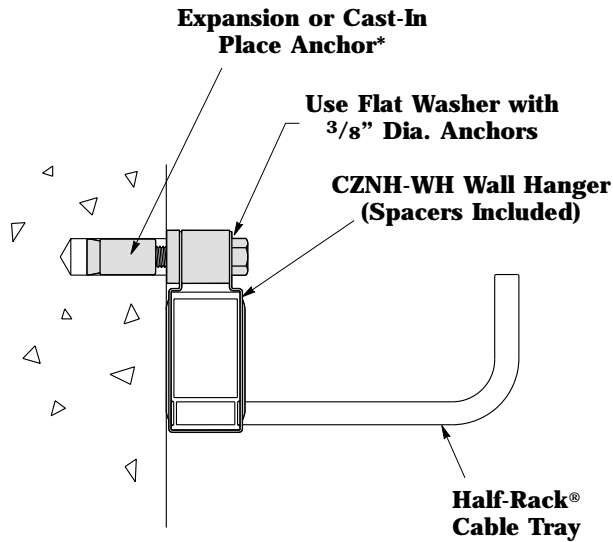

Figure 9

Maximum Support Spacing

	Total Cable Loading (lbs/ft)	Thread Diameter					
		Wedge Anchor*		Drop-In Anchor*		Cast-In Place Anchor*	
		3/8"	1/2"	3/8"	1/2"	3/8"	1/2"
6" Max. Tray Width	0 - 10	4'-0"	4'-0"	4'-0"	4'-0"	4'-0"	4'-0"
	10.01 - 25	4'-0"	4'-0"	4'-0"	4'-0"	4'-0"	4'-0"
	25.01 - 50	4'-0"	4'-0"	4'-0"	4'-0"	4'-0"	4'-0"
12" Max. Tray Width	0 - 10	4'-0"	4'-0"	4'-0"	4'-0"	4'-0"	4'-0"
	10.01 - 25	4'-0"	4'-0"	4'-0"	4'-0"	4'-0"	4'-0"
	25.01 - 50	4'-0"	4'-0"	4'-0"	4'-0"	4'-0"	4'-0"

*See anchor notes on pages 21-22.

Table 6

Note: This mounting detail serves as a vertical support, and meets all seismic bracing requirements.

CZNH-WH Wall Hanger: In Hollow CMU Wall

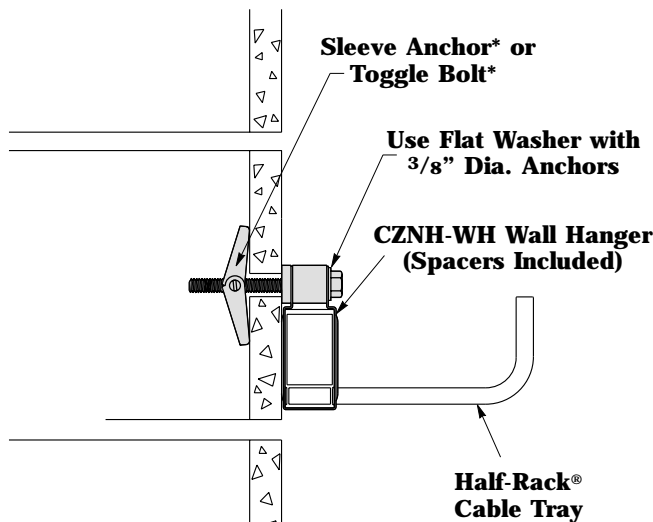

Figure 10

Maximum Support Spacing

	Total Cable Loading (lbs./ft.)	Toggle Bolt*	Sleeve Anchor*	
		Diameter	Diameter	Diameter
		3/8"	3/8"	1/2"
6" Max. Tray Width	0-10	4'-0"	4'-0"	4'-0"
	10.01-25	3'-7"	4'-0"	4'-0"
	25.01-50	1'-9"	3'-0"	3'-11"
12" Max. Tray Width	0-10	4'-0"	4'-0"	4'-0"
	10.01-25	2'-4"	3'-10"	4'-0"
	25.01-50	1'-2"	1'-11"	2'-7"

*See anchor notes on pages 21-22.

Table 7

Note: This mounting detail serves as a vertical support, and meets all seismic bracing requirements.

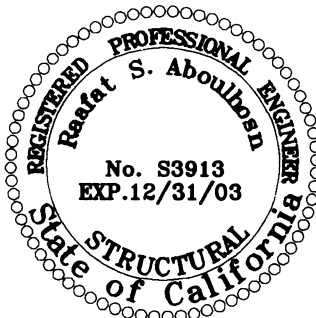

PENDING OSHPD APPROVAL

Cooper B-Line, Inc.

509 West Monroe Street
Highland, Illinois 62249

Phone : 618-654-2184
Fax : 618-654-1917



Raafat S. Aboulhoss

Structural Engineer

S 3913

Page No.

14

Date:

10 - 9 - 97

Sheet Number:

___ of ___

HALF-RACK® MOUNTING DETAILS

Drill Through Method: In Concrete Slab

Maximum Support Spacing

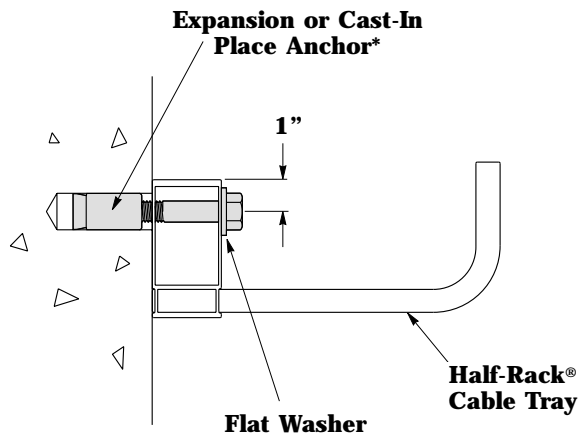

Figure 11

	Total Cable Loading (lbs/ft)	Thread Diameter					
		Wedge Anchor*		Drop-In Anchor*		Cast-In Place Anchor*	
		3/8"	1/2"	3/8"	1/2"	3/8"	1/2"
6" Max. Tray Width	0 - 10	4'-0"	4'-0"	4'-0"	4'-0"	4'-0"	4'-0"
	10.01 - 25	4'-0"	4'-0"	4'-0"	4'-0"	4'-0"	4'-0"
	25.01 - 50	3'-10"	4'-0"	3'-6"	4'-0"	3'-6"	4'-0"
12" Max. Tray Width	0 - 10	4'-0"	4'-0"	4'-0"	4'-0"	4'-0"	4'-0"
	10.01 - 25	4'-0"	4'-0"	4'-0"	4'-0"	4'-0"	4'-0"
	25.01 - 50	2'-6"	4'-0"	2'-3"	3'-4"	2'-3"	4'-0"

*See anchor notes on pages 21-22.

Table 8

Note: This mounting detail serves as a vertical support, and meets all seismic bracing requirements.

B594 Clevis U-Bracket: In Concrete Slab

Maximum Support Spacing

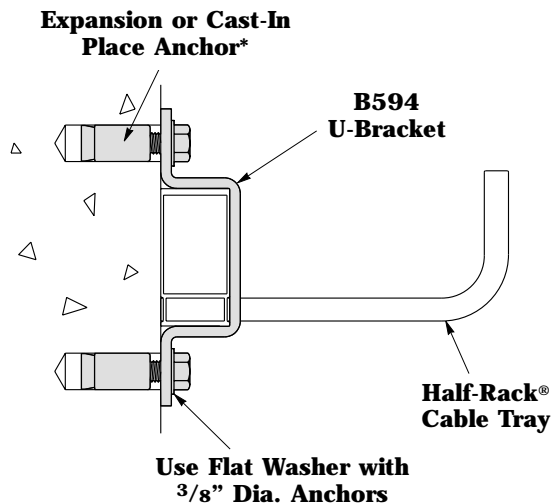

Figure 12

	Total Cable Loading (lbs/ft)	Thread Diameter					
		Wedge Anchor*		Drop-In Anchor*		Cast-In Place Anchor*	
		3/8"	1/2"	3/8"	1/2"	3/8"	1/2"
6" Max. Tray Width	0 - 10	4'-0"	4'-0"	4'-0"	4'-0"	4'-0"	4'-0"
	10.01 - 25	4'-0"	4'-0"	4'-0"	4'-0"	4'-0"	4'-0"
	25.01 - 50	4'-0"	4'-0"	4'-0"	4'-0"	4'-0"	4'-0"
12" Max. Tray Width	0 - 10	4'-0"	4'-0"	4'-0"	4'-0"	4'-0"	4'-0"
	10.01 - 25	4'-0"	4'-0"	4'-0"	4'-0"	4'-0"	4'-0"
	25.01 - 50	4'-0"	4'-0"	4'-0"	4'-0"	4'-0"	4'-0"

*See anchor notes on pages 21-22.

Table 9

Note: This mounting detail serves as a vertical support, and meets all seismic bracing requirements.

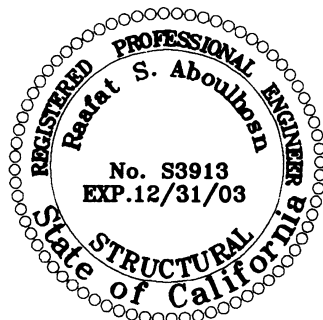

PENDING OSHPD APPROVAL

Cooper B-Line, Inc.

509 West Monroe Street
Highland, Illinois 62249

Phone : 618-654-2184
Fax : 618-654-1917

B-Line

Raafat S. Aboulhosen

Structural Engineer

S 3913

Page No.

15

Date:

10 - 9 - 97

Sheet Number:

___ of ___

HALF-RACK® MOUNTING DETAILS

B594 Clevis U-Bracket: In Wood Stud Wall

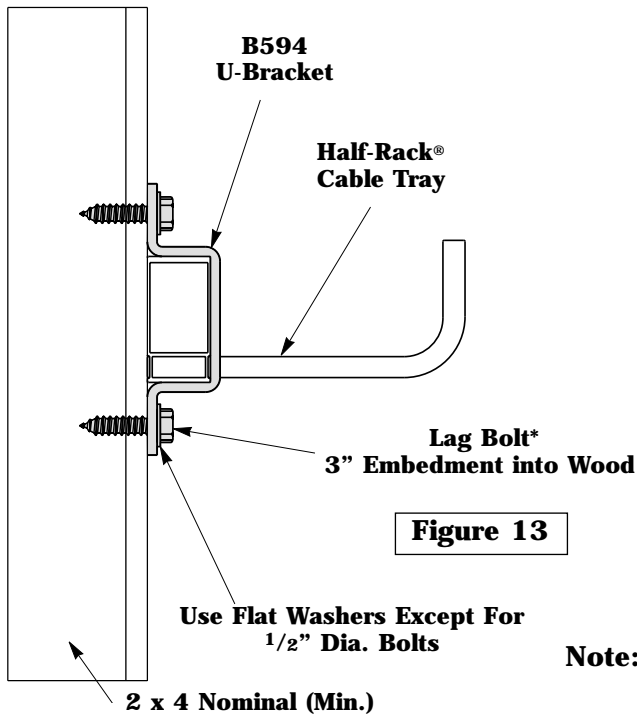

Figure 13

Maximum Support Spacing

	Total Cable Loading (lbs/ft)	Lag Bolt* Size		
		1/4"	3/8"	1/2"
6" Max. Tray Width	0 - 10	48"	48"	48"
	10.01 - 25	48"	48"	48"
	25.01 - 50	24"	32"	48"
12" Max. Tray Width	0 - 10	48"	48"	48"
	10.01 - 25	32"	48"	48"
	25.01 - 50	16"	24"	32"

*See anchor notes on pages 21-22.

Table 10

Note: This mounting detail serves as a vertical support, and meets all seismic bracing requirements.

CZNB-U10 U-Bracket: In Drywall & Metal Stud Wall

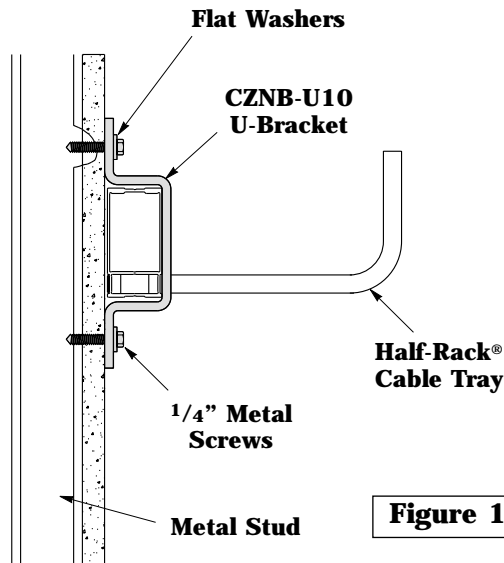

Figure 14

Maximum Support Spacing

	Total Cable Loading (lbs/ft)	Sheet Metal Thickness			
		20 Ga. (.036)	18 Ga. (.046)	16 Ga. (.063)	14 Ga. (.075)
6" Max. Tray Width	0 - 10	48"	48"	48"	48"
	10.01 - 25	24"	32"	32"	48"
12" Max. Tray Width	0 - 10	32"	48"	48"	48"
	10.01 - 25	16"	16"	24"	32"

Table 11

Note: This mounting detail serves as a vertical support, and meets all seismic bracing requirements.

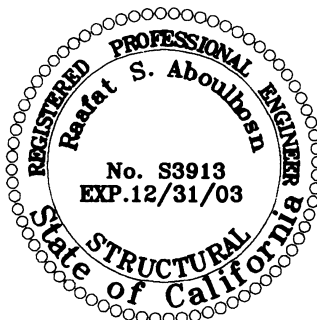

PENDING OSHPD APPROVAL

Cooper B-Line, Inc.

509 West Monroe Street
Highland, Illinois 62249

Phone : 618-654-2184
Fax : 618-654-1917

B-Line

Raafat S. Aboulhosen

Structural Engineer

S 3913

Page No.

16

Date:

10 - 9 - 97

Sheet Number:

___ of ___

MULTI-TIER HALF-RACK® MOUNTING DETAILS

CZNH-WM Wall Hanger: In Concrete Slab

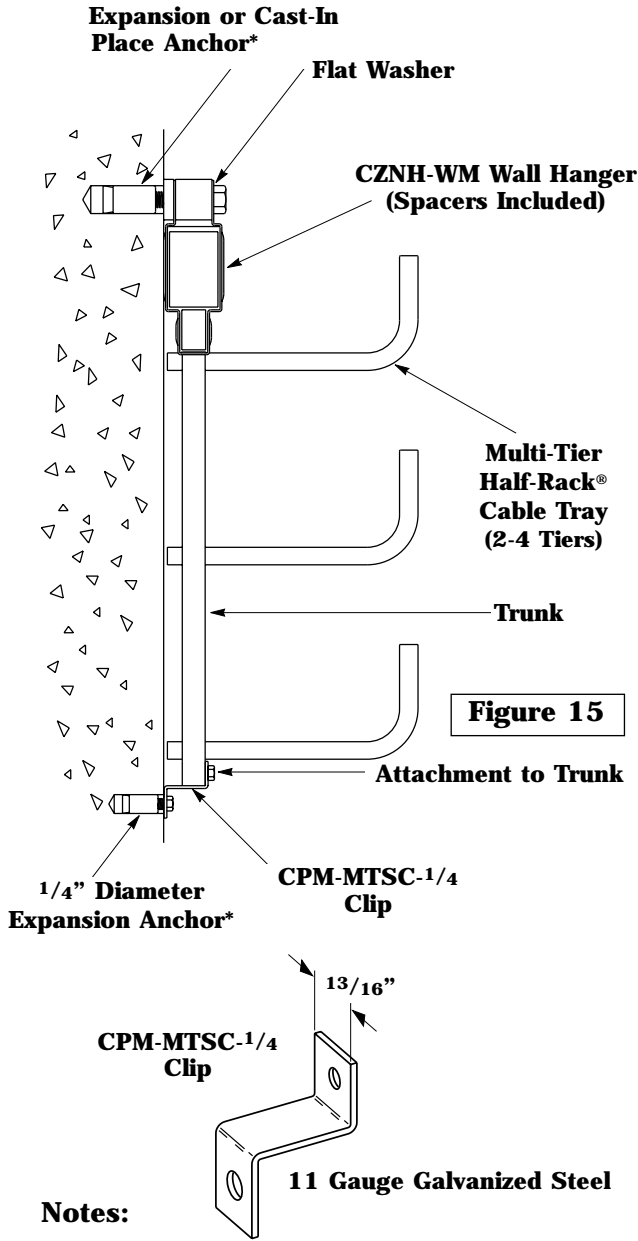

Figure 15

Maximum Support Spacing 2 Tiered Cable Tray Systems

	Loading Per Tier (lbs/ft)	Thread Diameter					
		Wedge Anchor*		Drop-In Anchor*		Cast-In Place Anchor*	
		1/4"	3/8"	1/4"	3/8"	1/4"	3/8"
6" Max. Tray Width	0 - 10	4'-0"	4'-0"	4'-0"	4'-0"	4'-0"	4'-0"
	10.01 - 25	4'-0"	4'-0"	4'-0"	4'-0"	4'-0"	4'-0"
	25.01 - 50	3'-6"	4'-0"	3'-0"	4'-0"	3'-4"	4'-0"
12" Max. Tray Width	0 - 10	4'-0"	4'-0"	4'-0"	4'-0"	4'-0"	4'-0"
	10.01 - 25	4'-0"	4'-0"	4'-0"	4'-0"	4'-0"	4'-0"
	25.01 - 50	2'-6"	4'-0"	2'-3"	4'-0"	2'-6"	4'-0"

*See anchor notes on pages 21-22.

Table 12

Maximum Support Spacing 3 or 4 Tiered Cable Tray Systems

	Loading Per Tier (lbs/ft)	Thread Diameter					
		Wedge Anchor*		Drop-In Anchor*		Cast-In Place Anchor*	
		1/4"	3/8"	1/4"	3/8"	1/4"	3/8"
6" Max. Tray Width	0 - 10	4'-0"	4'-0"	4'-0"	4'-0"	4'-0"	4'-0"
	10.01 - 25	4'-0"	4'-0"	3'-11"	4'-0"	4'-0"	4'-0"
	25.01 - 50**	2'-1"	4'-0"	2'-0"	4'-0"	2'-1"	4'-0"
12" Max. Tray Width	0 - 10	4'-0"	4'-0"	4'-0"	4'-0"	4'-0"	4'-0"
	10.01 - 25	3'-7"	4'-0"	3'-3"	4'-0"	3'-6"	4'-0"
	25.01 - 50**	1'-9"	3'-9"	1'-6"	3'-4"	1'-9"	4'-0"

*See anchor notes on pages 21-22.

** 12" maximum rung spacing.

Table 13

Notes:

- 1). This mounting detail serves as a vertical support, and meets all seismic bracing requirements.
- 2). 1 CPM-MTSC-1/4 Clip must be attached to the trunk nearest each cable tray support location using a 1/4" diameter x 1/2" long self-tapping metal screw (included).
- 3). The CPM-MTSC-1/4 Clip must be attached to the wall using a 1/4" diameter expansion anchor.*

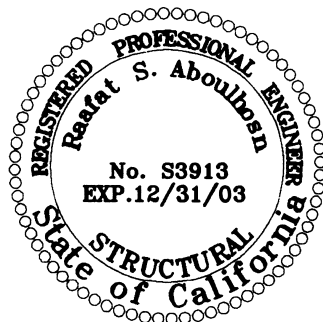

PENDING OSHPD APPROVAL

Cooper B-Line, Inc.

509 West Monroe Street
Highland, Illinois 62249

Phone :618-654-2184
Fax : 618-654-1917

B-Line

Raafat S. Aboulhosen

Structural Engineer

S 3913

Page No.

Date:

Sheet Number:

17

10 - 9 - 97

___ of ___

MULTI-TIER HALF-RACK® MOUNTING DETAILS

CZNH-WM Wall Hanger: In Hollow CMU Wall

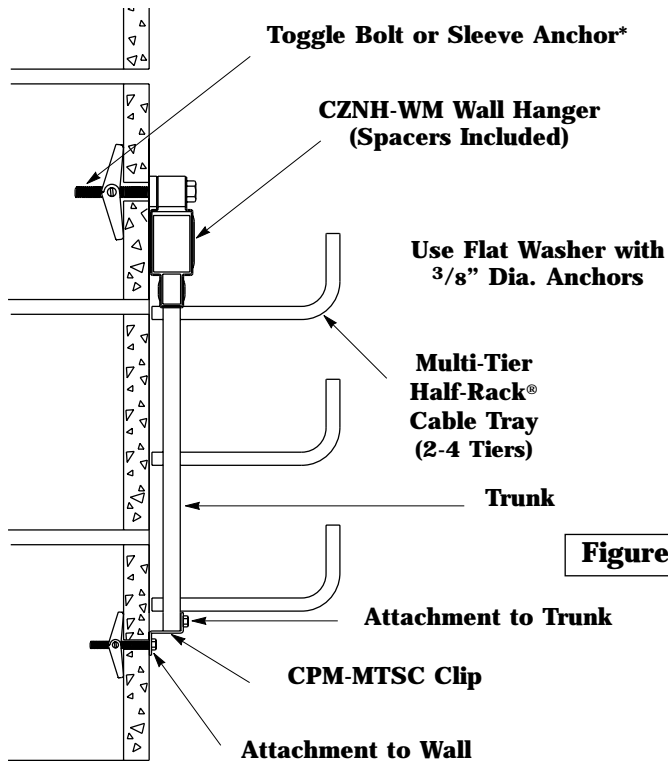
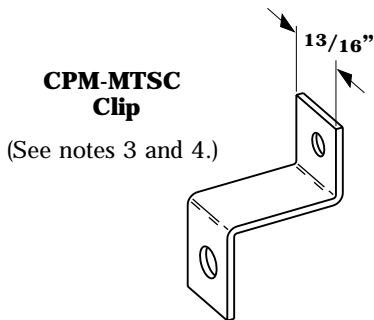

Figure 16



11 Gauge Galvanized Steel

Notes:

- 1). This mounting detail serves as a vertical support, and meets all seismic bracing requirements.
- 2). 1 CPM-MTSC Clip must be attached to the trunk nearest each cable tray support location using a 1/4" diameter x 1/2" long self-tapping metal screw (included).
- 3). The CPM-MTSC Clip must be attached to the wall using a 1/4" diameter sleeve anchor* or a 3/8" diameter toggle bolt*.
- 4). Use CPM-MTSC-1/4 for 1/4" diameter hardware, and CPM-MTSC-3/8 for 3/8" diameter hardware.

Maximum Support Spacing 2 Tiered Cable Tray Systems

	Loading Per Tier (lbs/ft)	Toggle Bolt* Diameter	Sleeve Anchor* Diameter	
			3/8"	1/2"
6" Max. Tray Width	0 - 10	4'-0"	4'-0"	4'-0"
	10.01 - 25	4'-0"	4'-0"	4'-0"
	25.01 - 50	2'-0"	3'-4"	4'-0"
12" Max. Tray Width	0 - 10	4'-0"	4'-0"	4'-0"
	10.01 - 25	3'-0"	4'-0"	4'-0"
	25.01 - 50	1'-6"	2'-4"	3'-3"

*See anchor notes on pages 21-22.

Table 14

Maximum Support Spacing 3 or 4 Tiered Cable Tray Systems

	Loading Per Tier (lbs/ft)	Toggle Bolt* Diameter	Sleeve Anchor* Diameter	
			3/8"	1/2"
6" Max. Tray Width	0 - 10	4'-0"	4'-0"	4'-0"
	10.01 - 25	2'-8"	4'-0"	4'-0"
	25.01 - 50**	1'-4"	2'-3"	2'-10"
12" Max. Tray Width	0 - 10	4'-0"	4'-0"	4'-0"
	10.01 - 25	2'-2"	3'-7"	4'-0"
	25.01 - 50**	1'-1"	1'-9"	2'-3"

*See anchor notes on pages 21-22.

** 12" maximum rung spacing.

Table 15

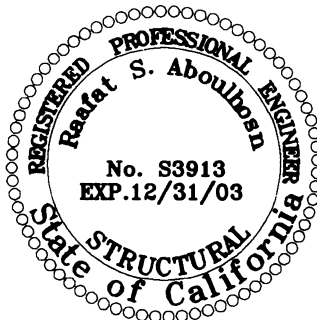

PENDING OSHPD APPROVAL

Cooper B-Line, Inc.

509 West Monroe Street
Highland, Illinois 62249

Phone :618-654-2184
Fax : 618-654-1917

B-Line

Raafat S. Aboulhoss

Structural Engineer

S 3913

Page No.

Date:

Sheet Number:

18

10 - 9 - 97

___ of ___

MULTI-TIER HALF-RACK® MOUNTING DETAILS

CZNH-WM Wall Hanger: In Drywall & Metal Stud Wall

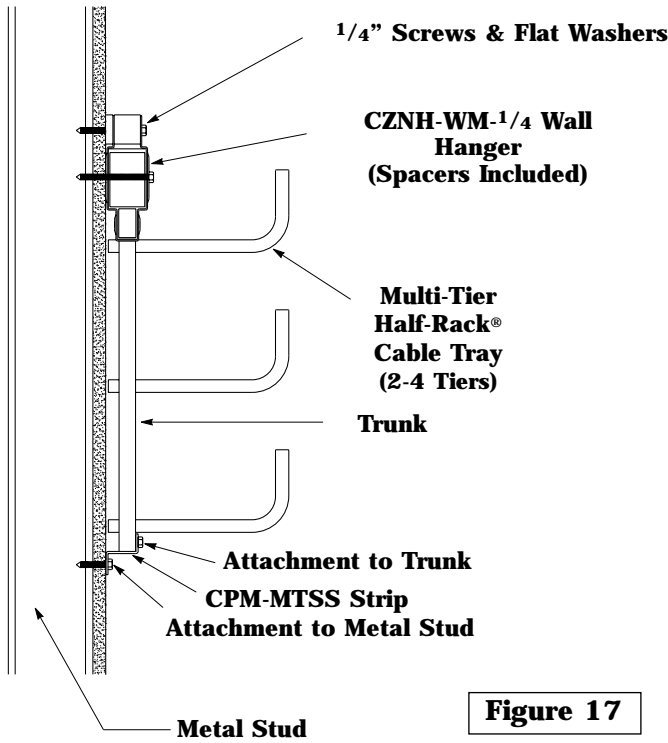
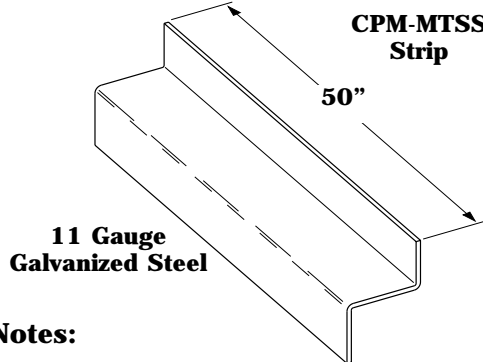

Figure 17



Notes:

- 1). This mounting detail serves as a vertical support, and meets all seismic bracing requirements.
- 2). A CPM-MTSS Strip must be run continuously below the bottom tier as shown. Discontinuous gaps between CPM-MTSS Strips are permitted between studs.
- 3). The CPM-MTSS Strip must be attached to the trunk of the cable tray at a spacing not to exceed the maximum support spacing given in Table 16 or 17; using 1/4" diameter x 1/2" long self-tapping metal screws (4 screws included with each CPM-MTSS Strip).
- 4). The CPM-MTSS Strip must be attached to the wall at a minimum of every 2'-0" using 1/4" diameter self-tapping metal screws (not included) fastened into the metal studs.

Maximum Support Spacing 2 Tiered Cable Tray Systems

	Loading Per Tier (lbs/ft)	Sheet Metal Thickness			
		20 Ga. (.036)	18 Ga. (.046)	16 Ga. (.063)	14 Ga. (.075)
6" Max. Tray Width	0 - 10	48"	48"	48"	48"
	10.01 - 25	36"	48"	48"	48"
12" Max. Tray Width	0 - 10	48"	48"	48"	48"
	10.01 - 25	32"	42"	48"	48"

Table 16

Maximum Support Spacing 3 or 4 Tiered Cable Tray Systems

	Loading Per Tier (lbs/ft)	Sheet Metal Thickness			
		20 Ga. (.036)	18 Ga. (.046)	16 Ga. (.063)	14 Ga. (.075)
6" Max. Tray Width	0 - 10	48"	48"	48"	48"
	10.01 - 25	32"	32"	48"	48"
12" Max. Tray Width	0 - 10	48"	48"	48"	48"
	10.01 - 25	24"	32"	32"	48"

Table 17

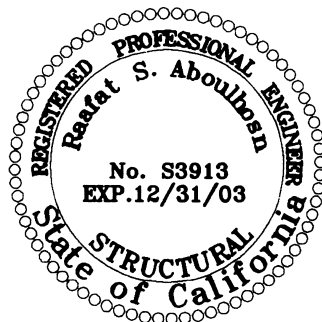

PENDING OSHPD APPROVAL

Cooper B-Line, Inc.

509 West Monroe Street
Highland, Illinois 62249

Phone :618-654-2184
Fax : 618-654-1917



Raafat S. Aboulhosen

Structural Engineer

S 3913

Page No.

Date:

Sheet Number:

19

10 - 9 - 97

___ of ___

MULTI-TIER HALF-RACK® MOUNTING DETAILS

CZNH-WM Wall Hanger: In Wood Stud Wall

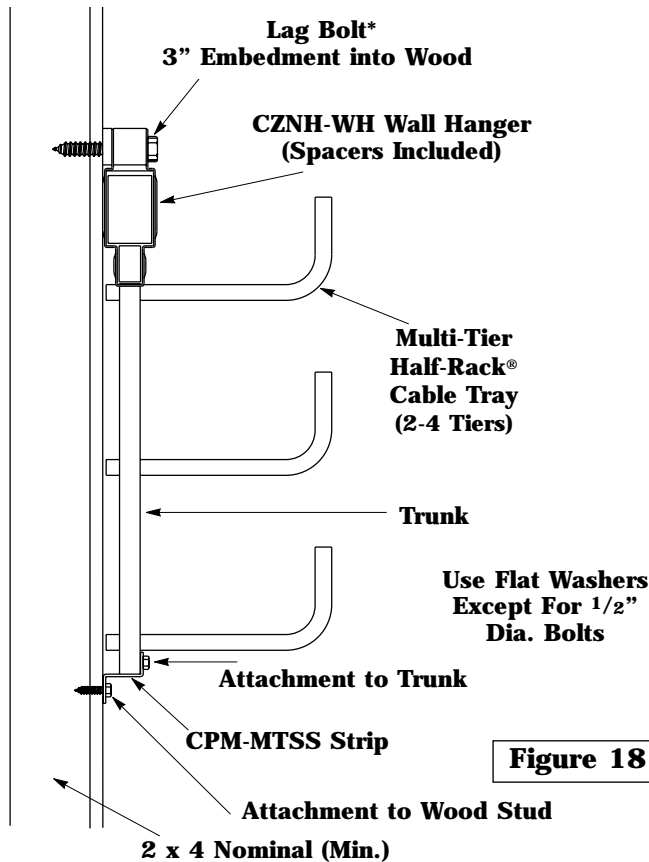
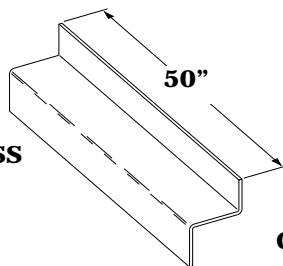

Figure 18

CPM-MTSS Strip



11 Gauge Galvanized Steel

Notes:

- 1). This mounting detail serves as a vertical support, and meets all seismic bracing requirements.
- 2). A CPM-MTSS Strip must be run continuously below the bottom tier as shown. Discontinuous gaps between CPM-MTSS Strips are permitted between studs.
- 3). The CPM-MTSS Strip must be attached to the trunk of the cable tray at a spacing not to exceed the maximum support spacing given in Table 18 or 19; using 1/4" diameter x 1/2" long self-tapping metal screws (4 screws included with each CPM-MTSS Strip).
- 4). The CPM-MTSS Strip must be attached to the wall at a minimum of every 2'-0" using 1/4" diameter lag bolts with a minimum embedment of 2" into the wood studs.

Maximum Support Spacing 2 Tiered Cable Tray Systems

	Loading Per Tier (lbs/ft)	Lag Bolt* Size		
		1/4"	3/8"	1/2"
6" Max. Tray Width	0 - 10	48"	48"	48"
	10.01 - 25	48"	48"	48"
	25.01 - 50	36"	48"	48"
12" Max. Tray Width	0 - 10	48"	48"	48"
	10.01 - 25	36"	48"	48"
	25.01 - 50	16"	32"	42"

*See anchor notes on pages 21-22.

Table 18

Maximum Support Spacing 3 or 4 Tiered Cable Tray Systems

	Loading Per Tier (lbs/ft)	Lag Bolt* Size		
		1/4"	3/8"	1/2"
6" Max. Tray Width	0 - 10	48"	48"	48"
	10.01 - 25	42"	48"	48"
	25.01 - 50**	16"	32"	36"
12" Max. Tray Width	0 - 10	48"	48"	48"
	10.01 - 25	36"	48"	48"
	25.01 - 50**	16"	24"	36"

*See anchor notes on pages 21-22.

**12" maximum rung spacing.

Table 19

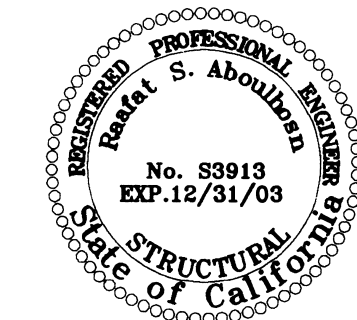

PENDING OSHPD APPROVAL

Cooper B-Line, Inc.

509 West Monroe Street
Highland, Illinois 62249

Phone : 618-654-2184
Fax : 618-654-1917

B-Line

Raafat S. Aboulhoss

Structural Engineer

S 3913

Page No.

20

Date:

10 - 9 - 97

Sheet Number:

___ of ___

ANCHORING NOTES

Wedge Anchors

Notes:

- 1). Wedge anchors shall be Hilti Kwik Bolt-II, ICBO Report Number 4627. Carbon steel or stainless steel anchors can be used. Other anchors may be used in place of Hilti Kwik Bolt-II provided they have an ICBO rating of equal or greater loading values. Install anchors in accordance with manufacturer's recommendations.
- 2). Minimum embedment depth is as follows:

Anchor Diameter	Min. Embedment Depth
1/4"	2"
3/8"	2 1/2"
1/2"	3 1/2"
- 3). When the slab thickness is less than the minimum embedment plus 1 inch; use through bolts, washers, and nuts.
- 4). 50% of the anchors shall be proof tested to 80% of twice the allowable load in tension. If any anchor fails, the immediate adjacent anchors must also be tested.
- 5). The anchors shall be installed in 3000 psi normal weight concrete. Consult the engineer of record for lightweight concrete or where the concrete has a strength less than 3000 psi.
- 6). When installing drill-in anchors in existing non-prestressed reinforced concrete, use caution to avoid cutting or damaging existing reinforcing bars. When installing them into existing prestressed concrete (pre- or post-tensioned), locate the tendons by using a non-destructive method prior to installation. Maintain a minimum clearance of one inch between the reinforcement and the anchor.

Sleeve Anchors

Notes:

- 1). Sleeve anchors shall be Hilti Hex Head Sleeve Anchors. Carbon steel or stainless steel anchors can be used. Other anchors may be used in place of Hilti provided they have a rating of equal or greater loading values. Install anchors in accordance with manufacturers recommendations.
- 2). Minimum embedment depth is as follows:

Anchor Diameter	Min. Embedment Depth
3/8"	1 1/4"
1/2"	1 1/2"



PENDING OSHPD APPROVAL

Cooper B-Line, Inc.

509 West Monroe Street
Highland, Illinois 62249

Phone :618-654-2184
Fax : 618-654-1917

B-Line

Raafat S. Aboulhosen

Structural Engineer

S 3913

Page No.

21

Date:

10 - 9 - 97

Sheet Number:

___ of ___

ANCHORING NOTES

Drop-in (Shell Type) Anchors

- 1). Shell type anchors shall be Hilti Drop-In, ICBO Report Number 2895. Other anchors may be used in place of Hilti Drop-In provided they have an ICBO rating of equal or greater loading values. Install anchors in accordance with manufacturers recommendations.
- 2). Minimum embedment depth is as follows:

Anchor Diameter	Min. Embedment Depth
1/4"	1"
3/8"	1 ⁹ / ₁₆ "
1/2"	2"
- 3). When the slab thickness is less than the minimum embedment plus 1 inch; use through bolts, washers, and nuts.
- 4). 50% of the anchors shall be proof tested to 80% of twice the allowable load in tension. If any anchor fails, the immediate adjacent anchors must also be tested.
- 5). The anchors shall be installed in 3000 psi normal weight concrete. Consult the engineer of record for lightweight concrete or where the concrete has a strength less than 3000 psi.
- 6). When installing drill-in anchors in existing non-prestressed reinforced concrete, use caution to avoid cutting or damaging existing reinforcing bars. When installing them into existing prestressed concrete (pre- or post-tensioned), locate the tendons by using a non-destructive method prior to installation. Maintain a minimum clearance of one inch between the reinforcement and the anchor. Do not use drop-in anchors in the tension zone of concrete slabs.

Cast-In-Place Anchors

- 1). Cast-in-place anchors shall meet the requirements as set forth in the California Building Code.

Lag Bolts

- 1). Lag bolts of all diameters shall have 3" embedment into wood studs, unless noted otherwise.

Toggle Bolts

- 1). Toggle bolts are to be used for hollow CMU construction, and consist of a toggle head and a machine screw. Toggle bolts shall be B-Line ATB series. Other anchors suitable for hollow CMU construction may be used provided they have a rating of equal or greater load values. Install anchors in accordance with manufacturers recommendations.



PENDING OSHPD APPROVAL

Cooper B-Line, Inc.

509 West Monroe Street
Highland, Illinois 62249

Phone :618-654-2184
Fax : 618-654-1917

B-Line

Raafat S. Aboulhosen

Structural Engineer

S 3913

Page No.

22

Date:

10 - 9 - 97

Sheet Number:

___ of ___

APPENDIX - SEISMIC MAP & METRIC CONVERSION CHARTS

SEISMIC MAP

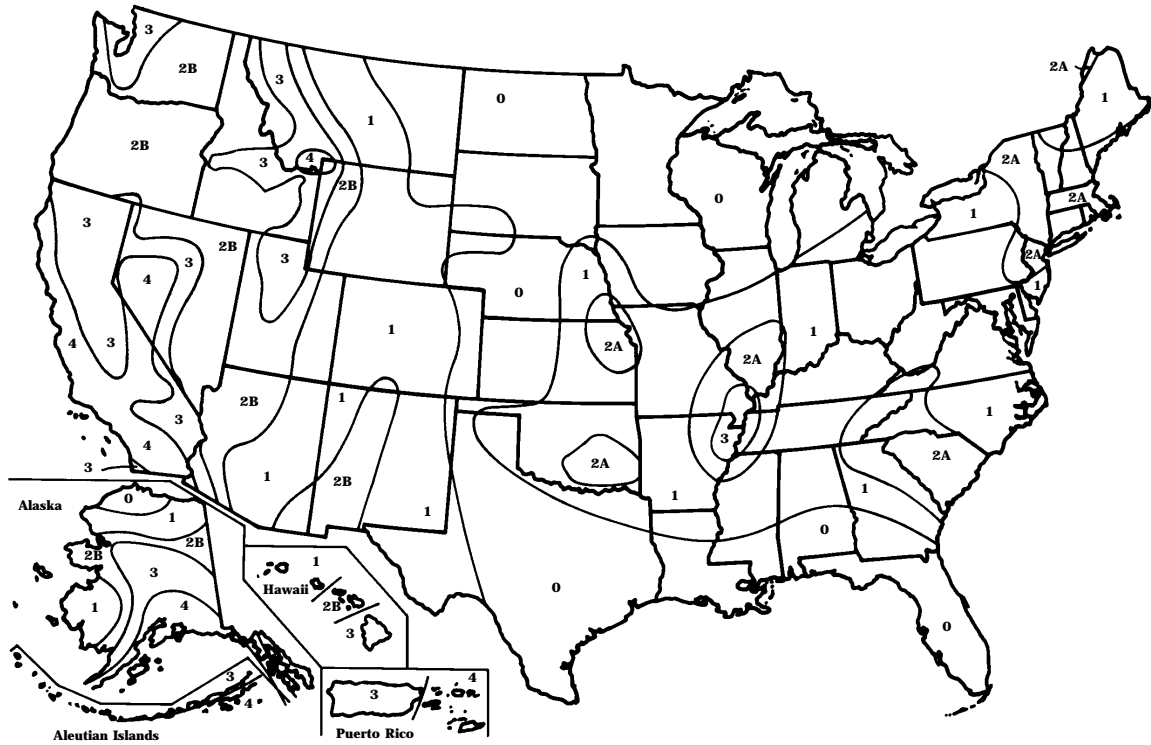

This guideline is based on the California Code of Regulations Title 24, Part 2 requirements for hospitals and essential facilities in seismic zone 4. Essential facilities are those structures which are necessary for emergency post-earthquake operations. See CCR, Title 24, Part 2, Table 23-K for a list of types of essential facilities.

The formula for lateral seismic force from CCR, Title 24, Section 12-10 and Table 23-P; $FP = ZICpWp = 0.45Wp$ (seismic zone 4).

Any modifications of this guideline for less stringent seismic zones, shall be made in accordance to the most recent uniform building code and by a qualified registered engineer.

METRIC CONVERSION CHART

To Convert From	To	Multiply By	Metric Symbols
inch (in)	millimeter (mm)	$2.540000 \times 10^{+1}$	cm = centimeter
inch (in)	centimeter (cm)	2.540000	kg = kilogram
inch (in)	meter (m)	2.540000×10^{-2}	kN = kilonewton
foot (ft)	meter (m)	3.048000×10^{-1}	m = meter
inch ² (in ²) *	centimeter (cm ²)	6.451600	mm = millimeter
inch ³ (in ³) **	centimeter (cm ³)	$1.638706 \times 10^{+1}$	N = newton
inch ⁴ (in ⁴) ***	centimeter (cm ⁴)	$4.162314 \times 10^{+1}$	
pound (lb)	kilogram (kg)	4.535924×10^{-1}	* Area of Section
pound/foot (lb/ft)	kilogram/meter (kg/m)	1.488164	** Section Modulus (S)
pounds-force (lbf)	kilonewton (kN)	0.004448	*** Moment of Inertia
pounds-force (lbf)	newton (N)	4.448222	

Cable Tray

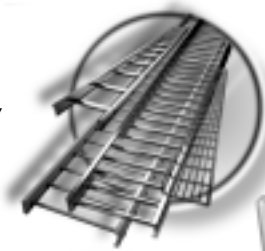

Bolted Framing



Spring Steel Fasteners



Electrical Enclosures



Electronic Enclosures



Cable Runway & Relay Racks



Customer Service

Electrical/Mechanical

Phone: 618-654-2184
Fax: 618-654-1917
Address: Cooper B-Line
509 West Monroe St.
Highland, IL 62249

Telecom

303-375-8000
303-375-8015
Cooper B-Line
21000 East 32nd Parkway
Aurora, CO 80011

www.cooperb-line.com

