

Parts Catalog

June 2007



Model No.	Page	Model No.	Page
00-R	13	150,150L, 150LS	33
00-RB	15	151 & 151P thru 156 & 156P	34
1	8	161	19
1-A	30	202	30
2	8, 9, 12	205, 205-P	36
2-A	30	206	24
2-P	8	226	25
2-S	12	228	28
3	12	246	26
3-S	31	248	27
4	11	254	12
4-S	31	266	29
5, 5-P	8	276	29
6	2	310, 310M	59
6-S	31	312, 312M	59
8	2	314M	59
8R111S	63	315M	59
10	1, 2, 37	316M	59
10 Rap Wrench	2	318M	59
11-R	14	342	7
12	1, 2, 6	345/345M	55
12-R	13	358	58
12-R IMC	13	368	58
14	1, 2, 4	375	55
15	6, 37	377	57
15-SI	38	378	58
16	4	402	11
17	6	403	59
18	1, 2, 4	404	59
20	37	405	59
21, 22, 23	43	406, 406M	59
24	2, 4	408, 408M	59
25	6, 43	410M	59
27	43	412M	59
30	37	418	10, 11
30-A	15	424S/424 CI/424DI	30
31-A, 31-B	15	425	47
33-B, 35-B	15	450	48
36	2	460	49
37-B	15	454-W, 455, 454-J	55
39	52	458, 458MM	57
40-A	46	458R	56
42-A	31	461 thru 464	53
44-S	31	466C, 466HWS, 466S	30
46	20	468C, 468HWS, 468S	30
48	2	472C, 472HWS, 472S	30
60	2	506, 508	60
65R-C, 65R-TC	16	560	50
87	41	640	51
92	20	810 thru 836	2
101	32	915	66-68
102	39	965	20
103, 104	32	1010 thru 1019	7
106	39	1450	65
108, 109, 109-P	40	1493	35
117	32	3215 thru 3237	8
118	33		
138	33		
141	17, 18		

RIDGID Tool Category Index

	Page
Wrenches	1-8
Oilers	9-11
Reamers	12
Pipe/Bolt Threaders	13-19
Pipe Supports	20
Pipe Stands	21-23
Soil Pipe Cutters/Assembly Tool	24-29
Pipe Cutters	30-31
Tubing Cutters/Cable Trimmer	32-41
Pipe and Tubing Cutter Wheels	42
Vises	43-54
Flaring Tools	55-57
Lever-Type/Ratchet Tube Benders	58-60
Bolt Cutters	61
Hydraulic Knockouts	62-63
Expanders	64
Pressure Test Pump	65
Roll Groovers	66-68
Tapping Tools	69-72
Die Charts	73-74
Warranty	Rear Cover

Model Numbers with "Alpha" Prefixes

Model No	Page	Model No	Page	Model No	Page
AR-99	23	E-910 thru E-924	4	RT-1000	69
BC-2A thru BC-8A	45	F-45,F-50, F-60	54	MLT3401	70 & 71
BC-210 thru BC-810	44	FT-456R	56	RT-3422	72
BC-210-P & BC-410-P	44	H-18	62	S-2	5
C-12 thru C-36	7 & 8	Model S	64	S-4A thru S-8A	5
CJ-98, CJ-99	21	PC-1375	35	S-14 thru S-42	61
D-1440	18	RJ-98, RJ-99	21	Spud Wrench	6
E-6 thru E-36	3	RJ-624	22	VJ-98, VJ-99	21
E-110	6	R200	14		

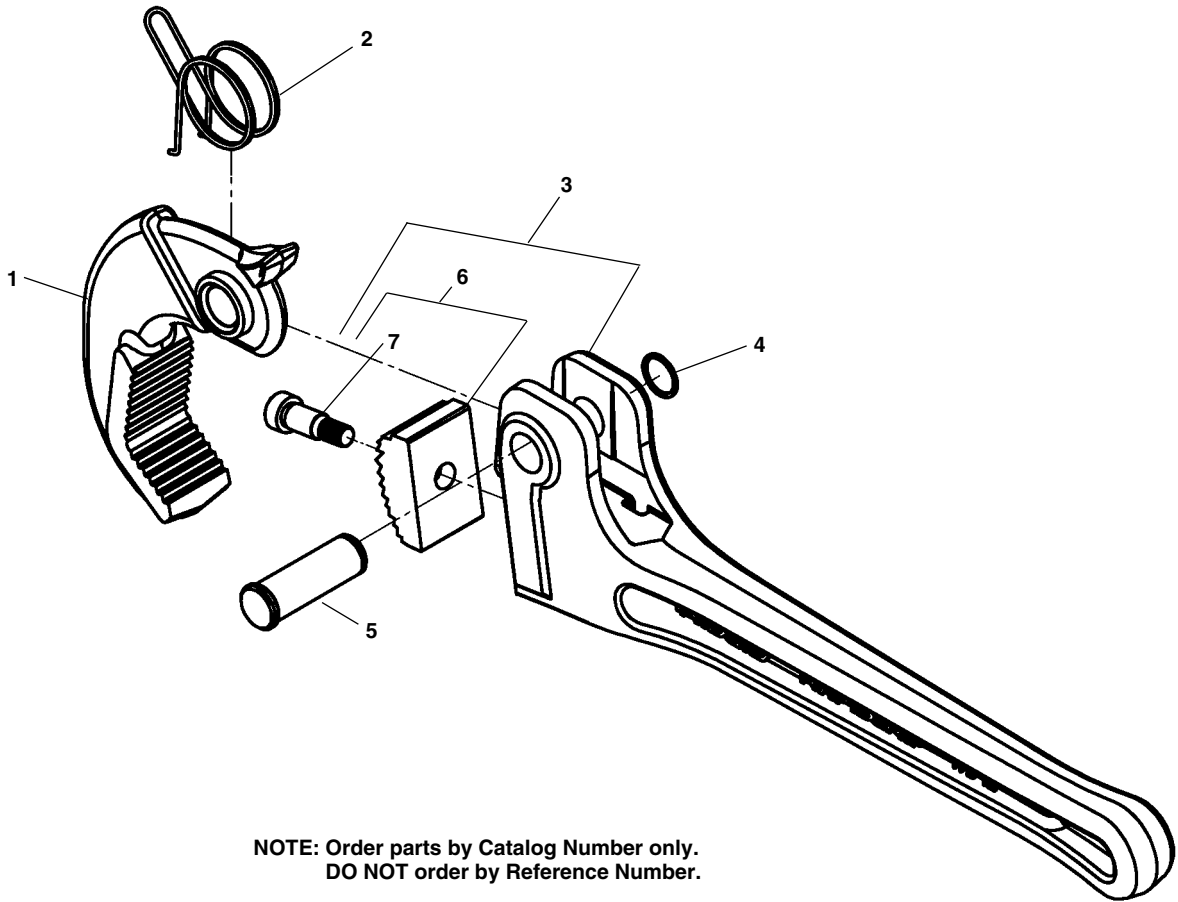

**NOTE: Order parts by Catalog Number only.
DO NOT order by Reference Number.**

Steel Wrenches

Model		10	14
Pipe Capacity		1 1/2"	2"
Ref. No.	Description	Catalog No.	Catalog No.
—	RAPIDGRIP Wrench	10348	10358
1	Hook Jaw	15183	98032
2	Torsion Spring	15188	98042
3	Handle Assembly, (Inc. Ref. 3, 6,7)	15193	15178
4	Retaining Ring (2)	15208	98052
5	Pivot Pin w/Retaining Rings	15218	98047
6	Heel Jaw (Inc. Ref. 7)	15233	98062
7	Shoulder Bolt	15243	98037

Aluminum Wrenches

Model		14	18
Pipe Capacity		2"	3"
Ref. No.	Description	Catalog No.	Catalog No.
—	RAPIDGRIP Wrench	12693	12698
1	Hook Jaw	98032	15103
2	Torsion Spring	98042	15108
3	Handle Assembly, (Inc. Ref. 3, 6,7)	18968	18973
4	Retaining Ring (2)	98052	98052
5	Pivot Pin w/Retaining Rings	98047	15168
6	Heel Jaw (Inc. Ref. 7)	98062	15173
7	Shoulder Bolt	98037	98037

Straight Pipe Wrench

Capacity: 3/4" through 8"

NOTE: Order parts by Catalog Number only. DO NOT order by Reference Number.

10 Rap Wrench

Ref. No.	Catalog No.	Description
1	32775	Handle Assembly
2	31615	Nut
3	31625	Pin
4	31610	Heel Jaw Assembly
5	31620	Spring Assembly
6	31605	Hook Jaw

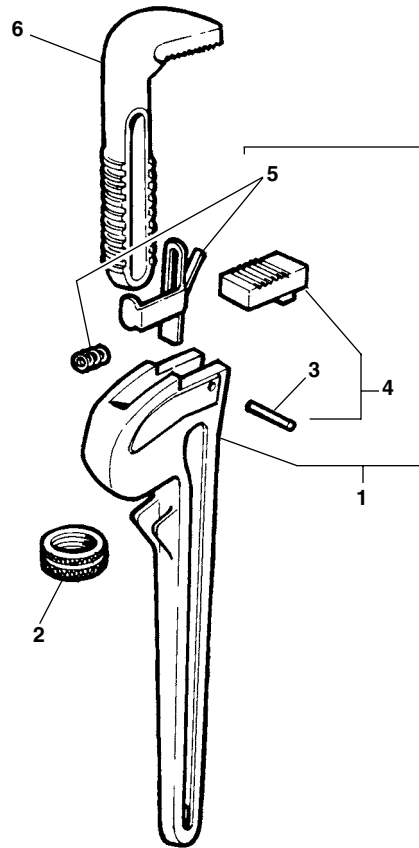

Steel Wrenches

Model Pipe Capacity	6 3/4"	8 1"	10 1 1/2"	12 2"	14 2"	18 2 1/2"	24 3"	36 5"	48 6"	60 8"
Ref. No. Description	Catalog No.	Catalog No.	Catalog No.	Catalog No.	Catalog No.	Catalog No.	Catalog No.	Catalog No.	Catalog No.	Catalog No.
1 Handle Assembly	31420	31425	31430	31435	31440	31445	31450	31455	31460	31465
2 Nut	31570	31595	31615	31645	31665	31685	31710	31735	31760	31785
3 Pin	31575	31600	31625	31650	31650	31690	31715	31740	31765	31790
4 Heel Jaw Assembly	31560	31585	31610	31635	31635	31675	31700	31725	31750	*31775
5 Spring Assembly	31565	31590	31620	31640	31660	31680	31705	31730	31755	31780
6 Hook Jaw	31555	31580	31605	31630	31655	31670	31695	31720	31745	31770

Service Note : Catalog No. 31775 Heel Jaw also used on Hook Jaw

Aluminum Wrenches

Model Pipe Capacity	810 1 1/2"	812 2"	814 2"	818 2 1/2"	824 3"	836 5"	848 6"
Ref. No. Description	Catalog No.	Catalog No.	Catalog No.	Catalog No.	Catalog No.	Catalog No.	Catalog No.
1 Handle Assembly	31510	49972	31515	31520	31525	31530	31535
2 Nut	31615	31645	31665	31685	31710	31735	31760
3 Pin	31625	31650	31650	31690	31715	31740	31765
4 Heel Jaw Assembly	31610	31635	31635	31675	31700	31725	31750
5 Spring Assembly	31620	31640	31660	31680	31705	31730	31755
6 Hook Jaw	31605	31630	31655	31670	31695	31720	31745

End Pipe Wrench

Capacity: 3/4" through 5"

NOTE: Order parts by Catalog Number only.
DO NOT order by Reference Number.

Aluminum Wrenches

Ref. No.	Model Pipe Capacity	E-910 1 1/2"	E-914 2"	E-918 2 1/2"	E-924 3"
1	Handle Assembly	93907	93912	93917	93922
2	Nut	31615	31665	31685	31710
3	Pin	95402	95407	31690	31690
4	Heel Jaw Assembly	31610	31635	31675	31700
5	Spring Assembly	31620	31660	31680	31705
6	Hook Jaw	31605	31655	31670	31695

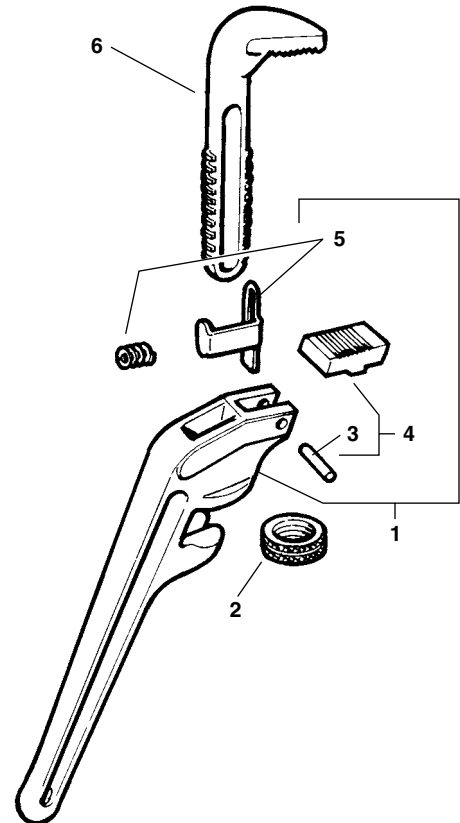

Steel Wrenches

Ref. No.	Model Pipe Capacity	E-6 3/4"	E-8 1"	E-10 1 1/2"	E-12 2"	E-14 2"	E-18 2 1/2"	E-24 3"	E-36 5"
1	Handle Assembly	31470	31475	31480	31485	31490	31495	31500	31505
2	Nut	31570	31595	31615	31645	31665	31685	31710	31735
3	Pin	31575	31600	31625	31650	31650	31690	31715	31740
4	Heel Jaw Assembly	31560	31585	31610	31635	31635	31675	31700	31725
5	Spring Assembly	31565	31590	31620	31640	31660	31680	31705	31730
6	Hook Jaw	31555	31580	31605	31630	31655	31670	31695	31720

Offset Wrench

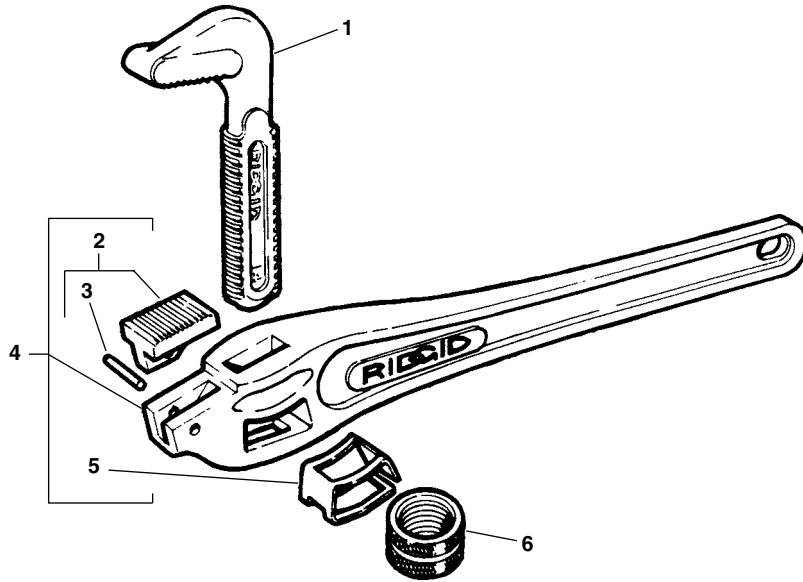

**NOTE: Order parts by Catalog Number only.
DO NOT order by Reference Number.**

Ref. No.	Description	14	18	24
		1/8"-2"	1/4"-2 1/2"	1/4"-3"
1	Hook Jaw	32490	32505	32520
2	Heel Jaw Assembly	31635	31675	31700
3	Pin	31650	31690	31715
4	H.D. Handle Assembly	92080	92085	92090
	Alum. Handle Assembly	32480	32495	32510
5	Spring	32485	32500	32515
6	Nut	31665	31685	31710

No. 16 Vertical Wrench

Capacity: 2"

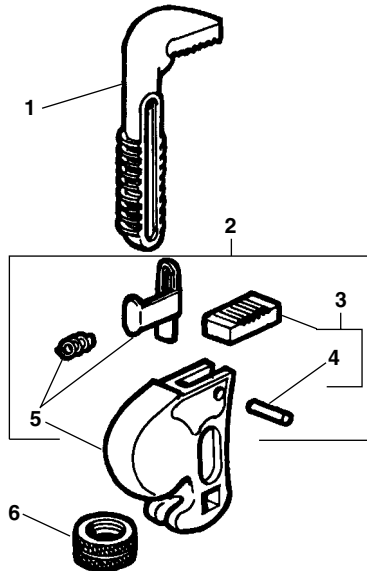

Ref. No.	Catalog No.	Description
1	31655	Hook Jaw
2	32805	Head Assembly
3	31635	Heel Jaw Assembly
4	31650	Pin
5	31660	Spring Assembly
6	31665	Nut

Compound Leverage Wrench

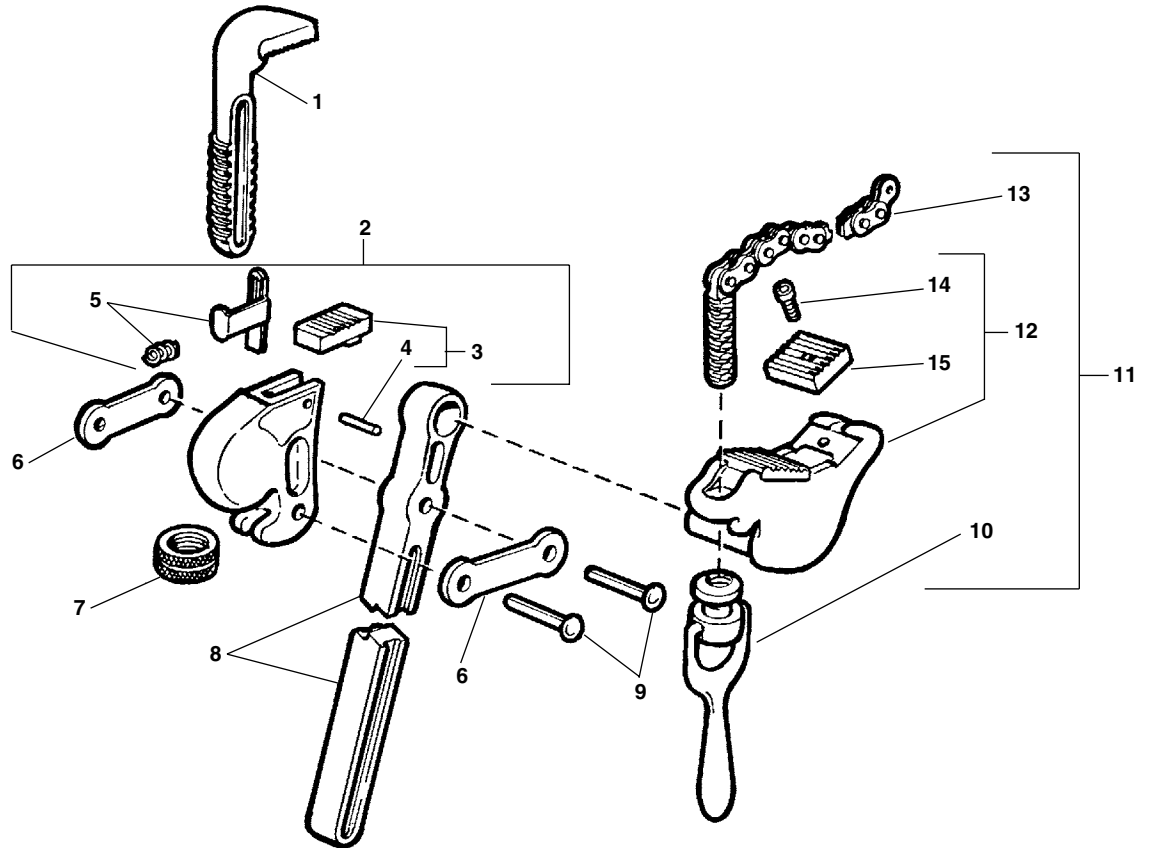

**NOTE: Order parts by Catalog Number only.
DO NOT order by Reference Number.**

Ref. No.	Description	S2	S4A	S6A	S8A
		Max. 2"	Max. 5"	Max. 6"	Max. 8"
Ref. No.	Description	Catalog No.	Catalog No.	Catalog No.	Catalog No.
1	Hook Jaw	31655	31720	31745	31770
2	Head Assembly	32105	32170	32245	32300
3	Heel Jaw Assembly	31635	31725	31750	31775
4	Pin	31650	31740	31765	31790
5	Spring Assembly	31660	31730	31755	31780
6	Side Bar (2)	23140	32210	32260	32260
7	Nut	31665	31735	31760	31785
8	Wrench Handle	32125	32195	32250	32250
9	Rivet (2)	74680	32215	32220	32220
10	Nut and Handle Assembly	32115	40765	40765	40810
11	Trunnion Assembly	32085	32150	32225	32280
	Trunnion	32090	32155	32230	32285
13	Chain Assembly	32110	32180	32180	40800
14	Screw (2)	32145	32205	32275	32270
15	Trunnion Jaw (2)	32100	32165	32240	32295

12" Spud Wrench
Capacity: 2⁵/₈"

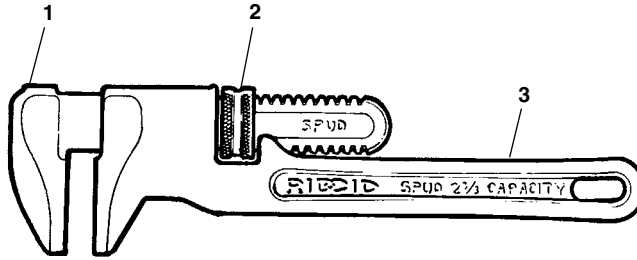

**NOTE: Order parts by Catalog Number only.
DO NOT order by Reference Number.**

Ref. No.	Catalog No.	Description
—	31400	Spud Wrench
1	32785	Jaw
2	31665	Nut
3	32780	Handle

E-110 Offset Hex Wrench
Capacity: 1¹/₂" Drain Nuts

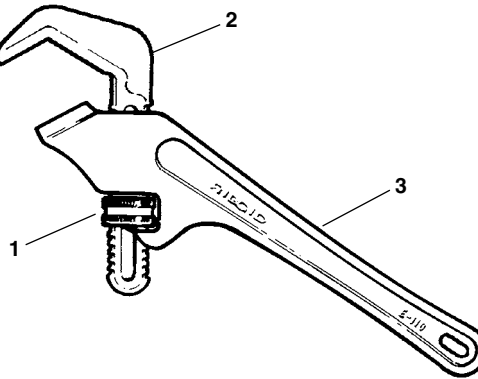

Ref. No.	Catalog No.	Description
—	31305	E-110 Offset Hex Wrench
1	31615	Nut
2	32690	Hook Jaw
3	32695	Handle

Straight Hex Wrench
Capacity: ³/₁₆" through 2"

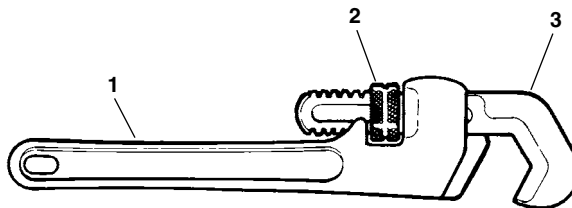

Ref. No.	Description	17	25
		⁵ / ₈ "-1 ¹ / ₄ "	1"-2"
1	Handle	Catalog No. 32650	Catalog No. 32660
2	Nut	31685	31710
3	Hook Jaw	32645	32655

Basin Wrenches

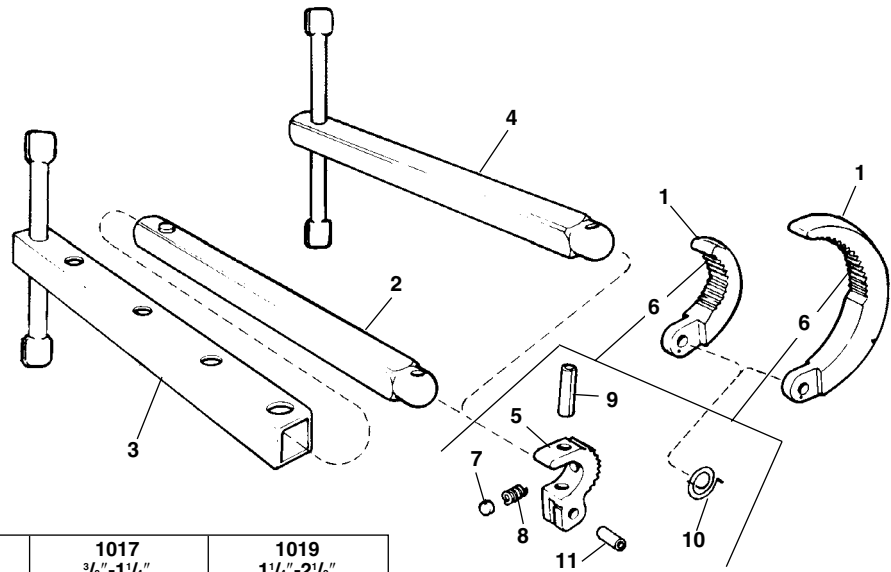

**NOTE: Order parts by Catalog Number only.
DO NOT order by Reference Number.**

	1010 3/8"-1 1/4"	1017 3/8"-1 1/4"	1019 1 1/4"-2 1/2"
Ref. No.	Catalog No.	Catalog No.	Catalog No.
— Basin Wrench	31170	31175	31180
1 Swing Jaw	32740	32740	32770
2 Slide Bar Assembly	—	32765	32765
3 Sleeve & Handle Assembly	—	32705	32720
4 Handle Assembly	32700	—	—
5 Fixed Jaw	32710	32710	32710
6 Jaw Assembly	32715	32715	32725
7 Tension Plug	32755	32755	32755
8 Coil Spring	32745	32745	32745
9 Spring Pin	32760	32760	32760
10 Spiral Spring	32730	32730	32730
11 Spring Pin	32475	32475	32475

No. 342 Internal Wrench

Capacity: 1" through 2"

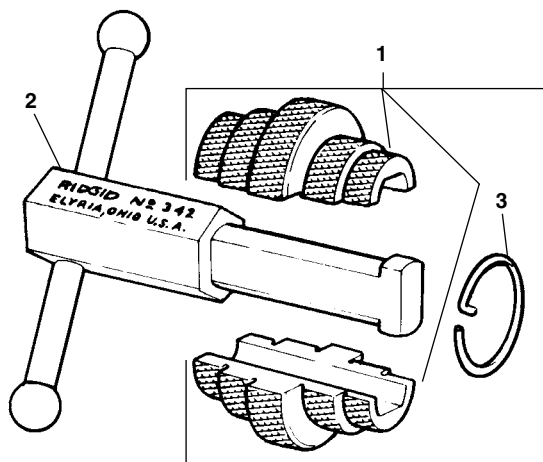

Ref. No.	Catalog No.	Description
—	31405	342 Internal Wrench
1	32795	Jaw (1 Set)
2	32790	Handle and Body Assembly
3	32800	Retainer Spring Ring

Light-Duty Chain Wrench C-12

Capacity: 2"

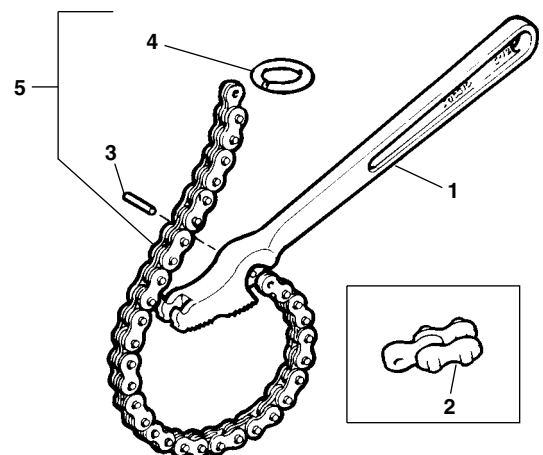

Ref. No.	Catalog No.	Description
—	31310	C-12 Chain Wrench
1	32525	Handle
2	68620	Link
3	32535	Pin
4	32555	Ring
5	32530	Chain Assembly

*Extra 68620 Chain Link Assemblies are available.

Heavy-Duty Chain Wrench

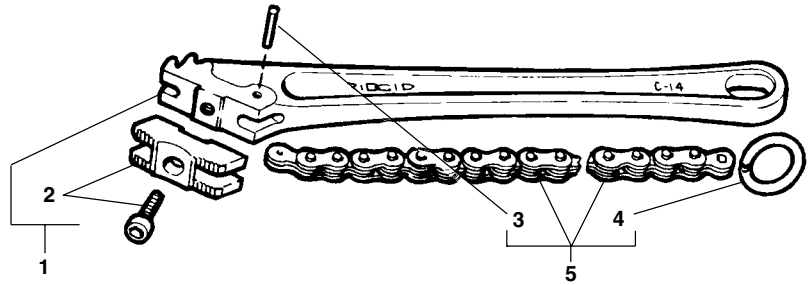

NOTE: Order parts by Catalog Number only. DO NOT order by Reference Number.

		C14 Max. 2"	C18 Max. 2½"	C24 Max. 3"	C36 Max. 4½"
Ref. No.	Description	Catalog No.	Catalog No.	Catalog No.	Catalog No.
1	Handle Assembly	32540	32565	32585	32595
2	Jaw with Screw	32550	32575	32590	32600
3	Pin	32560	32580	32580	32610
4	Ring	32555	32555	32555	32555
5	Chain Assembly	32545	32570	32570	32605
6	Link	68620	68625	68625	68630

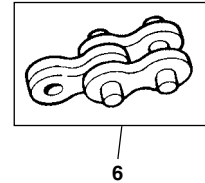

Strap Wrench

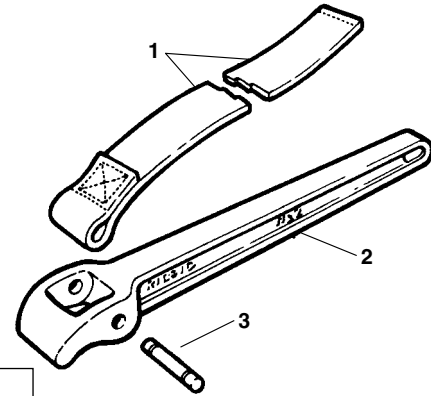

	1 ½"-2"	2 ½"-2"	2P ½"-2"	5 1"-5"	5P 1"-5"
Ref. No.	Catalog No.	Catalog No.	Catalog No.	Catalog No.	Catalog No.
1	17" Strap	32015	32035	—	—
	24" Strap	32020	—	—	—
	30" Strap	32025	—	32050	32065
	48" Strap	—	—	32055	—
2	Handle	32005	32040	32075	32075
3	Pin	32010	32045	32080	32080

Chain Tongs

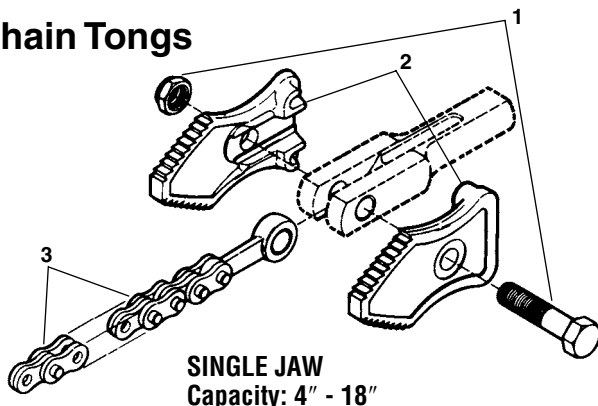

Ref. No.	Description	3215
1	Nut & Bolt	93020
2	Jaws	93015
3	Chain	93010

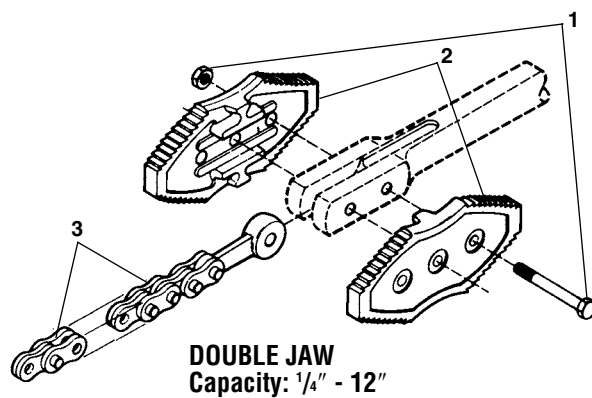

Ref. No.	Description	3229	3231	3233	3235	3237
1	Nut & Bolt	93035	93050	93050	93080	93095
2	Jaws	93030	93045	93060	93075	93090
3	Chain	93025	93040	93055	93070	93085

No. 2 Pump Gun (Used with Nos. 302 and 318 Oilers)

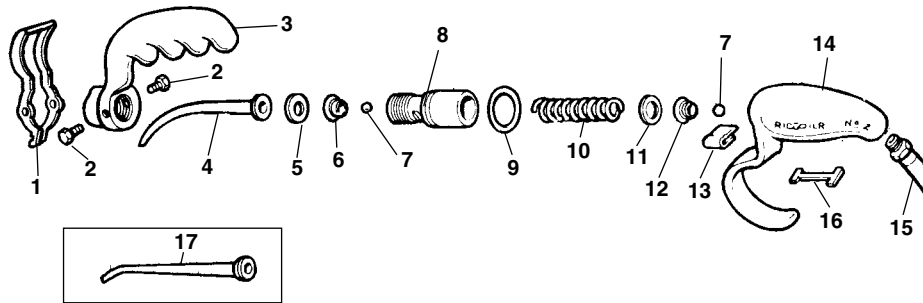

**NOTE: Order parts by Catalog Number only.
DO NOT order by Reference Number.**

Ref. No.	Catalog No.	Description	Ref. No.	Catalog No.	Description
*1	41750	Actuator	*11	41735	Stop Washer
*2	41755	Screw (2)	*12	41720	Intake Ball Spring
3	41690	Handle	*13	41695	Spring Clip
*4	41725	Spout	14	41685	Body
*5	41715	Spout Washer (Optional)	15	41775	Hose with Fittings
*6	41710	Exhaust Ball Spring	*16	41760	Link
*7	41730	Ball (2)	17	41830	Long Spout (Industrial Oiler with Small Orifice)
8	41745	Piston	*	41655	Gun Repair Kit
*9	41700	Piston "O" Ring			
*10	41740	Piston Spring			

Note: (Parts included in Gun Repair Kit)

418 Oiler

**NOTE: Order parts by Catalog Number only.
DO NOT order by Reference Number.**

Ref. No.	Catalog No.	Description
—	10883	418 All Weather Oiler
1	72332	Oiler Gun
2	73072	Hose w/Fittings
3	72327	418 Oiler Gun w/Hose
4	41660	Strainer
5	15373	Bucket Assembly

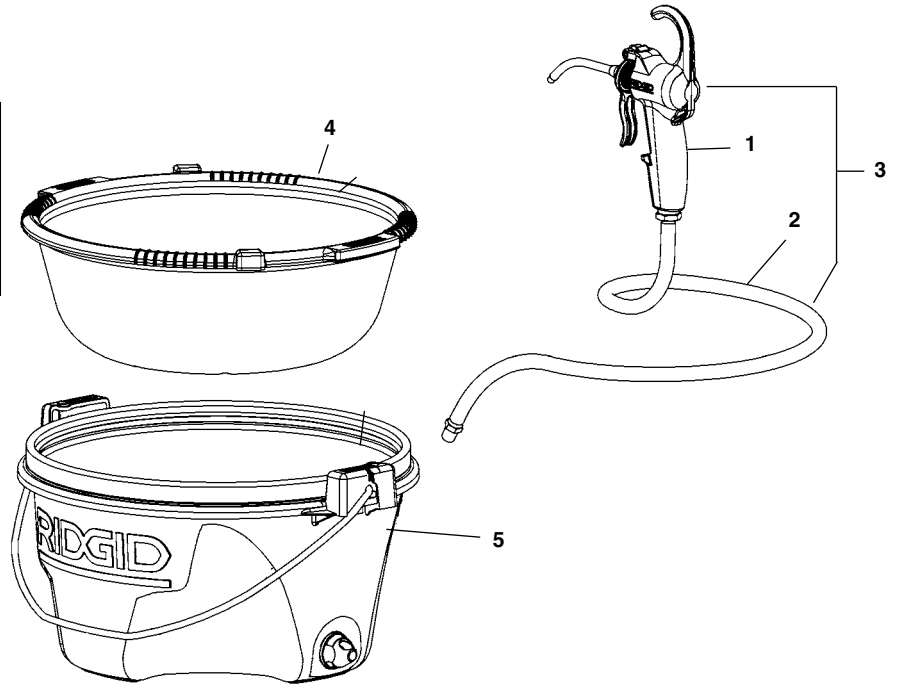

418 Bracket Assembly

Ref. No.	Catalog No.	Description
—	15373	Bucket Assembly
1	15378	Seal
2	41765	Strainer
3	40640	Hex Nut 3/4" - 16
4	41790	Washer
5	15388	O-Ring
6	15393	Swivel Coupling
7	15383	Handle

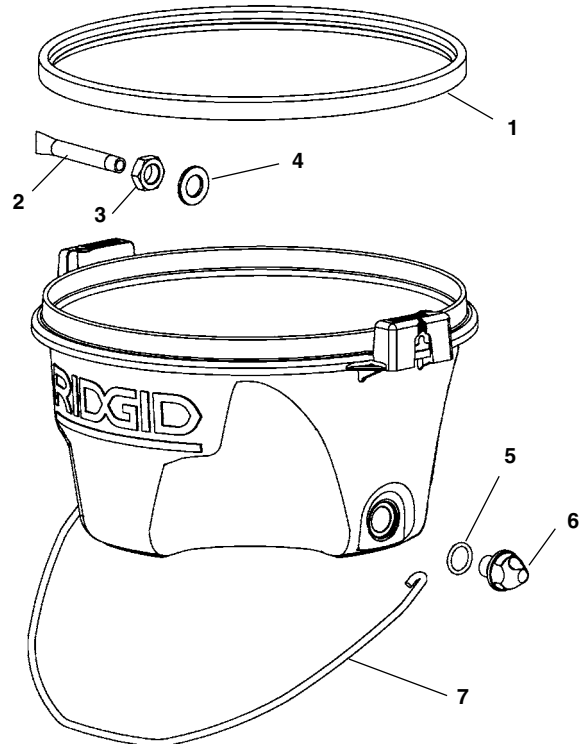

No. 4 Pump Gun

NOTE: Order parts by Catalog Number only.
DO NOT order by Reference Number.

Ref. No.	Catalog No.	Description
—	72332	No. 4 Pump Gun
—	72327	No. 4 Pump Gun w/Hose
1	73052	Trigger
*2	73047	Wear Washer
3	73042	Retainer
4	73037	Spout
*5	41715	Washer
*6	41710	Spring
*7	27653	Ball (2)
*8	73032	Piston
*9	73027	O-Ring
10	73022	Return Spring
11	73017	Body
12	42342	Pin
*13	73057	Spring
*14	73062	Fitting
15	73072	Hose w/Fittings
*	73067	Service Kit

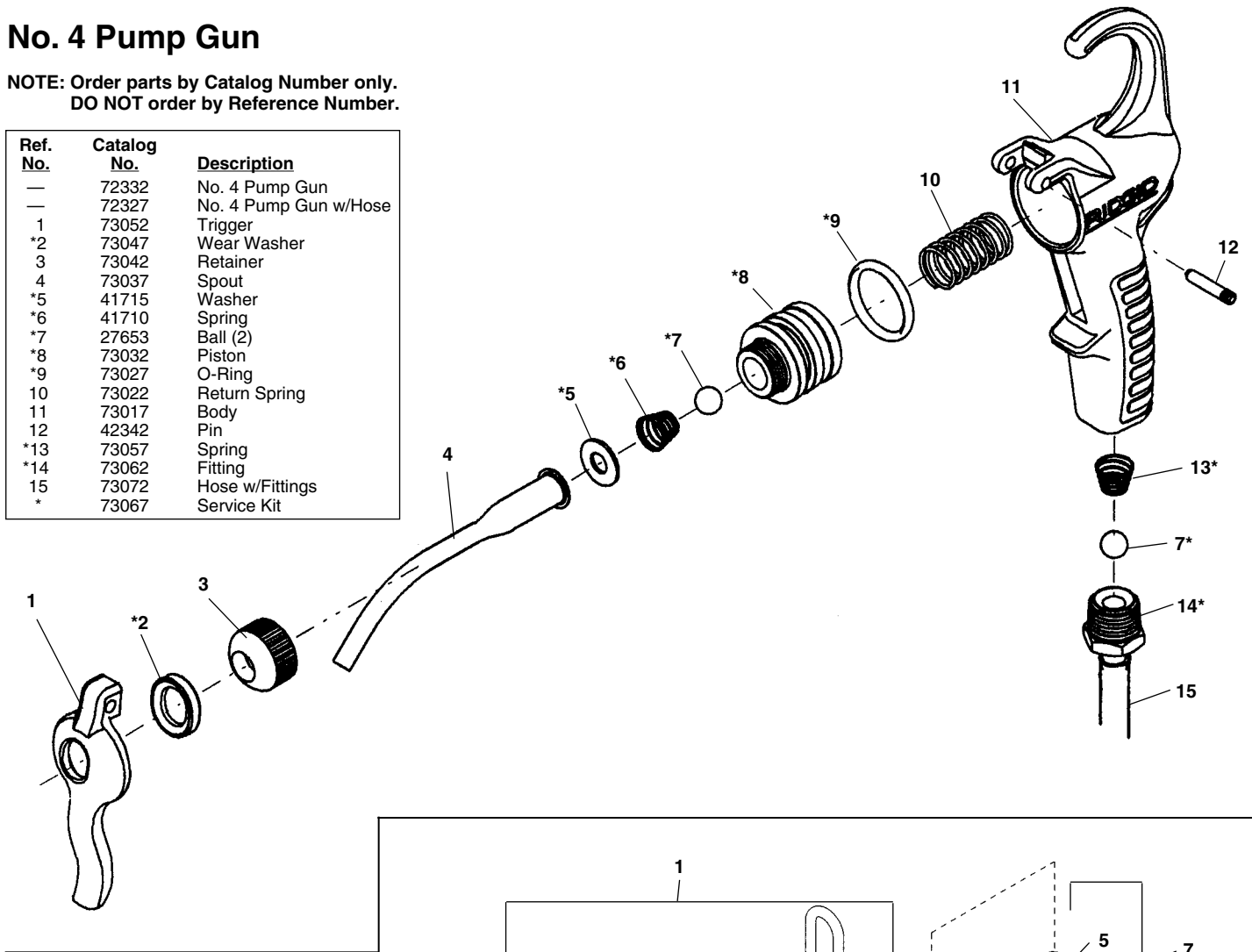

402 Utility Oiler

Ref. No.	Catalog No.	Description
—	72342	402 Utility Oiler
1	72327	No. 4 Pump Gun w/Hose & Fittings
2	72332	No. 4 Pump Gun
3	73072	Hose w/Fittings
4	41670	Extension Tube Assembly
5	41810	Lock Nut
6	41815	O-Ring
7	41820	Screw Cap & Nut Assembly
8	77995	Adapter f/Plastic Container

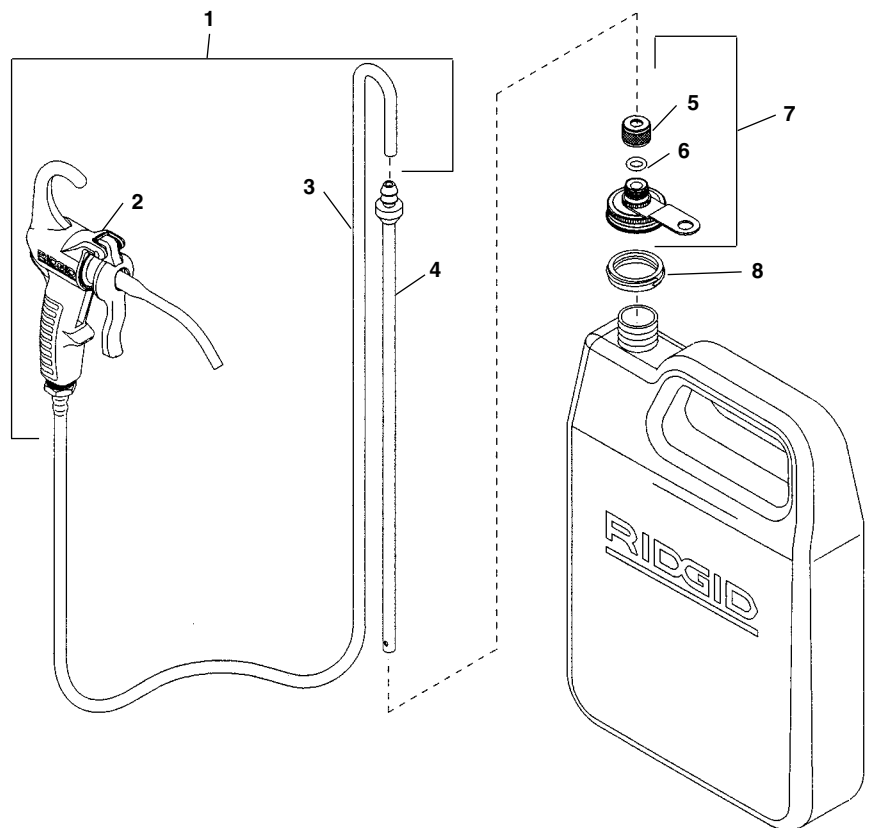

No. 2

Capacity: 1/8" – 2"

No. 3

Capacity: 3/8" – 3"

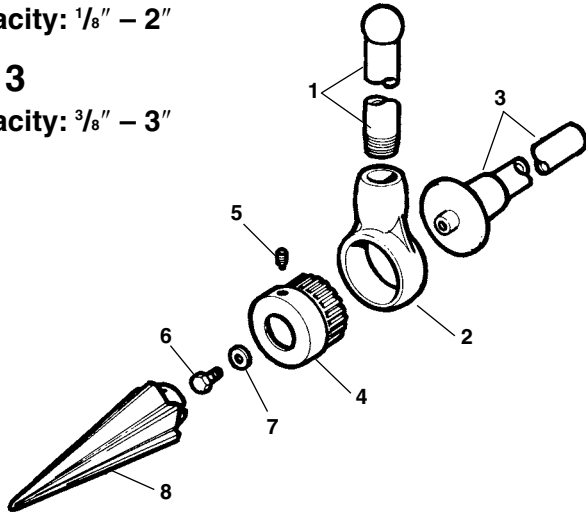

No. 2-S

Capacity: 1/8" – 2"

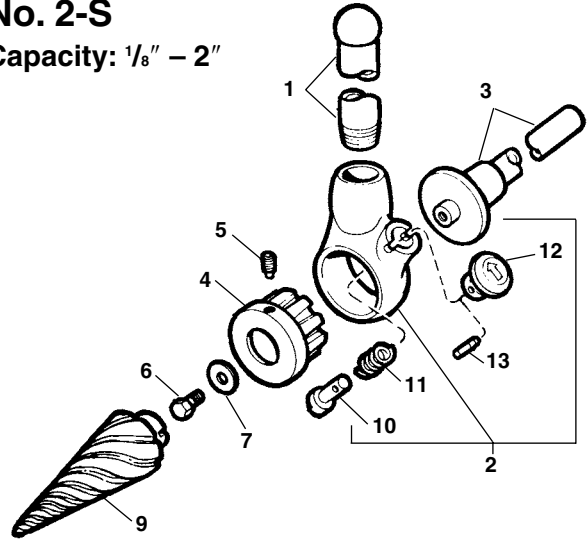

**NOTE: Order parts by Catalog Number only.
DO NOT order by Reference Number.**

Ref. No.	Description	No. 2 Catalog No.	No. 3 Catalog No.	No. 2-S Catalog No.
—	Reamer Assembly Complete	34945	35950	34955
1	Handle	35030	35030	35030
2	Ratchet Assembly w/Pawl & Spring	34980	35100	35065
3	Handgrip	34985	35115	35070
4	Ratchet Head	34990	35105	35040
5	Set Screw	35045	35045	35045
6	Screw	35050	35050	35050
7	Washer	35055	35055	35055
8	Straight Reamer Cone	34975	35090	—
9	Spiral Reamer Cone	—	—	35020
10	Pawl	—	—	38690
11	Spring	—	—	38695
12	Knob	—	—	38700
13	Pin	—	—	38705

No. 254

Capacity: 2 1/2" – 4"

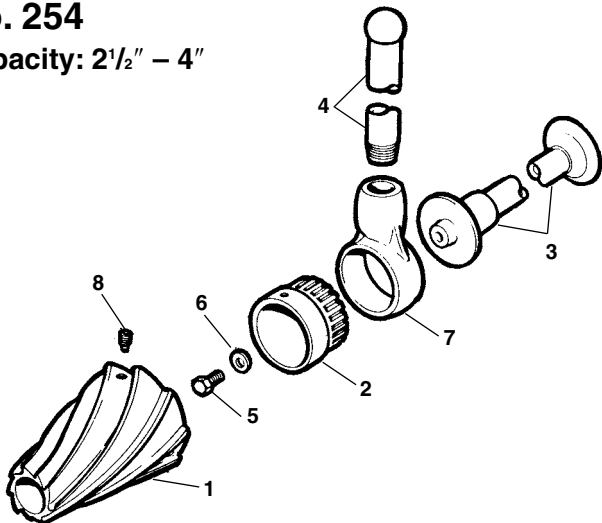

Ref. No.	Catalog No.	Description
—	34960	254 Reamer
1	35135	Spiral Reamer Cone
2	35145	Ratchet Head
3	35150	Handgrip Assembly
4	35030	Handle
5	35050	Screw
6	35055	Washer
7	35100	Ratchet Assembly w/Pawl & Spring
8	35140	Set Screw (3)

**Exposed Ratchet Type
No. 00-R**

Capacity: 1/8" through 1"

No. 111-R

Capacity: 1/8" through 1 1/4"

No. 12-R

Capacity: 1/8" through 2"

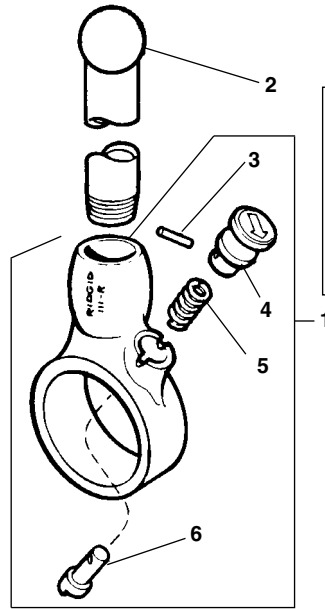

NOTE: Order parts by Catalog Number only.
DO NOT order by Reference Number.

Ref. No.	Description	Catalog No.	00-R	111-R
			Catalog No.	Catalog No.
—	Ratchet and Handle Assembly	38540	38550	38555
1	Ratchet Assembly	38565	38575	38580
2	Handle	38590	38585	38585
3	Pin	38705	38705	38705
4	Knob	38700	38700	38700
5	Spring	38695	38695	38695
6	Pawl	38690	38690	38690

12-R Type 2 Ratchet and Handle

Ref. No.	Catalog No.	Description
—	38555	Ratchet & Handle Assembly
1	38585	Handle
2	12238	Ratchet Assembly
3	16033	Pawl
4	16028	Compression Spring
5	16023	Sleeve
6	16018	Spring Wave Washer
7	16403	Retaining Ring
8	16038	Knob
9	95085	Pawl Pin

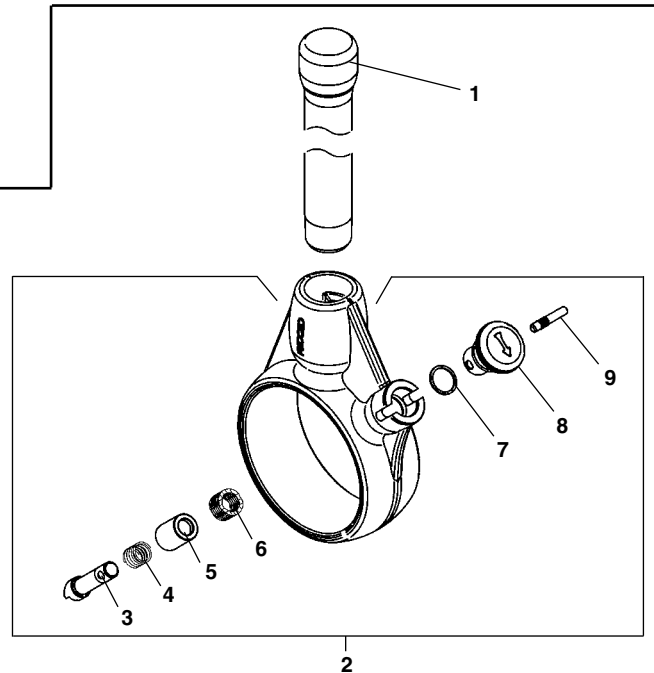

Die Head Assembly

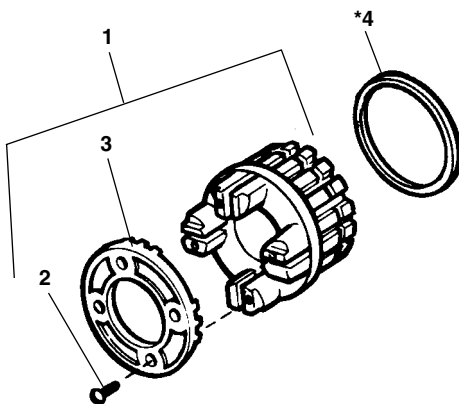

* Used on early models

Ref. No.	Description	Die Head Size	00-R	12-R	12-R IMC
			Catalog No.	Catalog No.	Catalog No.
1	Die Head w/Cover Plate & Screws	1/8"	38710	38890	—
		1/4"	38730	38900	—
		3/8"	38740	38905	—
		1/2"	38755	38910	94060
		3/4"	38765	38915	94065
		1"	38775	38920	94070
		1 1/4"	—	38925	94075
		1 1/2"	—	38930	94080
2	Cover Plate Screw (4)	1/8"-1 1/4"	38720	38720	—
		3/8"-1 1/4"	38750	38750	38750
		1 1/2"-2"	—	38940	38940
3	Cover Plate	1/8"	38715	38715	—
		1/4"	38735	38735	—
		3/8"	38745	38745	—
		1/2"	38760	38760	38760
		3/4"	38770	38770	38770
		1"	38780	38780	38780
		1 1/4"	—	38880	38880
		1 1/2"	—	38935	38935
		2"	—	38950	38950
		4	Spring Ring		*38725

R-200/11-R Ratchet Assembly

NOTE: Order parts by Catalog Number only.
DO NOT order by Reference Number.

Ref. No.	Catalog No.	Description
—	37777	Ratchet & Handle Assembly
1	38585	Handle
2	39177	Ratchet Assembly
3	39197	Knob
4	39182	Ratchet Housing
5	39172	Spring - Housing
6	39187	Ratchet Ring
7	38830	Spring - Ratchet Ring
8	39192	Pawl
9	39202	Pawl Spring

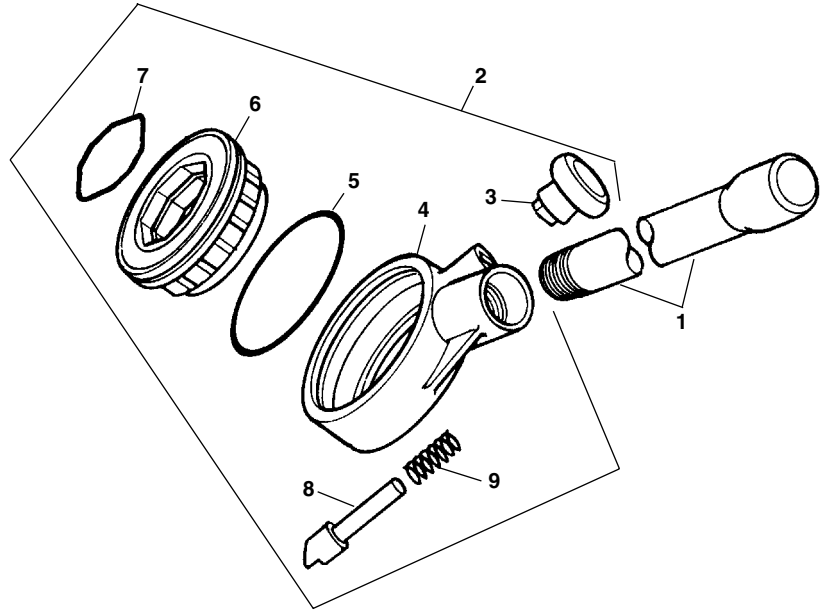

11-R Die Head Assembly

		11-R	
Ref. No.	Description		Catalog No.
1	Die Head w/Cover Plate & Screws	1/8"	38785
		1/4"	38790
		3/8"	38795
		1/2"	38800
		3/4"	38805
		1" NPT/NPSM	38810
		1" BSPT/BSPP	74995
		1 1/4" NPT/NPSM	38815
		1 1/4" BSPT/BSPP	41467
		1 1/2"	20963
		2"	20968
		16mm ISO	41477
		20mm ISO	41482
		25mm ISO	41487
32mm ISO	41482		
40mm ISO	41497		
2	Cover Plate Screw (4)	1/8"-1/4"	38720
		3/8"-1 1/4"	38750
		1 1/2"-2"	38940
		16mm - 40mm	38750
3	Cover Plate	1/8"	38715
		1/4"	38735
		3/8"	38745
		1/2"	38760
		3/4"	38770
		1"	38780
		1 1/4"	38880
		1 1/2"	38935
		2"	38950

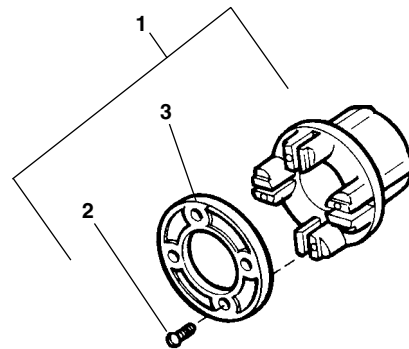

00-RB Die Head Assembly

Capacity: 1/4" through 1"

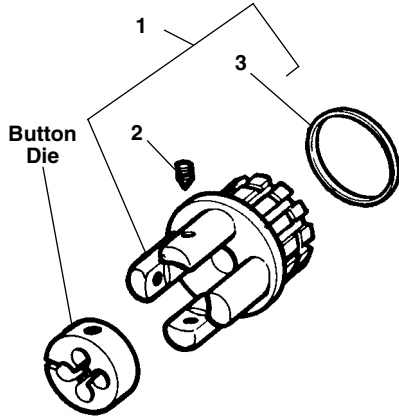

NOTE: Order parts by Catalog Number only.
DO NOT order by Reference Number.

Ref. No.	Catalog No.	Description
1	38960	1/4" Die Head
	38965	5/16" Die Head
	38970	3/8" Die Head
	38975	7/16" Die Head
	38980	1/2" Die Head
	38985	9/16" Die Head
	38990	5/8" Die Head
	38995	3/4" Die Head
	39000	7/8" Die Head
	39005	1" Die Head
2	39020	Screw (3)
3	38725	Spring Ring

3-Way Pipe and Conduit Threaders

No. 30-A Capacity: 3/8" through 3/4"

No. 31-A Capacity: 1/2" through 1"

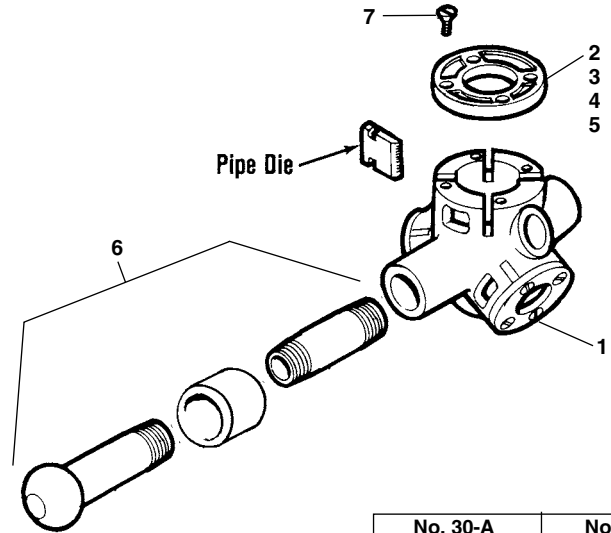

Ref. No.	Description	No. 30-A	No. 31-A
		Catalog No.	Catalog No.
1	Body	39230	39235
2	1" Cover Plate	—	39710
3	3/4" Cover Plate	39715	39715
4	1/2" Cover Plate	39720	39720
5	3/8" Cover Plate	38745	—
6	Handle (2)	38590	38590
7	Cover Plate Screw (4)	38750	38750

Note: Refer to Tool Price List when ordering Dies

3-Way Bolt Threaders

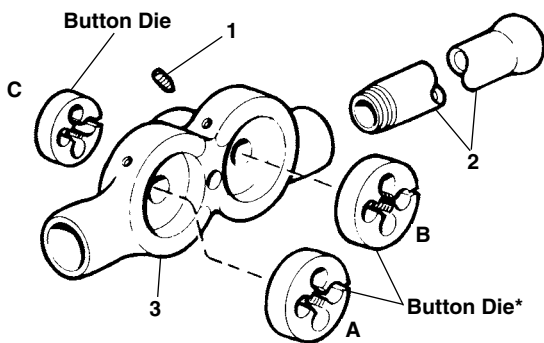

Ref. No.	Description	31-B	33-B	35-B	37-B
		1/4"-1/2"	3/8"-5/8"	1/2"-5/8"	3/4"-1"
Catalog No.		Catalog No.	Catalog No.	Catalog No.	Catalog No.
1	Screw (9)	39015	39015	39015	39015
2	Handle (2)	39045	39045	39045	39535
3	Body	39025	39030	39035	39040

* Refer to Die Table.

Refer to A, B & C For Button Die Combinations												
Model No.	31-B			33-B			35-B			37-B		
O.D. of Button Die	1"	1"	1 1/2"	1"	1 1/2"	1 1/2"	1 1/2"	1 1/2"	1 1/2"	2"	2"	2 1/4"
Button Die Location	A	B	C	A	B	C	A	B	C	A	B	C
Rod Diameter	1/4"	3/8"	1/2"	3/8"	1/2"	5/8"	1/2"	9/16"	5/8"	3/4"	7/8"	1"
		5/16"	9/16"	1/4"		9/16"						
		7/16"	5/8"	5/16"								
				7/16"								

NOTE: 1. 00-RB Dies are interchangeable w/above Button Dies.
2. To use 7/16" Button Die in 31-B or 33-B enlarge Pilot Hole to 15/32".
3. To use 9/16" or 5/8" Button Dies in 31-B enlarge Pilot Hole to 19/32" or 21/32".

Nos. 65R-C & 65R-TC
Capacity: 1", 1 1/4", 1 1/2" and 2"

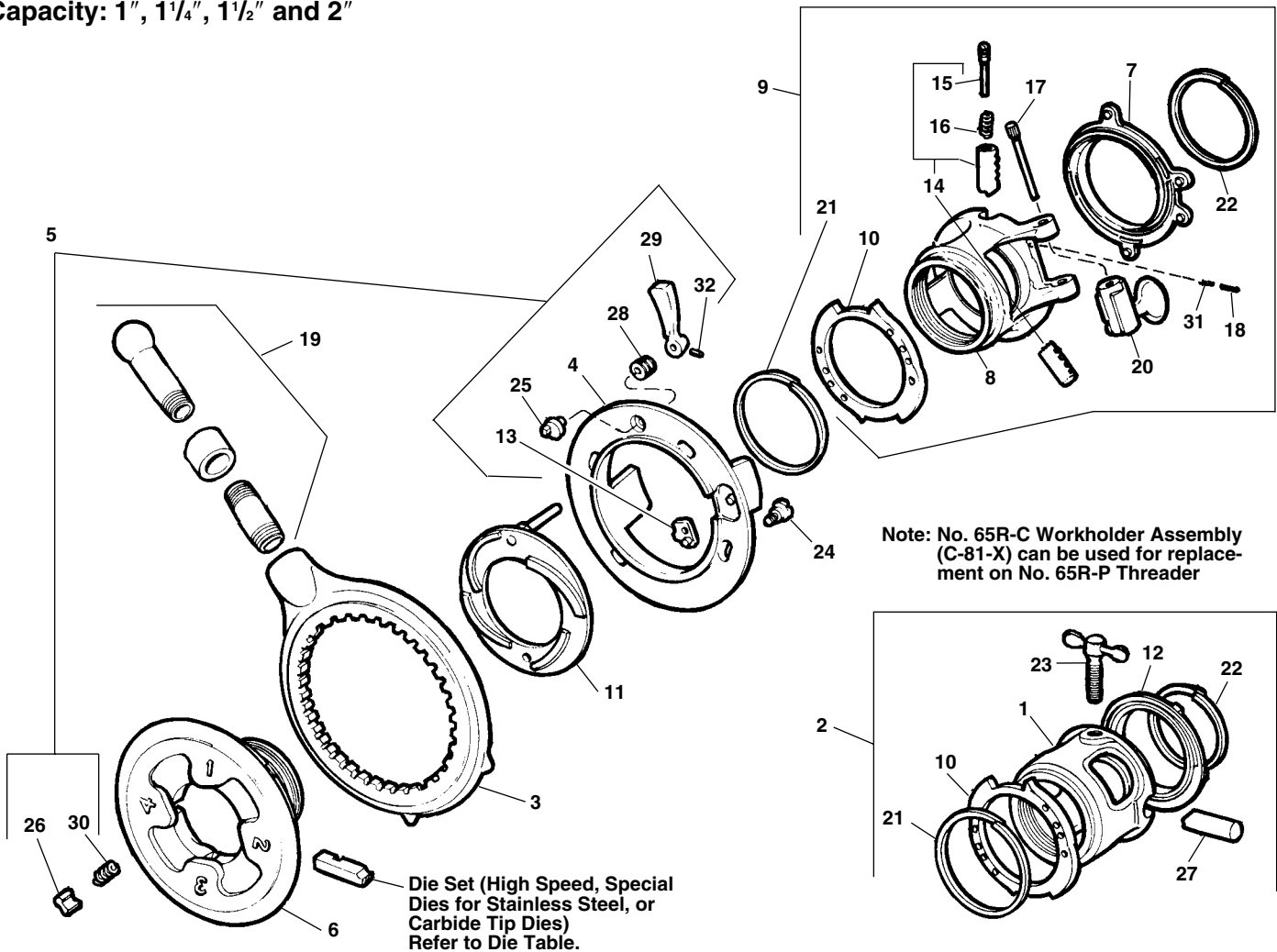

Note: No. 65R-C Workholder Assembly (C-81-X) can be used for replacement on No. 65R-P Threader

NOTE: Order parts by Catalog Number only.
DO NOT order by Reference Number.

Ref. No.	Catalog No.	Description	Ref. No.	Catalog No.	Description
1	39335	65R-C Workholder (Cam Type) N.P.T.	15	39485	Set Screw
	68100	65R-C Workholder (Cam Type) B.S.P.T.	16	39490	Compression Spring
2	39340	65R-C Workholder Assy. (Cam Type) N.P.T.	17	39500	Locking Cam Pin
	68110	65R-C Workholder Assy. (Cam Type) B.S.P.T.	18	39505	Stop Pin
3	39205	Ratchet Ring	19	39545	Pipe Handle
4	39215	Drive Plate	20	39555	Locking Cam
5	39220	Jam Proof Drive Plate Assembly	21	39975	Change Plate Spring Ring
6	39245	Head N.P.T.	22	39980	Gauge Plate Spring Ring
	68060	Head B.S.P.T.	23	39985	Clamp Screw
7	39290	Gauge Ring	24	39990	Drive Plate Screw (4)
8	39295	Tru-Center Workholder N.P.T.	25	39995	Release Cam
	68070	Tru-Center Workholder B.S.P.T.	26	39875	Pawl (2)
9	39300	65R Tru-Center Workholder Assy. N.P.T.	27	39880	Workholder Jaw (2)
	68075	65R Tru-Center Workholder Assy. B.S.P.T.	28	39885	Release Cam Flat Spring (2)
10	39400	Change Plate N.P.T.	29	39895	Release Cam Lever
	68125	Change Plate B.S.P.T.	30	39900	Pawl Spring (2)
11	39450	Cam Plate	31	39915	Coil Spring
12	39370	Gauge Ring	32	39965	Cam Lever Pin
13	39405	Throwout Plate			
14	39425	Workholder Jaw (3 per set) (2 solid & 1 spring loaded)			

Capacity: 2 1/2", 3", 3 1/2", & 4"

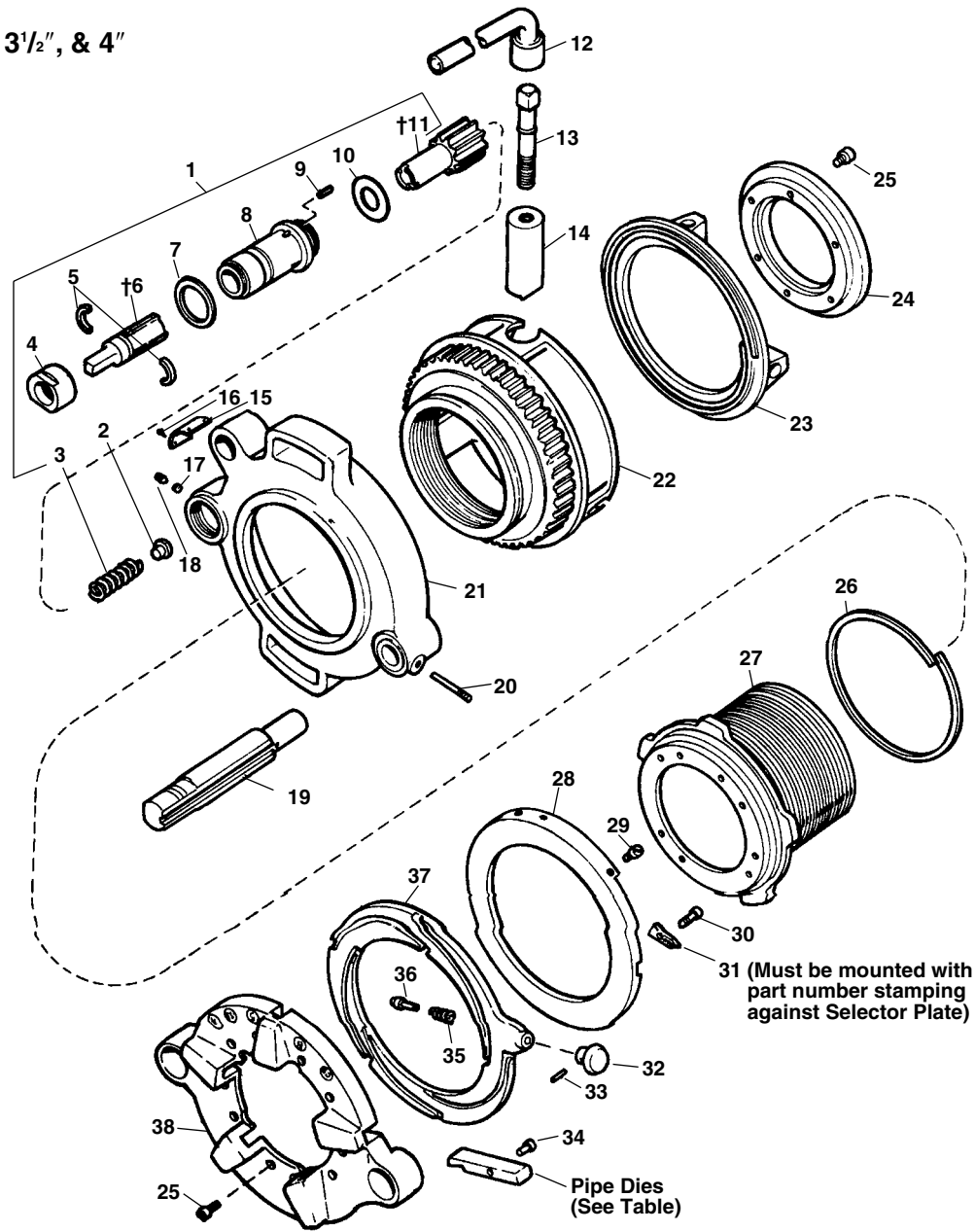

**NOTE: Order parts by Catalog Number only.
DO NOT order by Reference Number.**

Ref. No.	Catalog No.	Description	Ref. No.	Catalog No.	Description	Ref. No.	Catalog No.	Description
1	39360	Pinion Shaft Assembly	14	39345	Workholder Jaw (3)	27	39320	NPT Threaded Barrel
2	39810	Wear Plug	15	39835	Name Plate	68090	68090	BSPT Threaded Barrel
3	39815	Spring	16	46870	Drive Screw (4)	28	39185	NPT Selector Plate
4	39605	Pinion Shaft Retaining Collar	†17	32755	Nylon Plug	39190	39190	BSPT Selector Plate
5	39695	Split Ring	18	58720	Set Screw	39110	39110	Selector Plate i/Cast Iron
†6	39465	Drive Shaft	19	39330	NPT Guide Post	29	39790	Stop Screw
7	39615	Pressure Ring		68020	BSPT Guide Post	30	39830	Guide Block Screw
8	39825	Pinion Sleeve	20	39650	Guide Post Screw	31	39655	Guide Block
9	39620	Pressure Pin (3)	21	39200	Gear Case	32	39645	Knob (2)
10	39625	Pinion Shaft Ring	22	39195	NPT Workholder	33	44925	Pin (2)
†11	39470	Pinion Shaft with Gear		68040	BSPT Workholder	34	39750	Die Pins & Clips
12	39585	Wrench	23	39100	Workholder Scroll	35	39690	Spring (2)
	29056	Wrench (Europe Hex-Key)	24	39455	Retaining Ring	36	39640	Locating Pin (2)
13	39795	Clamp Screw with Clip	25	32275	Screw (16)	37	39180	Cam Plate
	29046	Clamp Screw with Clip (Europe)	26	39730	Gear Case Spring Ring	38	39175	Head

Service Notes: (Ref. No. 6) (Ref. No. 11) Early Models incorporating 39600/E-1936 Pinion Shaft and 3590/E-1935-1 Drive with 39630/E-1945-1 Centering Pin can be updated by using new style Pinion Shaft or new style Drive Shaft and discarding Centering Pin.
(Ref. No. 17) Nylon Plug should be replaced anytime Pinion Shaft Assembly (Ref. No. 1) is removed from Gear Case.

Ratchet and Handle

No. D-1440

NOTE: Used with Nos. 4PJ, 141 and 161 Threaders. Also fits Toledo-Beaver, Nye & Armstrong 4' Geared Threaders & Cut-off Tools.

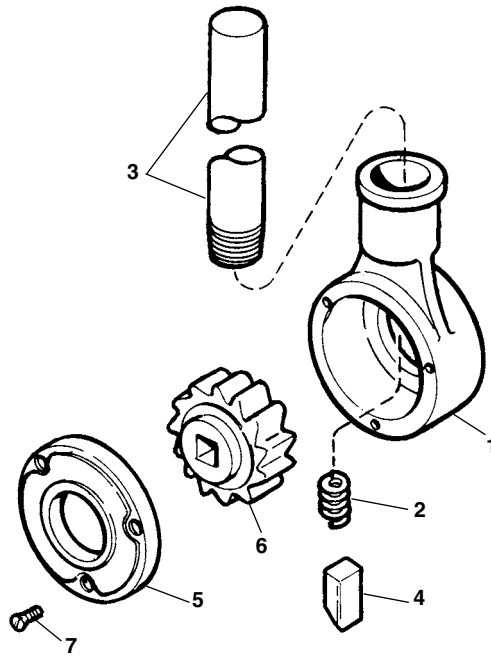

NOTE: Order parts by Catalog Number only.
DO NOT order by Reference Number.

Ref. No.	Catalog No.	Description
1	39390	Ratchet Case
2	38695	Pawl Spring
3	39420	Handle
4	39940	Pawl
5	39800	Ratchet Cover
6	39805	Ratchet Wheel
7	39570	Cover Screw (3)

Capacity: 4", 4½", 5", & 6"

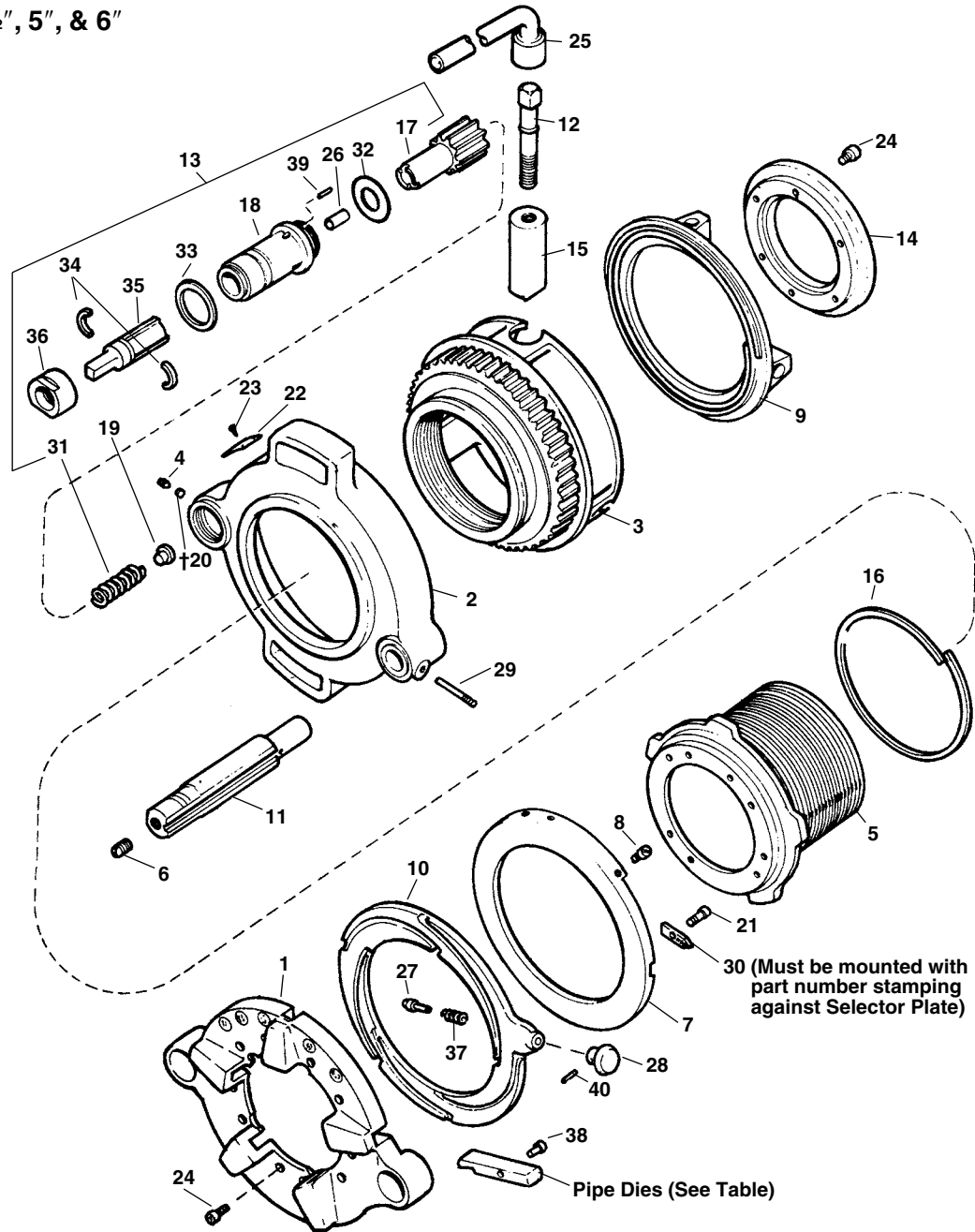

**NOTE: Order parts by Catalog Number only.
DO NOT order by Reference Number.**

Ref. No.	Catalog No.	Description	Ref. No.	Catalog No.	Description	Ref. No.	Catalog No.	Description
1	39085	Head	14	39350	Retaining Plate	28	39645	Knob (2)
2	39090	Gear Case	15	39355	Workholder Jaw (3 per set)	29	39650	Screw
3	39095	Workholder (NPT)	16	39430	Gear Case Spring Ring	30	39655	Guide Block
4	58720	Set Screw	17	39365	Pinion Shaft with Gear	31	39660	Spring
5	39160	Threaded Barrel (NPT)	18	39435	Pinion Sleeve	32	39665	Pinion Shaft Ring
6	39780	Set Screw	19	39810	Wear Plug	33	39670	Pressure Ring
7	39165	Selector Plate (NPT)	†20	32755	Nylon Plug	34	39675	Split Ring
8	39115	Selector Plate (Cast Iron)	21	39830	Guide Block Screw	35	39680	Drive Shaft
9	39790	Stop Screw	22	39840	Name Plate	36	39685	Retaining Collar
10	39105	Workholder Scroll	23	46870	Drive Screw (4)	37	39690	Spring (2)
11	39310	Cam Plate	24	32270	Screw (16)	38	39700	Die Pin and Clip (Set of 5)
12	39315	Guide Post (NPT)	25	39585	Wrench	39	39705	Pressure Pin (3)
13	39325	Pinion Shaft Assembly	26	39630	Center Pin	40	44925	Pin (2)
			27	39640	Locating Pin (2)			

† Service Note: Nylon Plug (Ref. No. 20) should be replaced any time pinion shaft assembly (Ref. No. 13) is removed from gear case

No. 965
(Adjustable from 26" to 40")

NOTE: Order parts by Catalog Number only.
DO NOT order by Reference Number.

Ref. No.	Catalog No.	Description
1	89020	Screw (4)
2	87840	Spacer (4)
3	87835	Roller (4)
4	40350	Jam Nut
5	35045	Set Screw
6	83890	Nut (4)
7	89005	Roller Bracket
8	58535	Washer
9	89010	Screw
10	89015	Lower Post
11	89075	Base

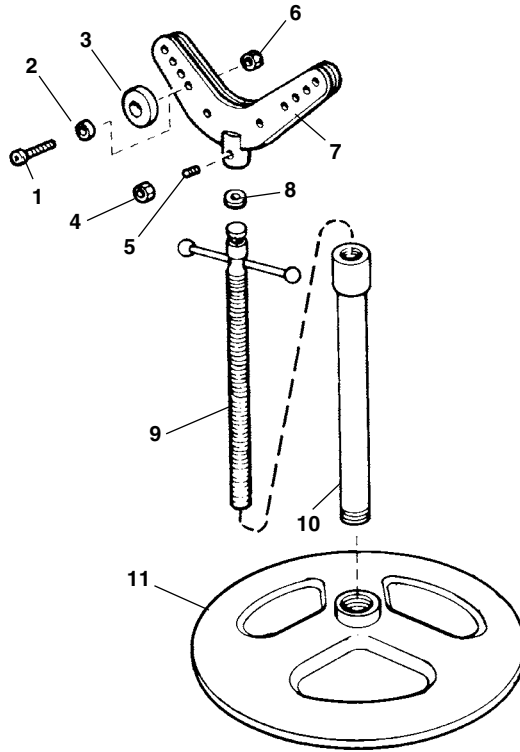

No. 46

No. 92

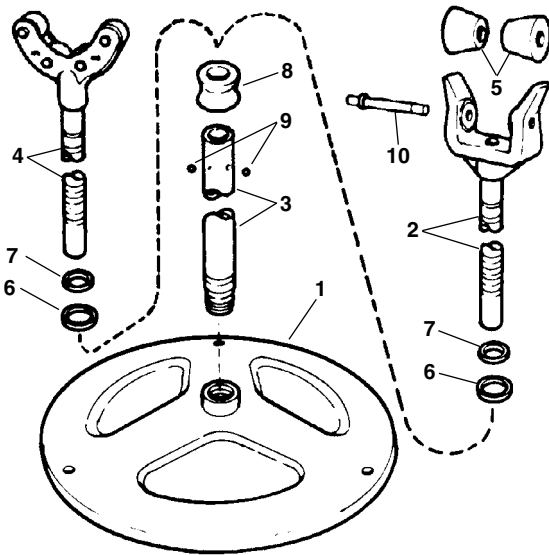

Ref. No.	Description	No. 46	No. 92
		Catalog No.	Catalog No.
1	Base	42515	42515
2	Upper Post & Frame Assembly		42520
3	Lower Post	42530	42525
4	Post, Bracket & Roll Assembly	42535	
5	Roller (2)		42540
6	Lower Spring Ring	42550	42550
7	Upper Spring Ring	42555	42555
8	Adjusting Collar	42545	42545
9	Ball (4)	42560	42560
10	Shaft, Spring & Clip Assembly		42565

(Adjustable from 23" to 33")

(Adjustable from 32" to 41")

CJ-98
CJ-99
RJ-98
RJ-99
VJ-98
VJ-99

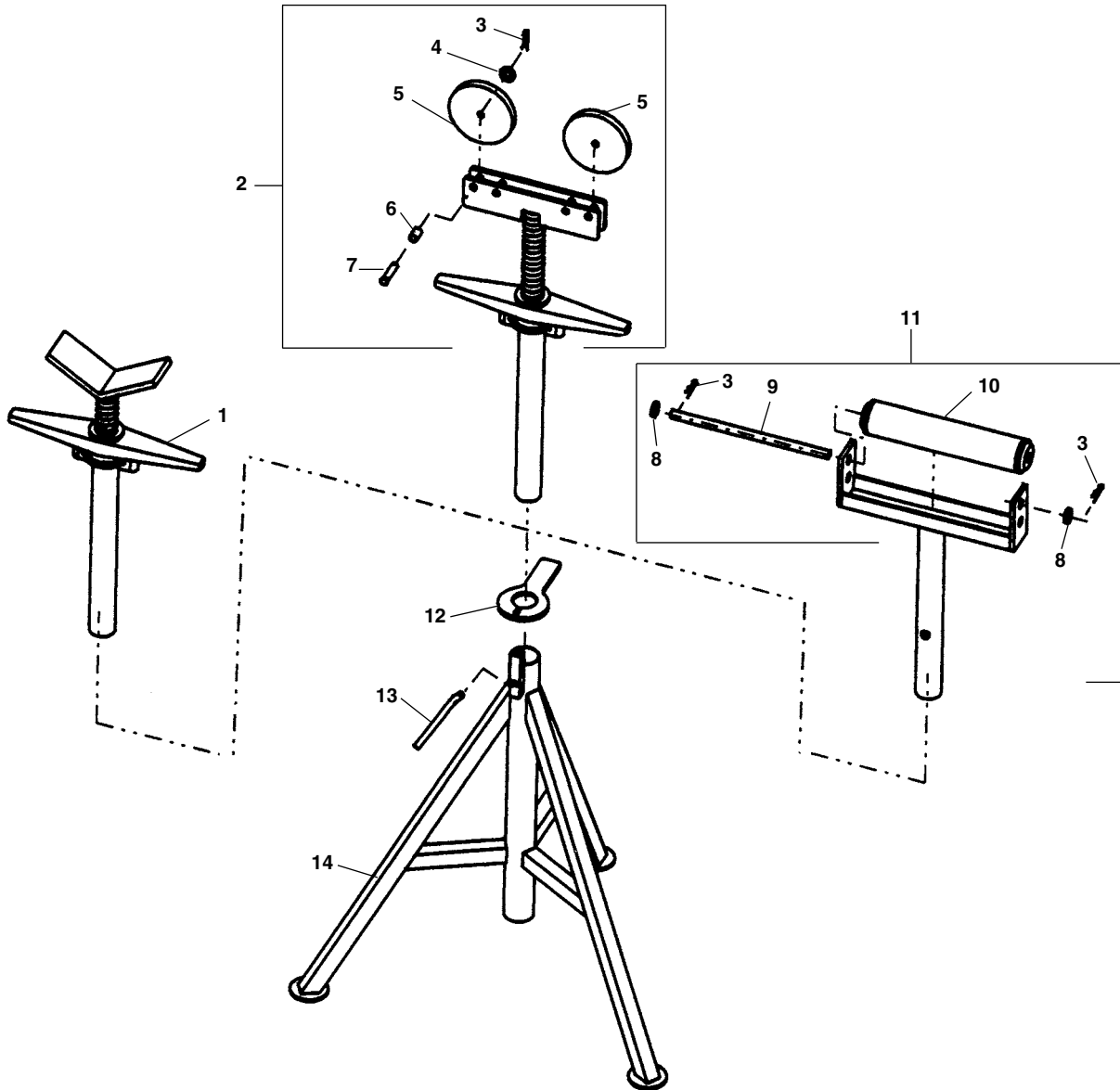

**NOTE: Order parts by Catalog Number Only.
 DO NOT order by Reference Number.**

Ref. No.	Catalog No.	Description	Ref. No.	Catalog No.	Description
	56657	VJ-98 Low "V" Stand	6	66602	Sleeve (2)
	56662	VJ-99 High "V" Stand	7	66597	Clevis Pin (2)
	56667	RJ-98 Low Roller Stand	8	60847	Washer (2)
	56672	RJ-99 High Roller Stand	9	66607	Roller Pin (CJ)
	56677	CJ-98 Low Conveyor Stand	10	59432	Roller (CJ)
	56682	CJ-99 High Conveyor Stand	11	59427	CJ-98 Head Assy. (Low)
1	59417	VJ-98 Head Assy. (Low)		59492	CJ-99 Head Assy. (High)
	59482	VJ-99 Head Assy. (High)			(Incl. Ref. No. 3, 8-10)
2	59422	RJ-98 Head Assy. (Low)	12	59442	Locking Ring
	59487	RJ-99 Head Assy. (High)	13	15832	Hand Screw
		(Incl. Ref. No. 3-7)	14	59447	Base 98 (Low)
3	66592	Hair Pin (2)		59452	Base 99 (High)
4	59970	Washer (2)			
5	59437	Roller (RJ)			

RJ-624

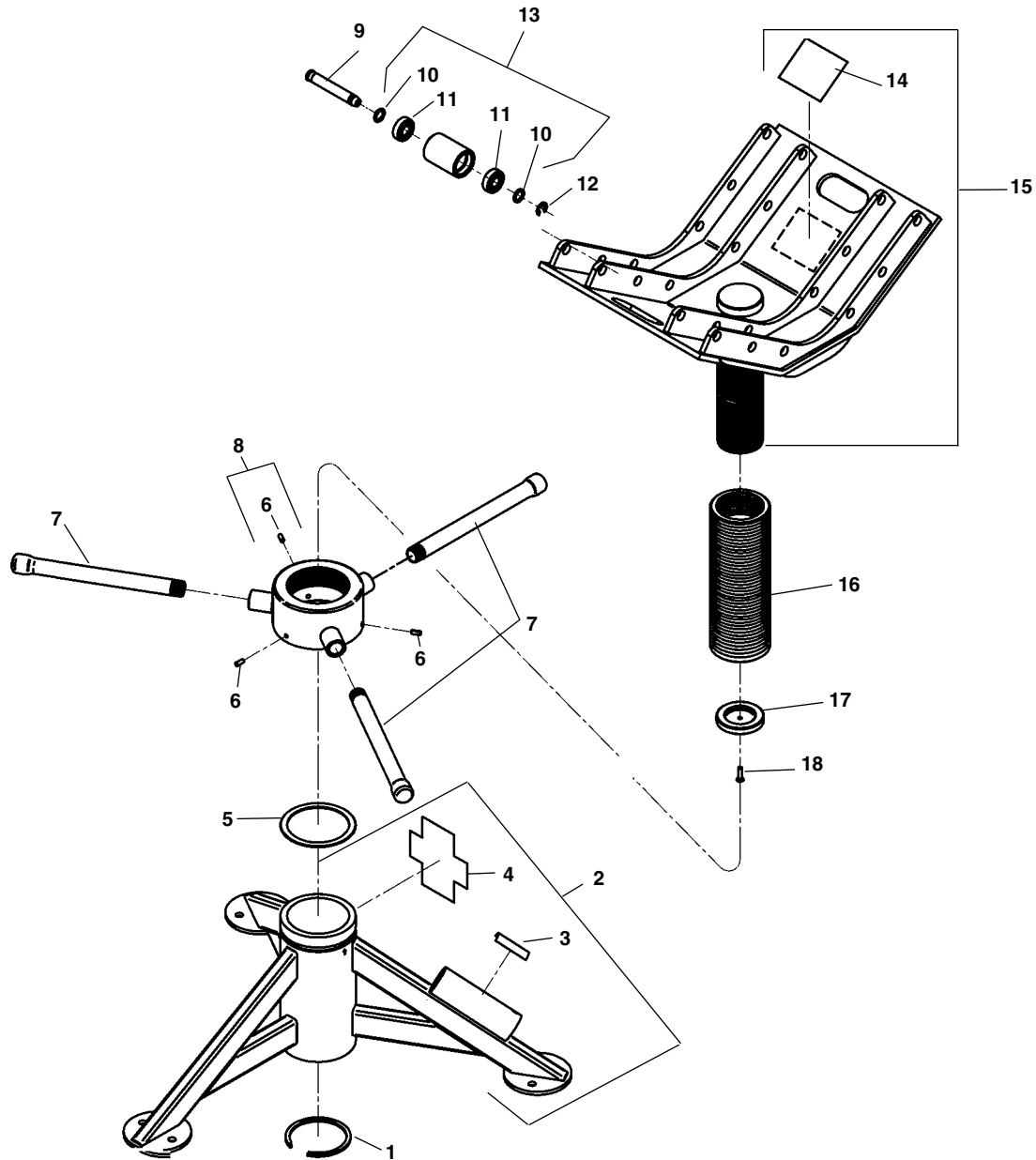

**NOTE: Order parts by Catalog Number only.
DO NOT order by Reference Number.**

Ref. No.	Catalog No.	Description	Ref. No.	Catalog No.	Description
—	96372	RJ-624 Pipe Stand	10	10648	Spacer
1	10643	Internal Retaining Ring	11	44565	Roller Ball Bearing
2	10638	Base (Inc. Ref. 3, 4)	12	42580	External Retaining Ring
3	10678	Label, Caution Label	13	50837	Roller (Inc. Ref. 10,11)
4	10868	Decal, Stand	14	10683	Warning Label
5	10633	Height Adjustment Bushing,	15	10653	Cradle
6	10623	Roll Pin	16	10658	Outer Telescopic Screw
7	10628	Height Adjustment Handle	17	10663	Inner Telescopic Cap
8	10618	Height Adjustment Nut	18	10668	Flat Hex Hd Screw
9	54887	Roller Pin (Inc. Ref. 12)			

AR-99

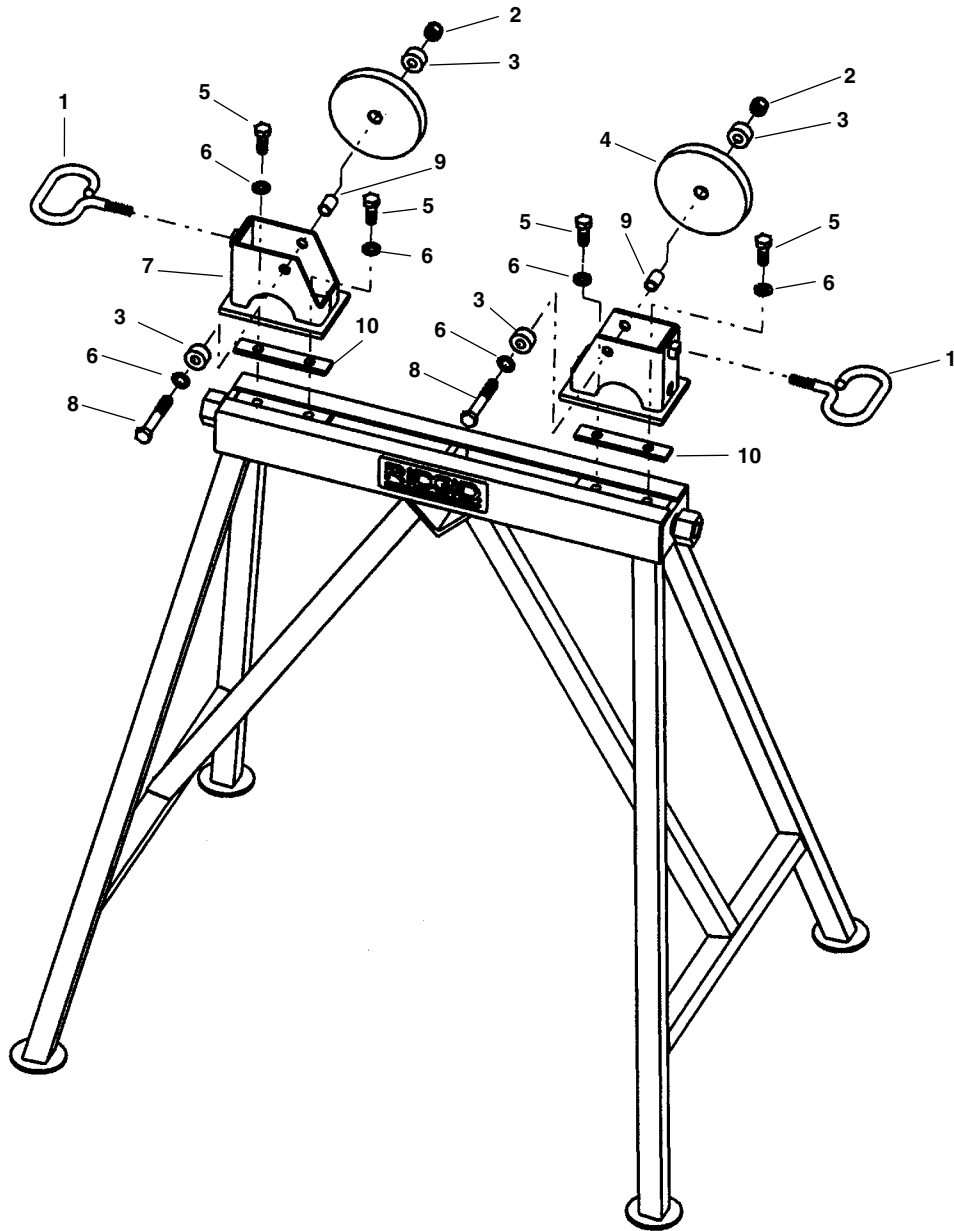

**NOTE: Order parts by Catalog Number only.
DO NOT order by Reference Number.**

Ref. No.	Catalog No.	Description
—	64642	AR-99 Adj. Roller Stand
1	66612	Handle Assembly (2)
2	83545	$\frac{3}{8}$ " x 16 Hex Jam Nut (2)
3	66617	Spacer (4)
4	59437	Roller (2)
5	80030	$\frac{3}{8}$ " x 1" Hex Bolt (4)
6	40930	Washers (4)
7	66622	Roller Holder (2)
8	58052	$\frac{3}{8}$ " x 2 $\frac{1}{8}$ " Hex Bolt (2)
9	66602	Roller Bushing (2)
10	66632	Spacer (2)

No-Hub® Soil Pipe
Capacity: 2" – 6"

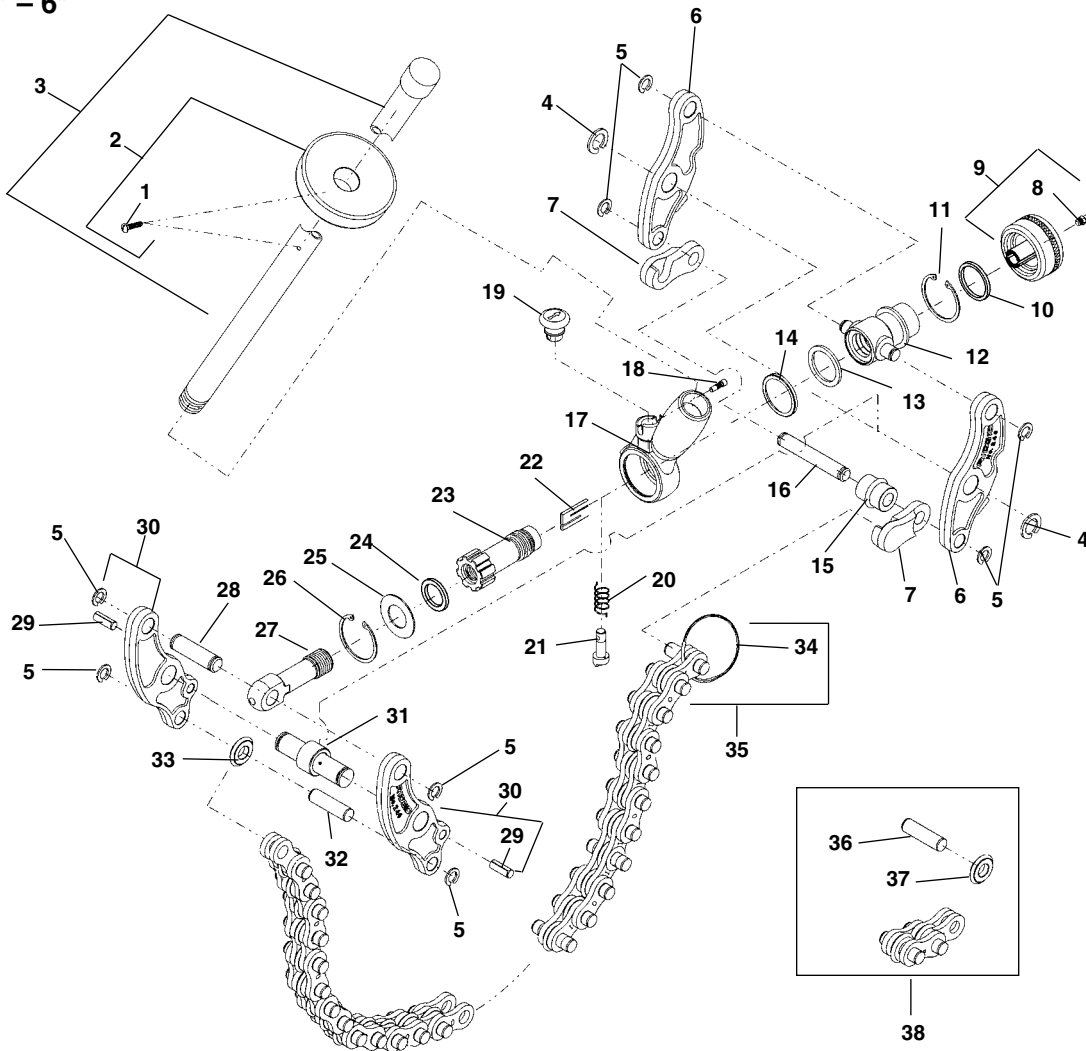

**NOTE: Order parts by Catalog Number only.
DO NOT order by Reference Number.**

Ref. Catalog No.	No.	Description	Ref. Catalog No.	No.	Description	Ref. Catalog No.	No.	Description
—	68650	206 Soil Pipe Cutter	13	33715	Seal	26	33695	Retaining Ring
1	46470	Set Screw	14	33625	Cup	27	33615	Eyebolt
2	33440	Handle Stop Assembly	15	33635	Spacer Wheel Assy. (Incl. Ref. 5)	28	33730	Pin
3	33740	Handle Assembly	16	33650	Pin	29	51502	Spiral Pin
4	33690	Retaining Ring (2)	17	33425	Ratchet Assembly (Incl. Ref. 18-21)	30	34187	Side Arm (Inside) (2)
5	33685	Retaining Ring (8)	18	38705	Pawl Pin	31	33640	Center Pin Assembly
6	34192	Side Arm Outside (2)	19	38700	Ratchet Knob	32	33645	Pin
7	33605	Hook Assembly	20	33725	Pawl Spring	33	33630	Cutter Wheel Assembly (Incl. Ref. 5)
8	46860	Grease Fitting	21	38690	Ratchet Pawl	34	33675	Ring
9	33595	Knob Assembly	22	33770	Drive Blade	35	33670	Chain Assembly
10	33710	Seal	23	33435	Ratchet Shaft Assembly	36	33680	Cutter Pin
11	33700	Retaining Ring	24	33705	Seal	37	33220	Cutter Wheel
12	33430	Trunnion	25	33620	Washer	38	33665	Chain Extension Assembly

* **33665 CHAIN EXTENSION ASSEMBLY** – Includes 33220 Cutter Wheels (2), 33655 Inside Links (2), 336601 Outside Links (2) and 33680 Cutter Pins (2) per section. Each section is approximately 3 inches long.

* **33665 CHAIN EXTENSION ASSEMBLY** is completely assembled, except for one cutter wheel and one pin, packed loose. These are needed to make the connection on the existing chain. Each section is approximately 3 inches long. Remove the 33675 Ring at the end of the existing chain...connect the loose wheel and pin to the inner link on the chain. Attach the 33675 Ring to the end of the chain extension.

WARNING: Do not cut soil pipe larger diameter than: Clay - 12" diameter; Cast Iron - 8" diameter

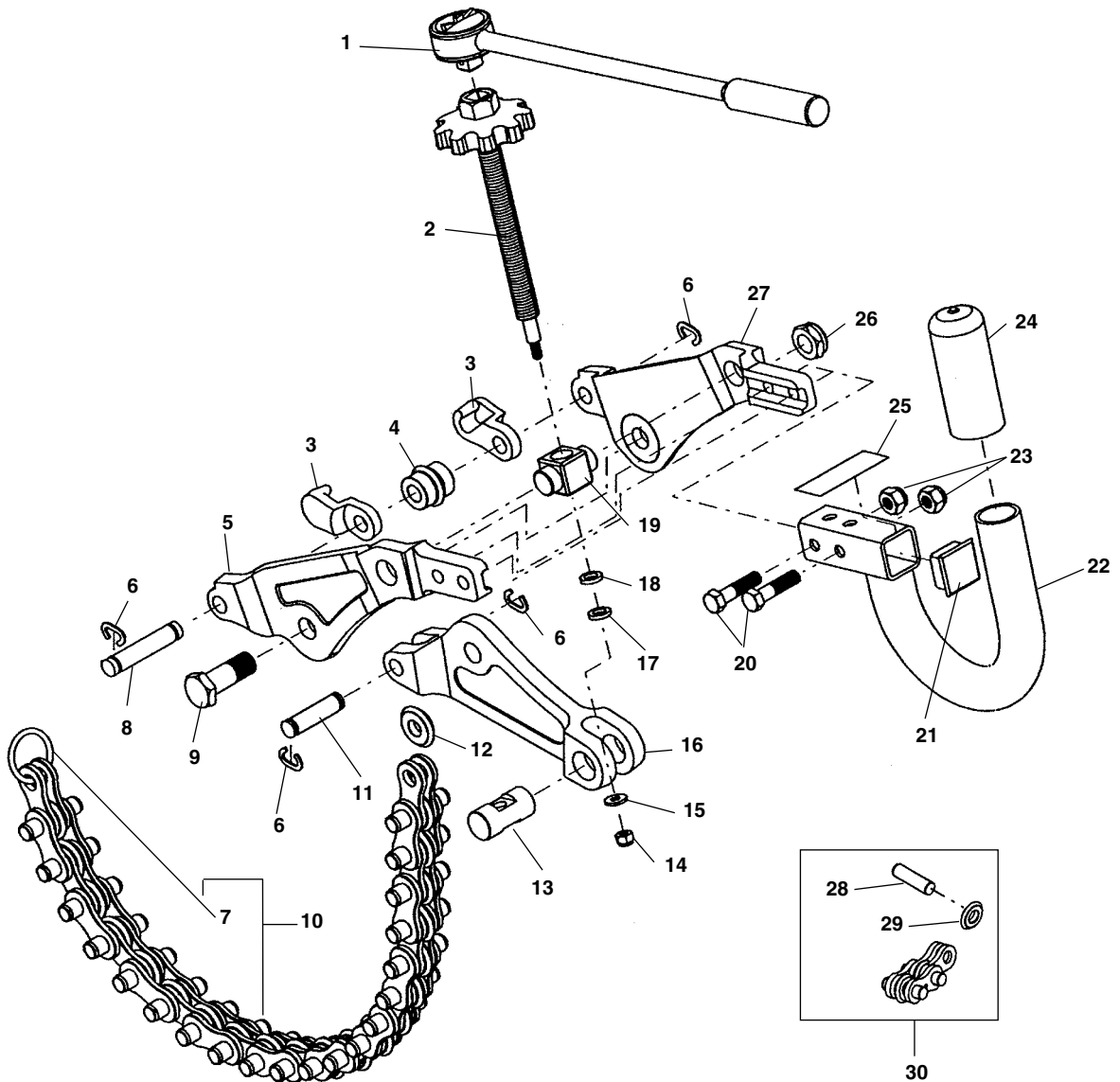

**NOTE: Order parts by Catalog Number only.
DO NOT order by Reference Number.**

Ref. No.	Catalog No.	Description	Ref. No.	Catalog No.	Description
—	69982	226 Soil Pipe Cutter Assembly	16	71812	Center Arm
1	70437	Ratchet	17	71782	Bronze Thrust Washer
2	71772	Feed Screw w/Knob (Includes Nut & Washer)	18	71777	Steel Thrust Washer
3	33605	Hook Assembly	19	71792	Pivot Nut
4	33635	Spacer Wheel	20	83120	Hex Screw 3/8" x 16 x 1 3/4" (2)
5	71797	Left Arm	21	71822	Plug 1.25" SQ.
6	33685	Retaining Ring (4)	22	71817	Handle
7	33675	Chain Ring	23	79985	Stop Nut 3/8" - 16 (2)
8	33650	Pin	24	71832	Handle Grip
9	44312	Hex Head Screw 5/8" - 18 x 1 3/4"	25	72032	Warning Label
10	33670	Chain Assembly	26	71827	Nut 5/8" - 18
11	33645	Pin	27	71787	Right Arm
12	33220	Cutter Wheel	28	33680	Cutter Pin
13	71807	Pivot Pin	29	33220	Cutter Wheel
14	18978	Nut Lock, 5/16" - 18	30	33665	Chain Extension Assembly
15	83890	Nut, 1/2" - 20 (Old Style)			
	18983	Washer, M8			
	27402	Flat Washer 1/4" I.D. (Old Style)			

Soil Pipe Capacity: 2" – 6"
Water Main Capacity: Class 22, 4"

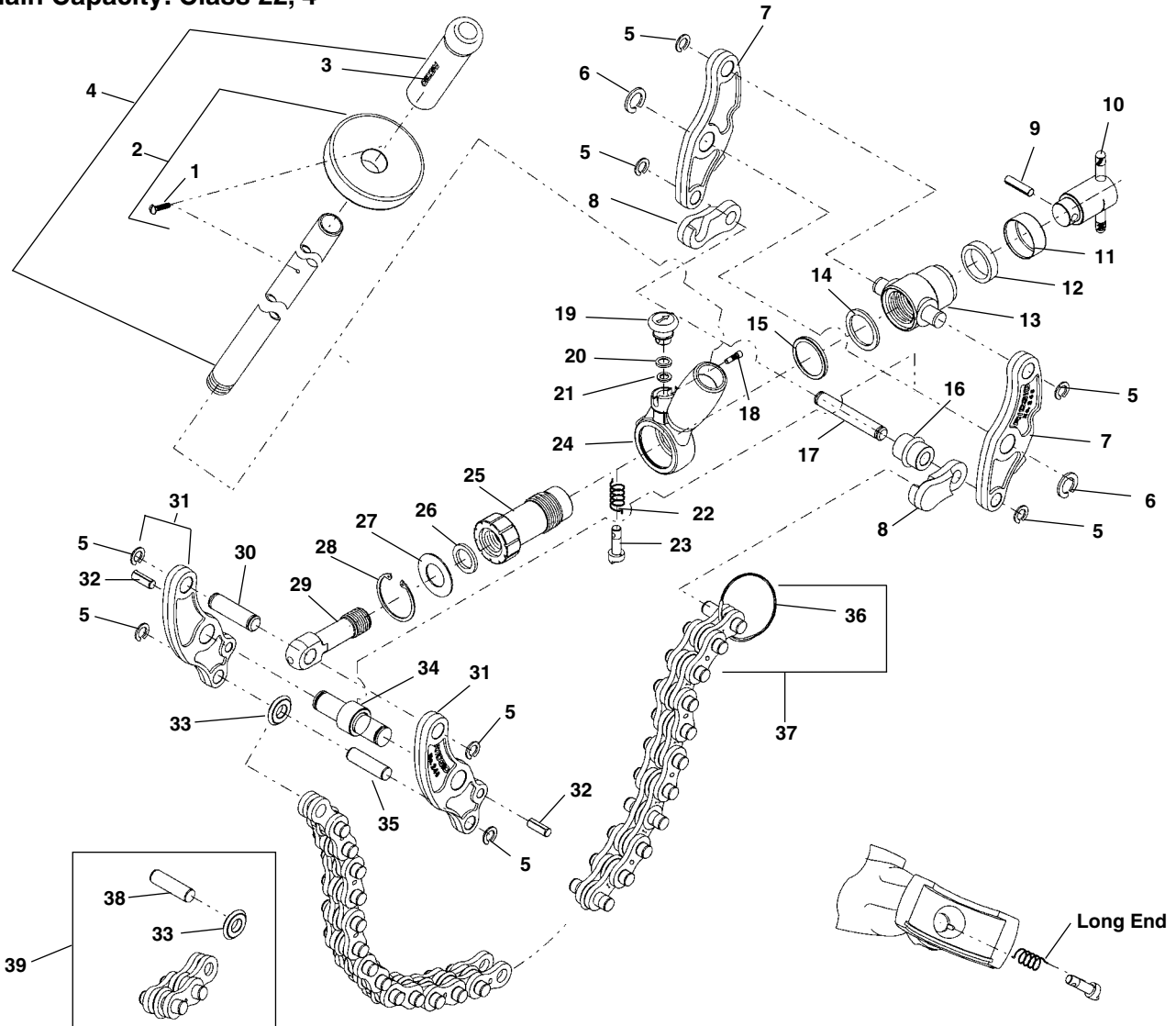

**NOTE: Order parts by Catalog Number only.
 DO NOT order by Reference Number.**

Ref. No.	Catalog No.	Description	Ref. No.	Catalog No.	Description	Ref. No.	Catalog No.	Description
—	32900	246 Soil Pipe Cutter	14	34500	Seal	27	34520	Ratchet Housing Washer
1	46470	Screw	15	34490	Cup	28	33700	Retaining Ring
2	33795	Handle Stop Assembly	16	34440	Spacer Wheel	29	34480	Eyebolt
3	51630	Handgrip	17	34460	Spacer Pin	30	34455	Eyebolt Pin
4	34545	Handle Assembly	18	34450	Pawl Pin	31	33560	Slide Bar (Inside) (2)
5	34550	Retaining Ring (8)	19	38700	Ratchet Knob	32	51502	Spiral Pin (2)
6	34555	Retaining Ring (2)	20	34495	Seal	33	33225	Cutter Wheel
7	33550	Side Bar (Outside) (2)	21	34485	Cup	34	34445	Center Pin
8	33790	Hook Assembly	22	34525	Ratchet Pawl Spring	35	34465	Chain Pin
9	34565	Spring Pin	23	34475	Ratchet Pawl	36	33675	Ring
10	33555	Knob and Handle Assembly	24	99530	Ratchet Housing Assembly	37	34575	Chain Assembly
11	34515	Cup	25	99520	Ratchet Shaft	38	34470	Cutter, Wheel Pin
12	34510	Seal	26	34505	Eyebolt Seal	39	34570	Chain Extension Assembly
13	99525	Trunnion						

* **34570 CHAIN EXTENSION ASSEMBLY**—Includes 33225 Cutter Wheels (2), 34535 Inside Links (2), 34540 Outside Links (2) and 34470 Cutter Pins (2) per section. **34570 CHAIN EXTENSION ASSEMBLY** is completely assembled, except for one cutter wheel and one pin, packed loose. These are needed to make the connection on the existing chain. Each section is approximately 3 inches long. Remove the 33675 Ring at the end of the existing chain...connect the loose wheel and pin to the inner link on the chain. Attach the 33675 Ring to the end of the chain extension.

WARNING: Do not cut soil pipe larger diameter than: Clay – 12" diameter; Cast Iron – 8" diameter

Pipe Capacity: 480 mm

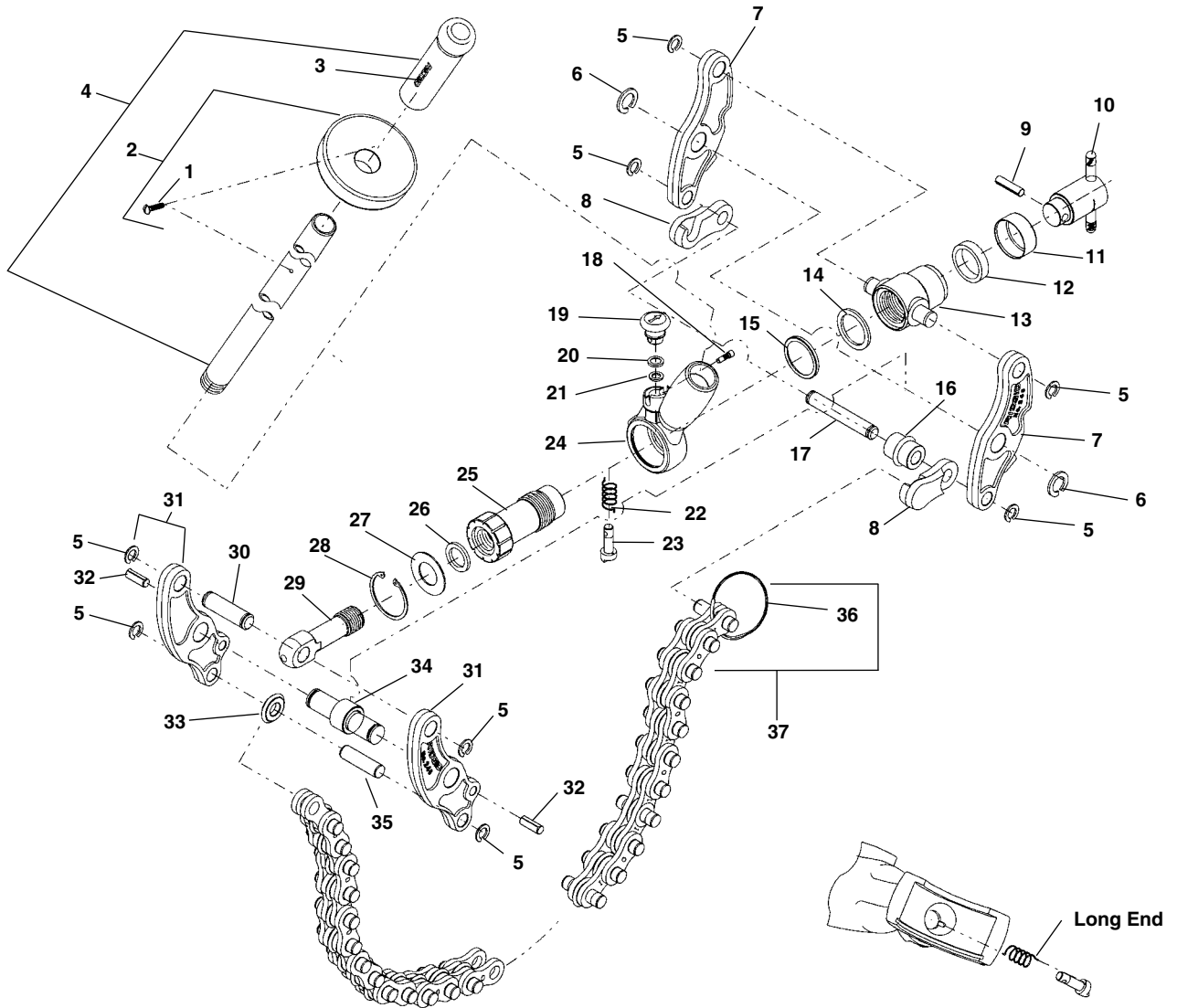

**NOTE: Order parts by Catalog Number only.
DO NOT order by Reference Number.**

Ref. No.	Catalog No.	Description	Ref. No.	Catalog No.	Description	Ref. No.	Catalog No.	Description
—	62797	248 Concrete Pipe Cutter	13	99525	Trunnion	26	34505	Eyebolt Seal
1	46470	Screw	14	34500	Seal	27	34520	Ratchet Housing Washer
2	33795	Handle Stop Assembly	15	34490	Cup	28	33700	Retaining Ring
3	51630	Handgrip	16	63292	Spacer Wheel	29	34480	Eyebolt
4	34545	Handle Assembly	17	34460	Spacer Pin	30	34455	Eyebolt Pin
5	34550	Retaining Ring (8)	18	34450	Pawl Pin	31	33560	Slide Bar (Inside) (2)
6	34555	Retaining Ring (2)	19	38700	Ratchet Knob	32	51502	Spiral Pin (2)
7	33550	Side Bar (Outside) (2)	20	34495	Seal	33	63297	Cutter Wheel
8	63302	Hook Assembly	21	34485	Cup	34	34445	Center Pin
9	34565	Spring Pin	22	34525	Ratchet Pawl Spring	35	34465	Chain Pin
10	63852	Knob and Handle Assembly	23	34475	Ratchet Pawl	36	33675	Ring
11	34515	Cup	24	99530	Ratchet Housing Assembly	37	63287	Chain Assembly
12	34510	Seal	25	99520	Ratchet Shaft			

*** 34570 CHAIN EXTENSION ASSEMBLY—Includes 33225 Cutter Wheels (2), 34535 Inside Links (2), 34540 Outside Links (2) and 34470 Cutter Pins (2) per section. 34570 CHAIN EXTENSION ASSEMBLY is completely assembled, except for one cutter wheel and one pin, packed loose. These are needed to make the connection on the existing chain. Each section is approximately 3 inches long. Remove the 33675 Ring at the end of the existing chain...connect the loose wheel and pin to the inner link on the chain. Attach the 33675 Ring to the end of the chain extension.**

WARNING: Do not cut soil pipe larger diameter than: Clay – 12" diameter; Cast Iron – 8" diameter

Capacity: 2" through 8"

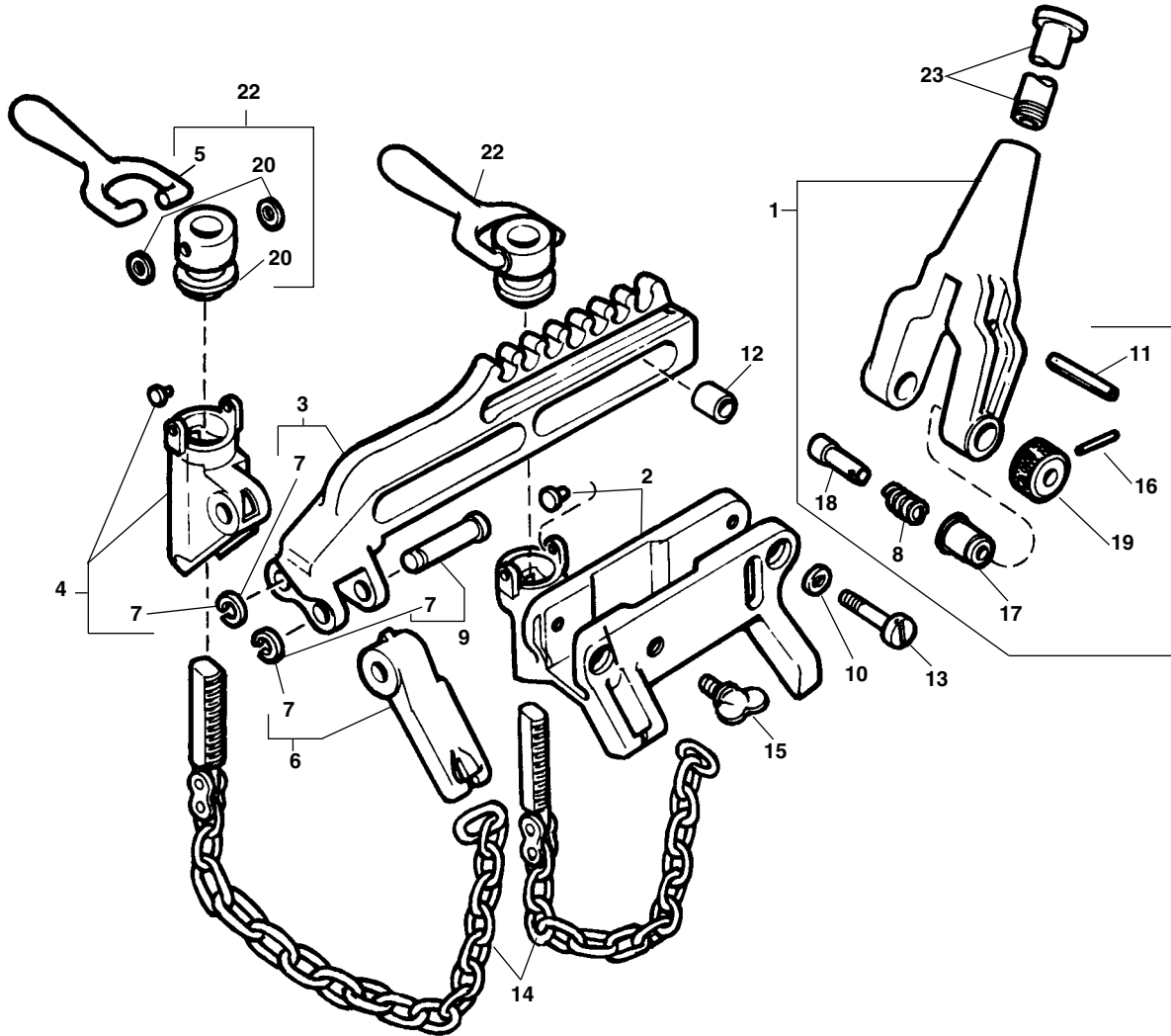

**NOTE: Order parts by Catalog Number only.
DO NOT order by Reference Number.**

Ref. No.	Catalog No.	Description	Ref. No.	Catalog No.	Description
—	32905	228 Soil Pipe Assembly Tool	12	34380	Slide Roller (2)
1	33315	Yoke Assembly	13	34385	Slide Roller Screw (2)
2	33405	Housing w/Pivot Pin	14	34390	Chain and Screw Assembly (2)
3	33410	Slide Assembly	15	34395	Thumb Screw
4	33415	Hinged Jaw Assembly	16	34400	Pin (2)
5	32190	Handle (2)	17	34405	Insert (2)
6	33530	Hinged Hook Assembly	18	34410	Pivot Pin (2)
7	33685	Retaining Ring (2)	19	34415	Knob (2)
8	38695	Coil Spring (2)	20	34430	Washer (4)
9	33775	Hinge Pin Assembly (2)	21	32200	Swivel Nut (2)
10	35530	Lock Washer (2)	22	34795	Handle and Nut Assembly (2)
11	34375	Ratchet Pin	23	47090	Handle

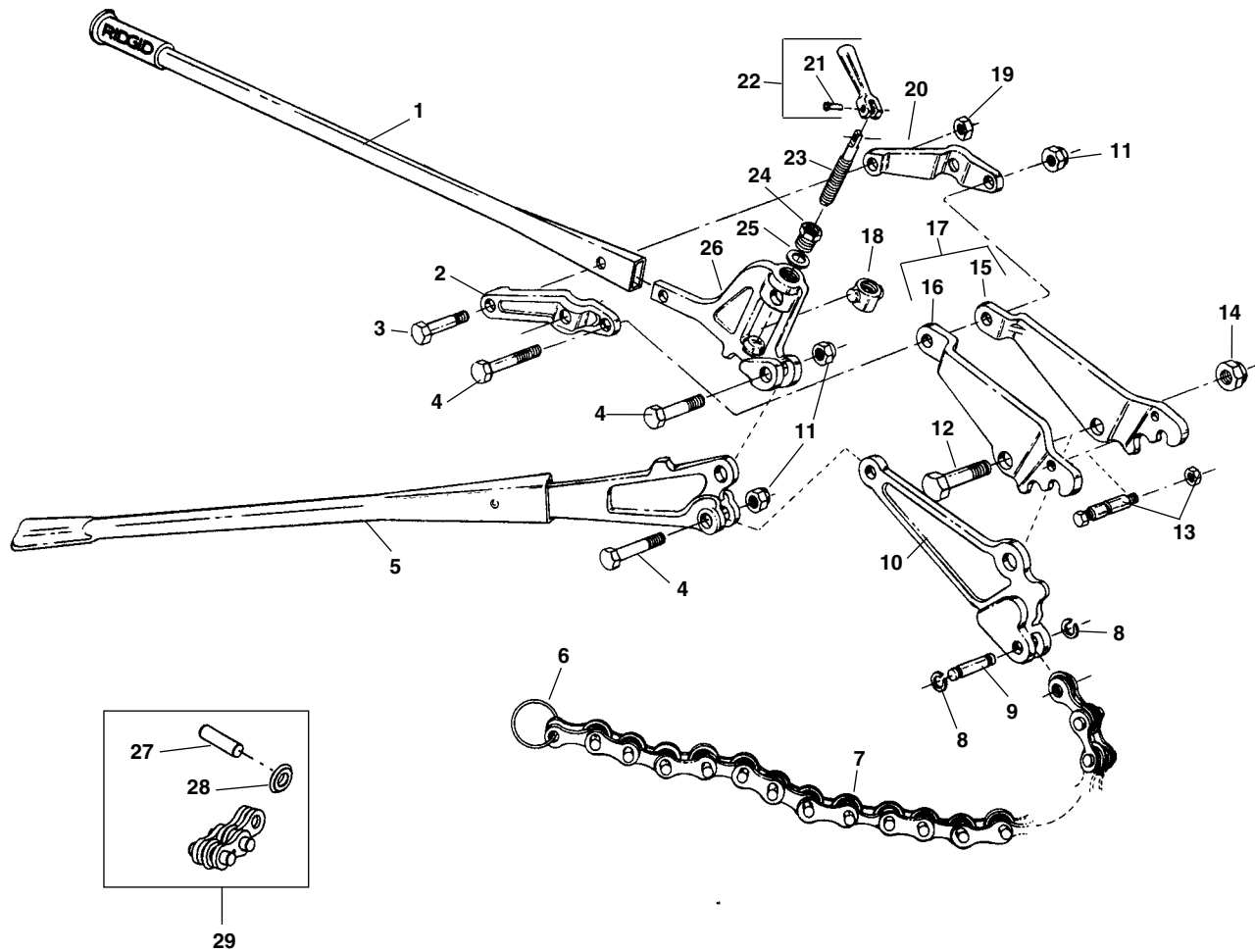

**NOTE: Order parts by Catalog Number only.
DO NOT order by Reference Number.**

Ref. No.	Catalog No.	Description	Ref. No.	Catalog No.	Description
—	43547	266 Soil Pipe Cutter	16	44622	Left Jaw – 266
—	74207	276 Soil Pipe Cutter		74097	Left Jaw – 276
1	44247	Left Handle	17	44297	Top Jaw Assembly – 266
2	44262	Left Handle Bracket	18	44267	Adjusting Block
3	44302	Shoulder Bolt	19	46820	Hex Nut
4	44307	Shoulder Bolt (3)	20	44257	Right Handle Bracket
5	44242	Right Handle	†21	44332	Rivet
6	33675	Ring	22	44277	Adjusting Screw Handle w/Rivet
7	34575	Chain Assembly – 266	23	44272	Adjusting Screw
	33670	Chain Assembly – 276	24	44282	Adjusting Screw Lock Nut
8	34550	E-2655 Retaining Ring (2)	25	44327	Washer
9	33645	Chain Pin	26	44252	Adjusting Screw Housing
10	44292	Bottom Jaw – 266	27	33680	Cutter Pin -276
	74087	Bottom Jaw – 276		34470	Cutter Pin -266
11	44317	Locking Nut (3)	28	33220	Cutter Wheel-276
12	44312	Shoulder Bolt		33225	Cutter Wheel-266
13	44287	Spacer Bolt Assembly – 266	29	33665	Chain Extension Assembly-276
13	74082	Spacer Bolt Assembly – 276		34570	Chain Extension Assembly-266
14	44322	Locking Nut			
15	44627	Right Jaw – 266			
	74092	Right Jaw – 276			

**Hinged Pipe Cutter: No. 424CI/DI, 424S
No. 466C, 466S, 466HWS
No. 468C, 468S, 468HWS
No. 472C, 472S, & 472HWS**

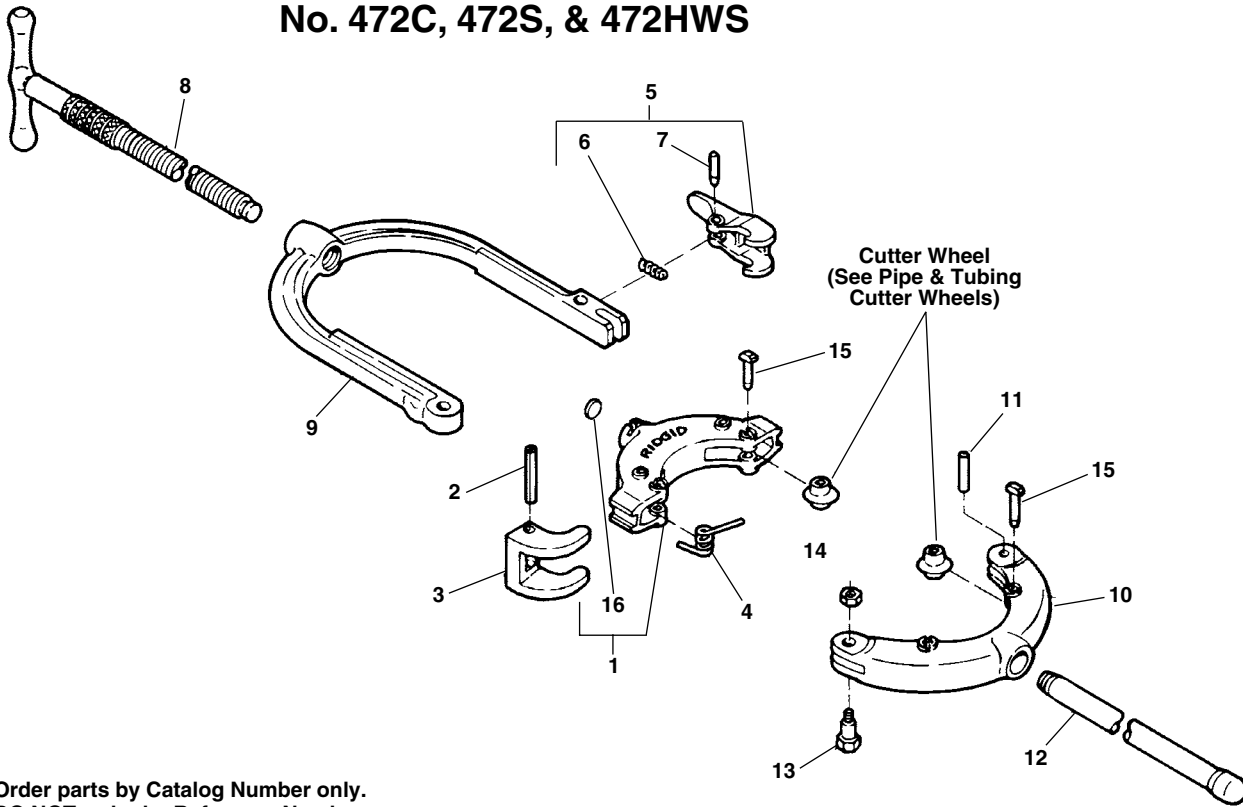

**NOTE: Order parts by Catalog Number only.
DO NOT order by Reference Number.**

	424 2"-4"	466 4"-6"	468 6"-8"	472 8"-12"
Ref. No.	Catalog No.	Catalog No.	Catalog No.	Catalog No.
1 Slide w/Wear Plug	75837	74690	74705	74715
2 Slide Pin (2)	83110	83110	83110	83110
3 Guide (2)	75852	83105	83105	83105
4 Guide Spring (2)	75857	83115	83115	83115
5 Latch Assembly	75887	74695	74695	74695
6 Latch Spring	83130	83130	83130	83130
7 Latch Pin	75867	50307	50307	50307
8 Handle and Screw	75847	83100	83100	83100

	424 2"-4"	466 4"-6"	468 6"-8"	472 8"-12"
Ref. No.	Catalog No.	Catalog No.	Catalog No.	Catalog No.
9 Upper Yoke	75827	83090	83155	83175
10 Lower Yoke	75832	83095	83160	83180
11 Lower Yoke Pin	83125	34375	34375	34375
12 Handle	—	38585	38585	38585
13 Hinge Bolt	83120	83120	83120	83120
14 Stop Nut	79985	79985	79985	79985
15 Wheel Pin (4)	75862	34790	34790	34790
16 Wear Plug	75872	83135	83135	83135

**No. 1-A
No. 2-A
No. 202**

	1-A 1/8"-1 1/4"	2-A 1/8"-2"	202 1/8"-2"
Ref. No.	Catalog No.	Catalog No.	Catalog No.
1 Roll Housing	33765	33765	33400
Wheel Housing	34885	34885	—
F/3 Wheel	—	—	—
2 Roll (2)	34775	34775	34305
3 Roll Pin (2)	34780	34780	34310
4 Wheel Pin	34780	34780	34780
5 Frame	33310	33305	33305
6 Screw Handle	33510	33505	33505

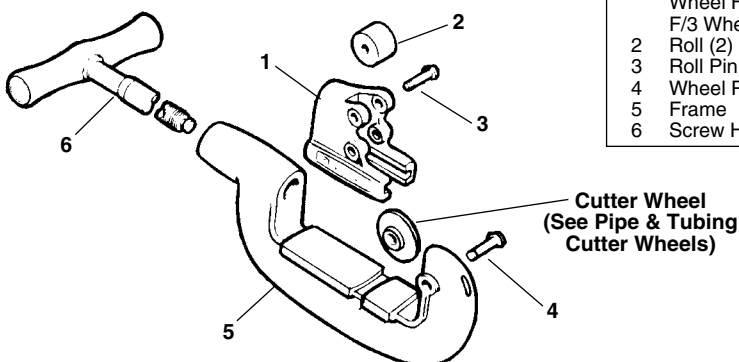

No. 3-S

Capacity: 2", through 3"

No. 4-S

Capacity: 2", through 4"

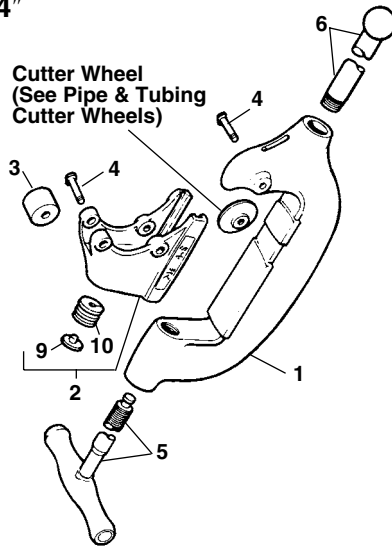

No. 6-S

Capacity: 4" through 6"

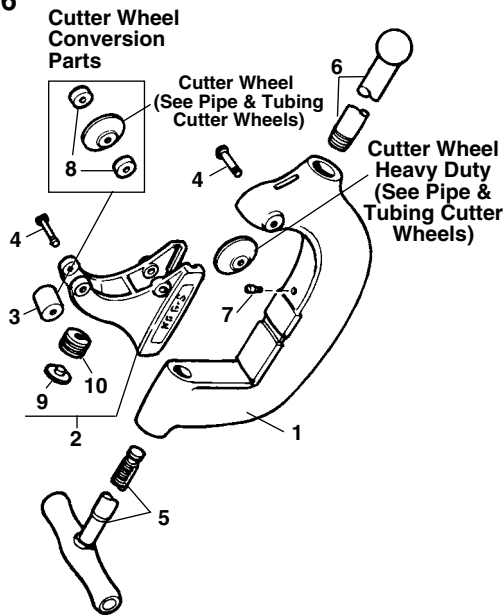

NOTE: Order parts by Catalog Number only.
DO NOT order by Reference Number.

Ref. No.	Description	3-S 1"-3"	4-S 2"-4"	6-S 4"-6"
1	Frame	33285	33280	33275
2	Roll Housing	33390	33385	33300
3	Roll (2)	34785	34785	34785
4	Pin (3)	34790	34790	34790
5	Screw Handle	33515	33515	33515
6	Pipe Handle	35030	35030	35030
7	Stop Screw			34425
8	Wheel Spacer (2)			34855
9	Wear Plug	34320	34320	34320
10	Wear Plug Spring	34315	34315	34315

No. 42-A

Capacity: 1/2" through 2" O.D.

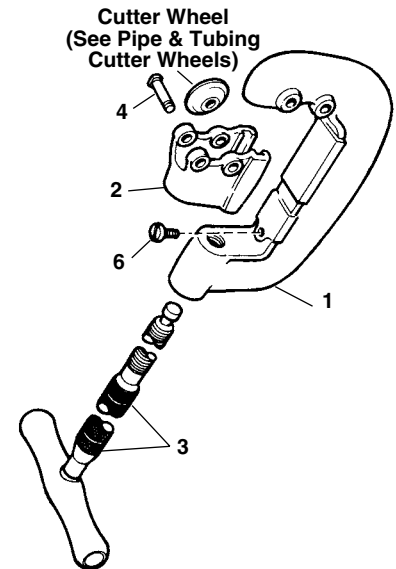

No. 44-S

Capacity: 2 1/2" through 4" O.D.

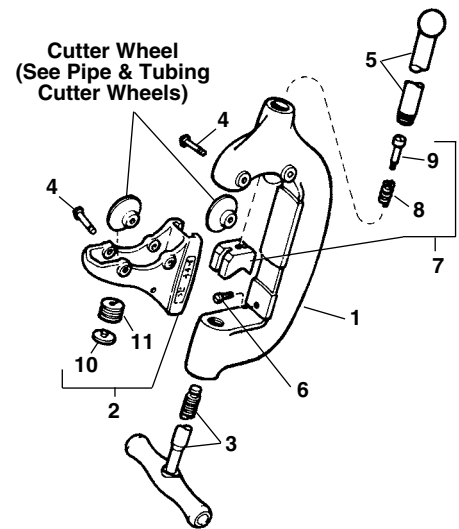

Ref. No.	Description	42-A 1/2"-2"	44-S 2 1/2"-4"
1	Frame	33295	33270
2	Cutter Wheel Housing	33455	33345
3	Screw Handle	33590	33515
4	Wheel Pin (4)	34780	34790
5	Pipe Handle		35030
6	Stop Screw	34425	34425
7	Guide Block Assembly		34840
8	Spring		34850
9	Shoulder Screw		34845
10	Wear Plug		34320
11	Wear Plug Spring		34315

No. 101 Tubing Cutter

**NOTE: Order parts by Catalog Number only.
DO NOT order by Reference Number.**

Ref. No.	Catalog No.	Description
1	42312	Wheel Housing
2	33970	Cutter Wheel Pin and Clip (Incl. Ref. No. 13)
3	33185	E3469 Cutter Wheel
4	33955	Stop Pin
5	34640	Roll (2)
6	42342	Roller Pin (2)
7	34750	Screw w/Washer
8	42337	Knob
9	42327	Retaining Ring
10	42322	Feed Screw
11	42332	Thrust Washer
12	42317	Roll Housing
13	74740	Clip

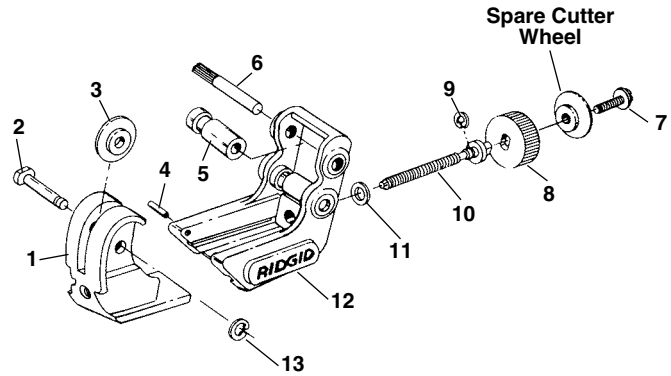

No. 103

Capacity: to 5/8" O.D.

No. 104

Capacity: to 15/16" O.D.

Ref. No.	Description	Capacity	
		No. 103	No. 104
1	Wheel Housing	47342	47332
*	Wheel Housing (Early Style)	33940	33985
2	Cutter Wheel Pin & Clip (Inc. Ref. No. 11)	33970	33970
3	Cutter Wheel	33185	33185
4	Stop Pin	33955	33955
5	Roll (2)	33965	33965
6	Roll Pin (2)	33960	33960
7	Retaining Ring	42327	42327
*	Retaining Ring (Early Style)	33830	33830
8	Feed Screw and Knob Assy.	47322	47317
*	Feed Screw and Knob Assy. (Early Style)	33945	33980
9	Washer	42332	42332
*	Washer (Early Style)	33950	33950
10	Roll Housing	47337	47327
*	Roll Housing (Early Style)	33935	33975
11	Clip	74740	74740

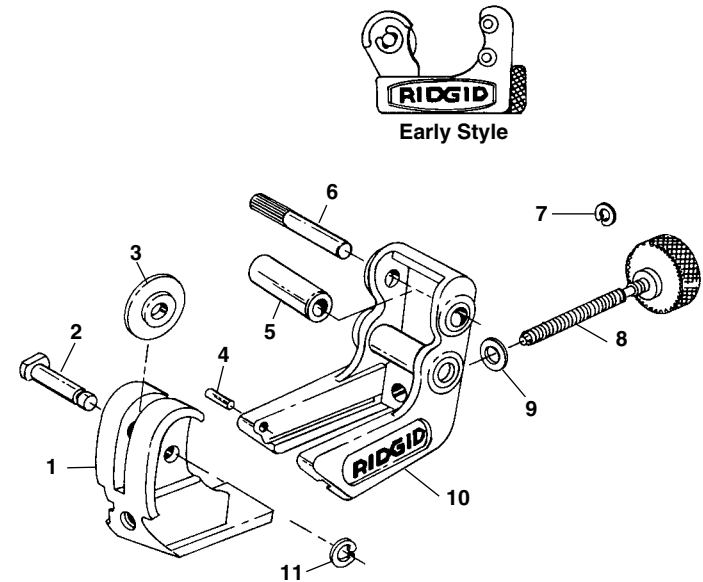

*Early style housings have plated finish

No. 117

Ref. No.	Catalog No.	Description
—	97787	117 Tubing Cutter
1	15348	Feed Screw Assembly
2	42332	Thrust Washer
3	33965	Roll (2)
4	42327	Retaining Clip
5	33185	Cutter Wheel
6	15358	Cutter Wheel Pin w/Clip
7	15363	Spring (2)
8	15368	Cutter Wheel Housing
9	33955	Roll Pin
10	74740	Retaining Clip
11	15353	Frame
12	33960	Pin (2)

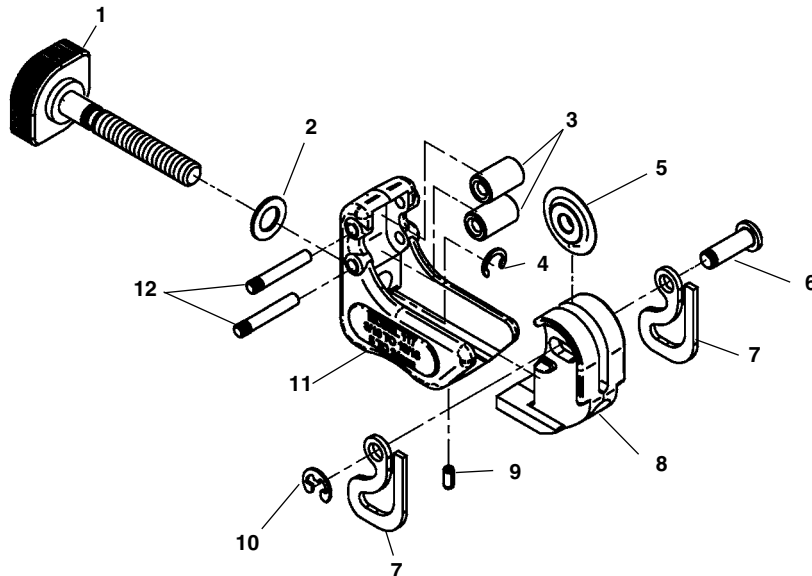

No. 118

NOTE: Order parts by Catalog Number only.
DO NOT order by Reference Number.

Ref. No.	Catalog No.	Description
—	86127	118 Tubing Cutter
1	34750	Knob Retaining Screw
2	33185	Cutter Wheel (2)
3	90862	Knob
4	42322	Feed Screw
5	42332	Thrust Washer
6	90867	Cutter Frame
7	33955	Stop Pin
8	74740	Retaining Ring
9	90857	Cutter Wheel Pin
10	90847	Flat Spring (2)
11	90872	Wheel Housing
12	42327	Retaining Ring
13	42342	Roller Pin (2)
14	34640	Roller (2)

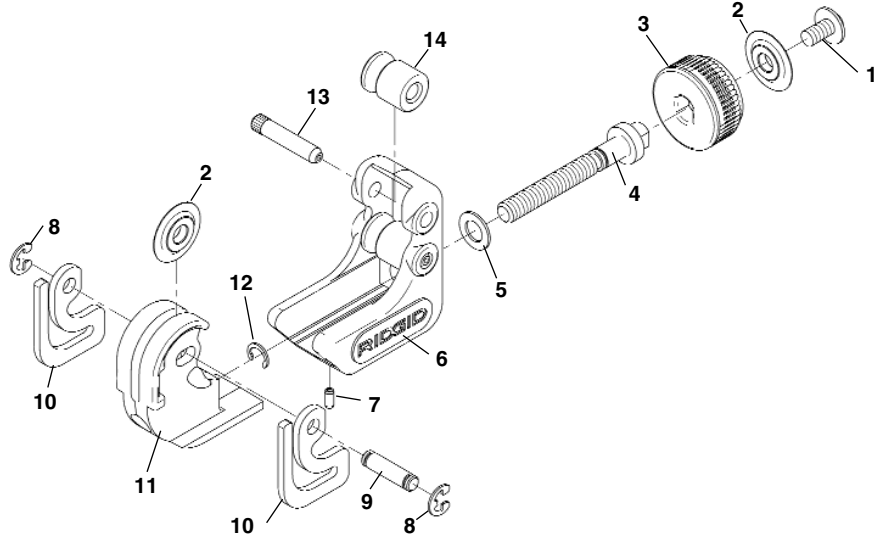

No. 150

Capacity: 1/8" through 1 1/8" O.D.

No. 150L

Capacity: 1/4" through 1 3/8" O.D.

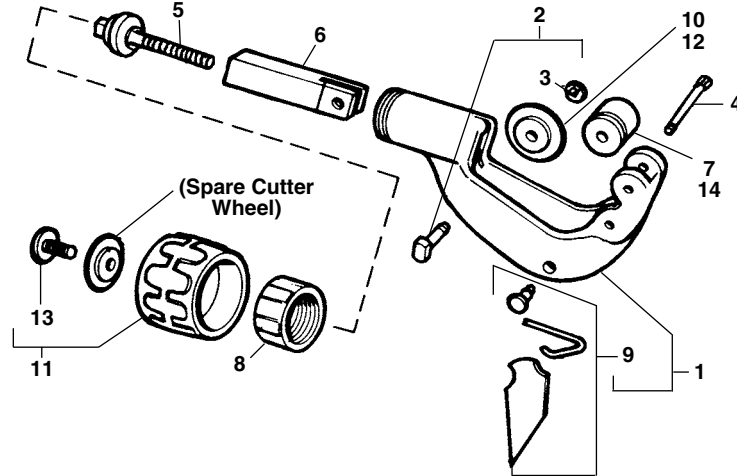

Ref. No.	Description	No. 150	No. 150L/150LS
		Catalog No.	Catalog No.
1	Frame Assembly	33127	92747
2	Pin and Clip	33800	33800
—	Quick Change Pin	22648	22648
3	Clip	74740	74740
4	Roll Pin (2)	33142	33142
5	Feed Screw	33132	92742
6	Slide Bar	33137	92737
7	Roll (2)	34640	34640
8	Bearing Cap	34645	34645
9	Reamer Blade Kit	34650	34650
10	Cutter Wheel (Thin)	33185	33185
11	Knob Assembly	33177	33177
12	Cutter Wheel (H. Duty)	33190	33190
13	Screw	34750	34750
14	Solid Roll (Special)	34765	34765

Tubing: Nos. 151, 152, 153, 154 and 156
Plastic Tubing and Plastic Pipe: Nos. 151-P, 152-P, 153-P, 154-P and 156-P
Capacity: 1/4" through 6 5/8" O.D.

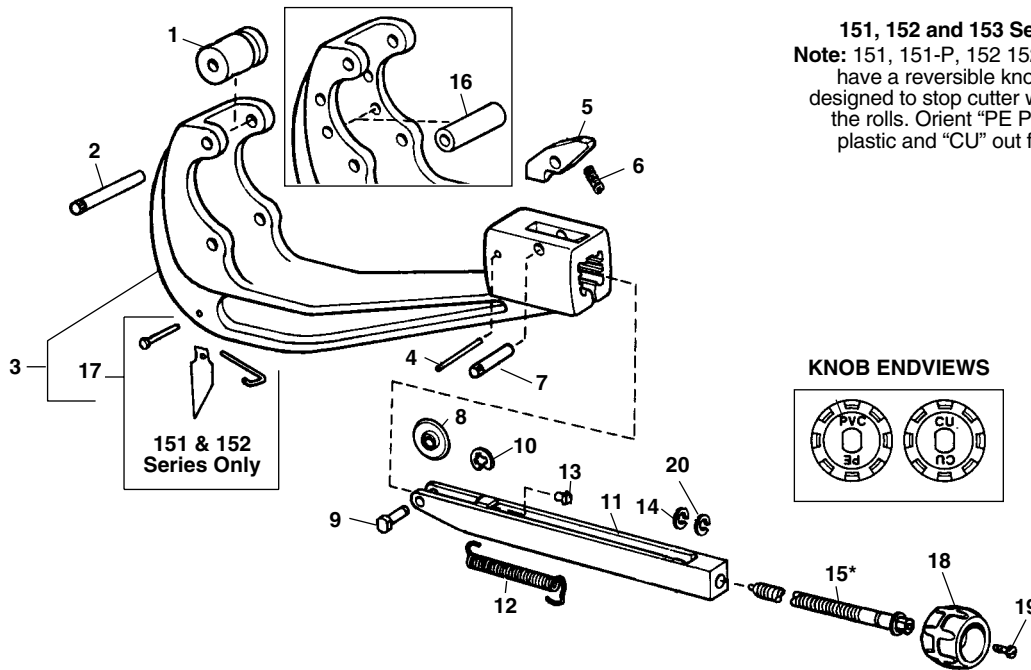

151, 152 and 153 Series Only
Note: 151, 151-P, 152 152-P 153, 153-P have a reversible knob. Knob is designed to stop cutter wheel short of the rolls. Orient "PE PVC" out for plastic and "CU" out for copper.

NOTE: Order parts by Catalog Number only.
DO NOT order by Reference Number.

Ref. No.	151 1/4"-1 5/8" O.D.	152 1/4"-2 5/8" O.D.	153 1 1/4"-3 1/2" O.D.	154 1 1/2"-4 1/4" O.D.	156 4"-6 5/8" O.D.
1	32097 (2)	34670 (2)	34670 (2)	32102 (2)	32102 (2)
2	32107 (2)	32112 (4)	32112 (4)	32117 (2)	32117 (2)
3	32017	32022	32962	32027	32032
4	33122	32152	32152	32157	32157
5	51307	51312	51312	51312	51312
6	34190	34190	34190	34190	34190
7	41545	78425	78425	51302	51302
8	33185	33185	33185	33170	33170
9	32142	32142	32142	32147	32147
—	21533	21533	21533	22643	22643
10	74740	74740	74740	34175	34175
11	32037	32042	32042	32047	32047
12	32087	32092	32092	32092	32092
13	41577	32082	32082	32082	32082
14	32162	32167	32167	32167	32167
15*	41847	32057	32057	22383	22383
16	—	34665 (2)	—	—	—
17	32172	32172	—	—	—
18	33177	33182	33182	33182	33182
19	34750	34750	34750	34750	34750
20	—	—	—	47137	47137
Description	151-P	152-P	153-P	154-P	156-P
8	1/4"-1" Nom. 74720	1/4"-2" Nom. 74720	1 1/4"-3 1/2" Nom. 74720	1 1/2"-4" Nom. 74730	4"-6" Nom. 74735
Description	—	152-PVC 1/4"-2" Nom. 33195	—	—	—

NOTE: 1. All parts for the P-Series are the same as the Quick-Acting except for those parts listed.
 2. 151-P and 152-P can cut thin wall PVC and flexible plastic when using the 33200 Cutter Wheel.
 * 151 Feed Screw also includes Ref. 13 Bearing.

No. 138 Plastic Pipe & Tube Cutter

Capacity: 1/8" - 1 1/2" O.D. (3mm - 38mm)

NOTE: Order parts by Catalog Number only.
DO NOT order by Reference Number.

Ref. No.	Catalog No.	Description
—	91125	138 Plastic Pipe Cutter
1	92200	Screw (3)
2	92160	Housing (Right Side)
3	92180	Pin
4	92175	Arm (2)
5	74740	Retaining Ring
6	92210	Spring Kit
7	92165	Handle
8	92190	Pin
9	92155	Housing (Left Side)
10	92205	Shoulder Screw
11	92195	Pin
12	92170	Blade
13	92185	Latch
14	64657	Latch Spring

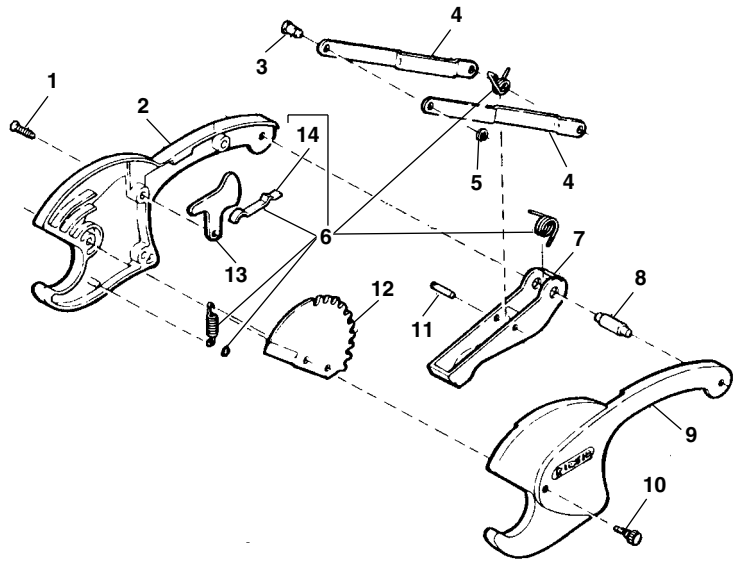

Caution: DO NOT cut metal braid reinforced hose, metal pipe or tubing, wire cable or wood. These materials will damage the blade.

No. 1493 Plastic Pipe Cutter

Capacity: 1/8" - 2 3/8" O.D. (3mm - 60mm)

Ref. No.	Catalog No.	Description
—	12831	1493 Plastic Pipe Cutter
1	22086	Blade
2	47527	Ratchet & Link Assembly
3	47522	Spring Set

* - Included in Ratchet/Link Assembly

Caution: DO NOT cut metal braid reinforced hose, metal pipe or tubing, wire cable or wood. These materials will damage the blade.

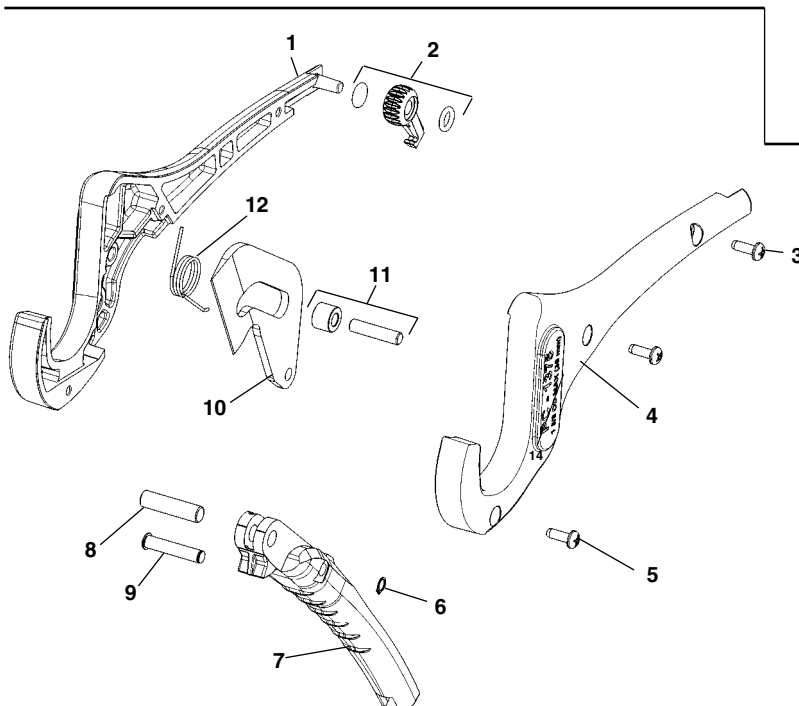
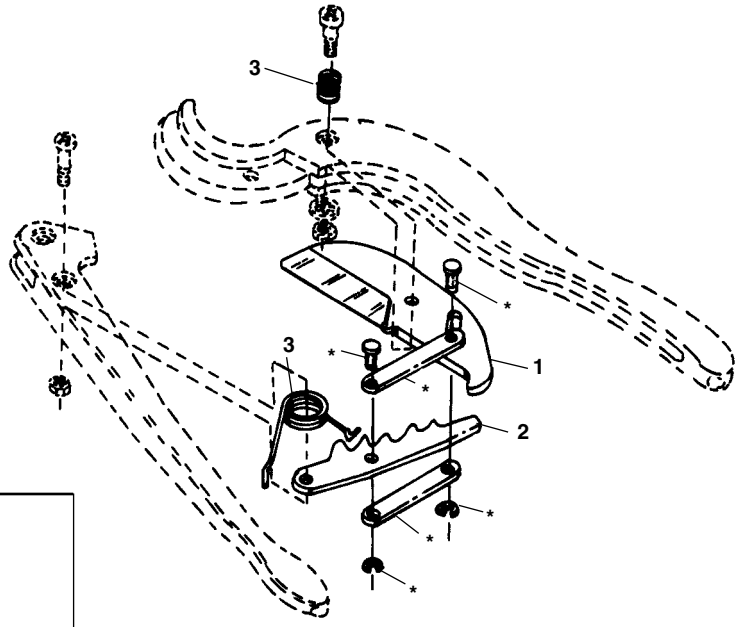

PC-1375 Plastic Pipe Cutter

Ref. No.	Catalog No.	Description
1	25538	R.H. Handle
2	25543	Latch Assembly
3	25548	Screws (3)
4	25563	L.H. Handle
5	25568	Screws (3)
6	25553	Retaining Rings (3)
7	25573	Lower Handle
8	25578	Blade Pin
9	25583	Handle Pin
10	25588	Blade
11	25598	Roller & Pin
12	25593	Spring

Nos. 205 and 205-P (Plastic)

Capacity: 1/4" through 2 3/8"

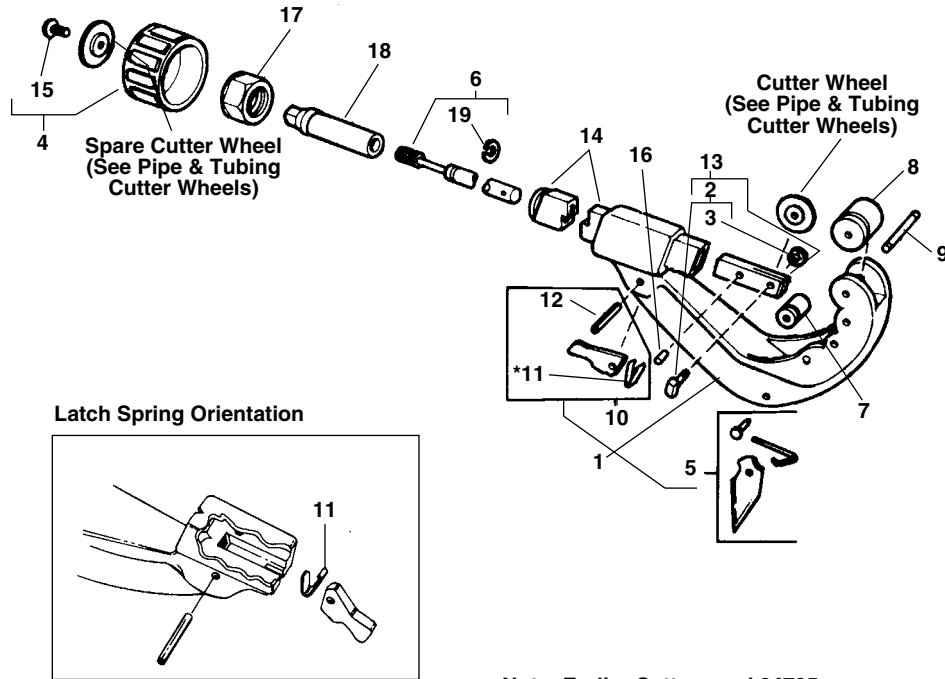

Note: Earlier Cutter used 34735 Wheel Screw and 45175 Washer. Update by using 34700

NOTE: Order parts by Catalog Number only. DO NOT order by Reference Number.

Ref. No.	Catalog No.	Description
1	33395	Frame Assembly
2	33805	Pin and Clip
3	74740	Clip
4	34625	Knob Assembly
5	34650	Reamer Blade Assembly
6	34660	Feed Screw Assembly
7	34665	Small Roll (2)
8	34670	Large Roll (2)
9	32112	Roll Pin (4)
10	34680	Latch Assembly
11	34685	Latch Spring
12	34690	Latch Pin
13	34700	Slide Bar Assembly
14	34705	Ratchet Shaft
15	34750	Screw with Washer
16	34720	Pin
17	34725	Bearing Cap
18	34730	Feed Screw Nut
19	34745	Snap Ring

No. 10

Capacity: 1/8" through 1" O.D.

No. 15

Capacity: 3/16" through 1 1/8" O.D.

No. 20

Capacity: 5/8" through 2 1/8" O.D.

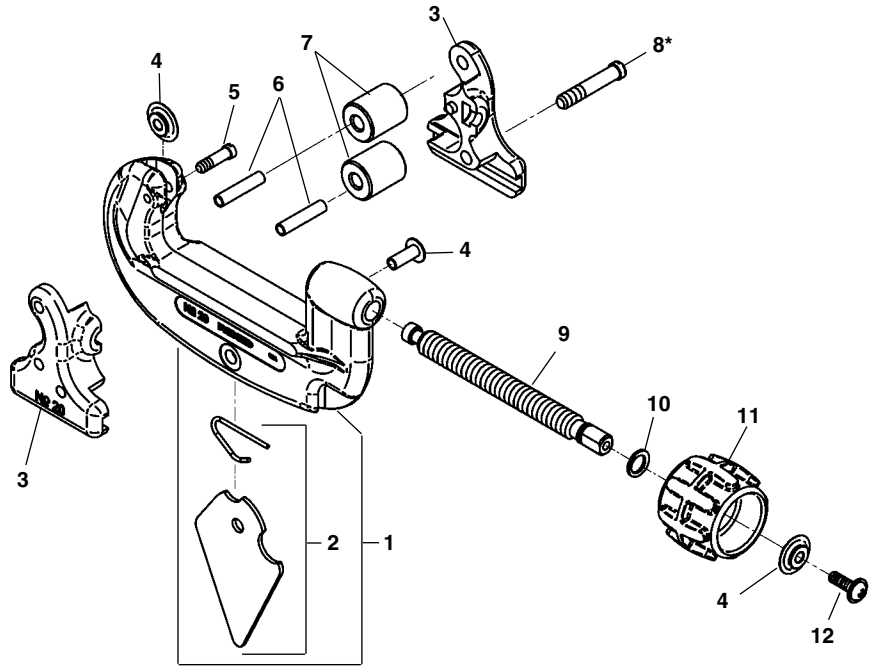

**NOTE: Order parts by Catalog Number only.
DO NOT order by Reference Number.**

Ref. No.	Description	10	15	20
		1/8"-1"	3/16"-1 1/8"	5/8"-2 1/8"
Ref. No.	Description	Catalog No.	Catalog No.	Catalog No.
1	Frame Assembly	34605	34600	33575
2	Reamer Blade, Spring & Pin	34330	34335	34340
3	Roll Housing	33760	34610	33580
4	Cutter Wheel (Thin)	33160	33160	33160
	Cutter Wheel (Heavy-Duty)	33165	33165	33165
5	Wheel Screw	34325	34325	34345
6	Roll Pin	34860	*	*
7	Roll	34830	34805	34825
8*	Roll Housing Screw	34300	34615	34620
9	Feed Screw	11308	11323	11313
10	Retaining Ring	11298	11303	11303
11	Knob w/Screw	33177	33182	33182
12	Screw	61097	61097	61097

*Three Roll Housing Screws (Ref. No. 8) used in place of Roll Pins.

No. 30

Capacity: 1" through 3" O.D.

Ref. No.	Catalog No.	Description
1	33375	Frame Assembly
2	34360	Wheel Screw
3	34420	Stop Screw
4	33932	Roll Pin
5	34365	Screw Handle
6	33520	Roll Housing
7	34370	Roll
8	33170	Cutter Wheel (Thin)
	33175	Cutter Wheel (Heavy-Duty)

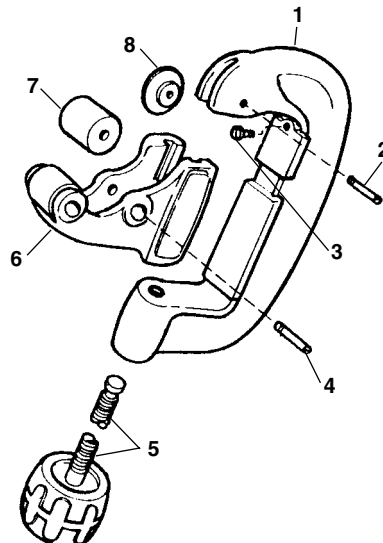

No. 15-SI

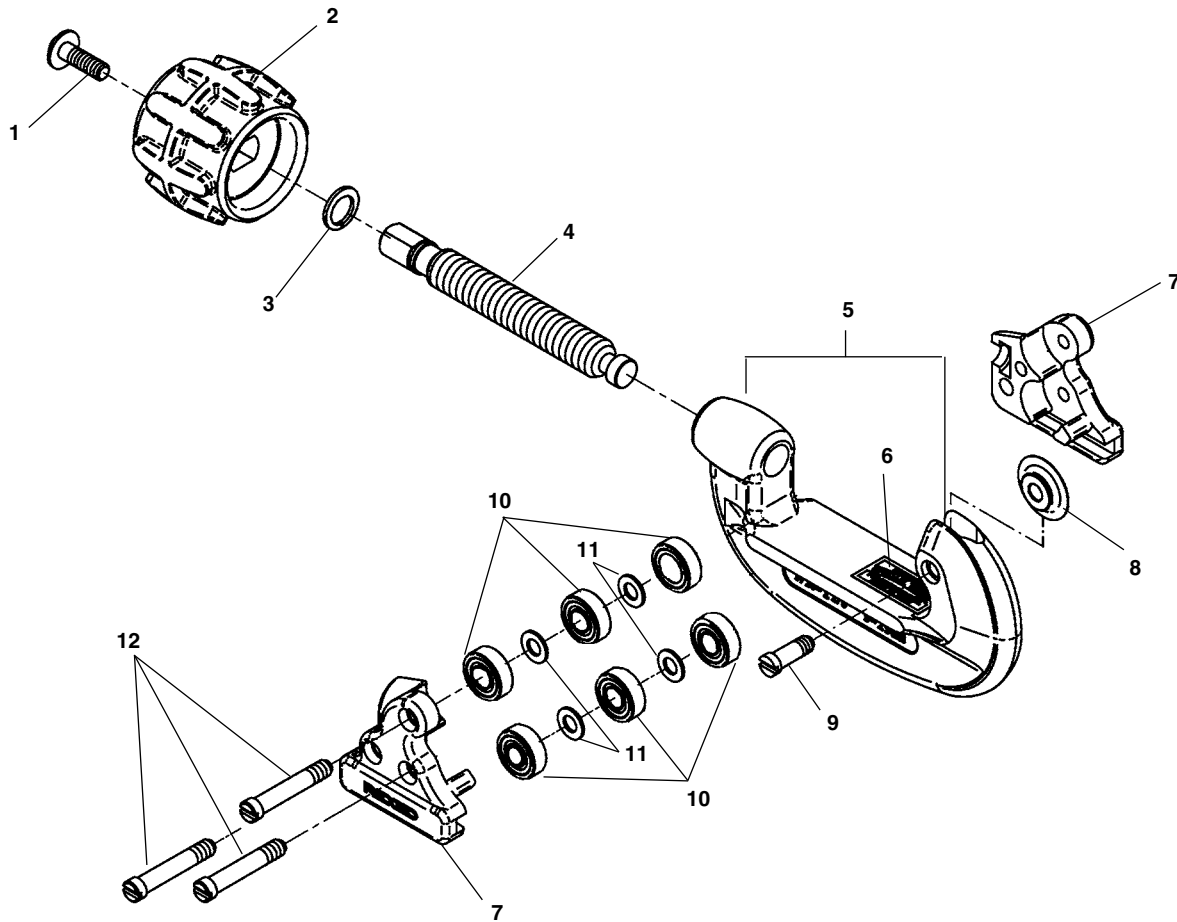

**NOTE: Order parts by Catalog Number only.
DO NOT order by Reference Number.**

Ref. No.	Catalog No.	Description
—	97212	15-SI Tubing Cutter
1	34750	Screw 10 - 32 x 3/8"
2	33182	Knob
3	11303	Retaining Ring
4	11323	Feedscrew
5	97797	Frame
6	97817	Decal
7	97977	Roll Housing Assembly
8	96397	E-1525 Cutter Wheel
9	34325	Cutter Wheel Screw
10	97802	Roller Bearing (6)
11	97807	Spacer Washer (4)
12	34615	Roll Housing Screw (3)

No. 102 Copper Tubing Cutter

Capacity: 1/2" through 3/4" I.D.

**NOTE: Order parts by Catalog Number only.
DO NOT order by Reference Number.**

Ref. No.	Catalog No.	Description
—	32970	102 Tubing Cutter
1	32735	Cutter Bar
2	33685	Retaining Ring (2)
3	46015	5/32" Socket Head Wrench
4	33780	3/4" Guide Bushing
5	33785	Set Screw
6	33810	Feed Rod
7	33815	Knob
8	33820	Cut-Off Tool
9	33825	Lock Screw
10	33835	Finger Guard
11	33840	Nylon Washer (2)
12	33845	Stop Collar Assembly
13	33850	Thumb Screw
14	33855	Ratchet Assembly
15	33860	Handgrip
16	33830	Clip (2)

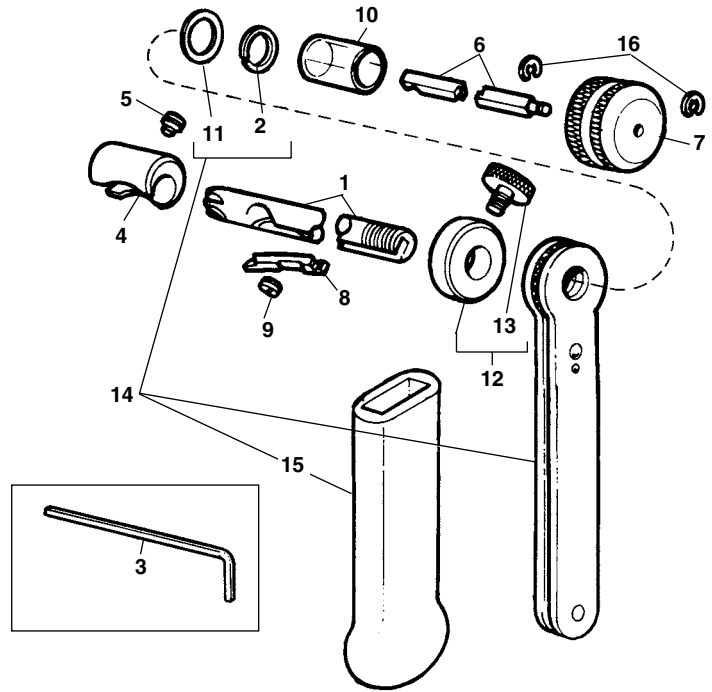

No. 106 Copper and Plastic Tubing Cutter

Capacity: 2" through 3" I.D.

Ref. No.	Catalog No.	Description
—	33005	106 Tubing Cutter
1	33475	Cut Off Gage Slide
2	33865	Cut Off Gage
3	33870	2" Roll Cage
4	33875	3" Roll Cage
5	33880	Feed Screw w/Knob
6	33885	Gage Rod
7	87855	Thumb Screw
8	33895	Sleeve
9	33900	Pivot Bar
10	33905	Thumb Screw
11	33910	Wheel Screw
12	33915	Roll (4)
13	33920	Roll Pin (4)
14	33925	Pivot Pin (2)
15	33170	Cutter Wheel
16	33180	Cutter Wheel (for plastic)

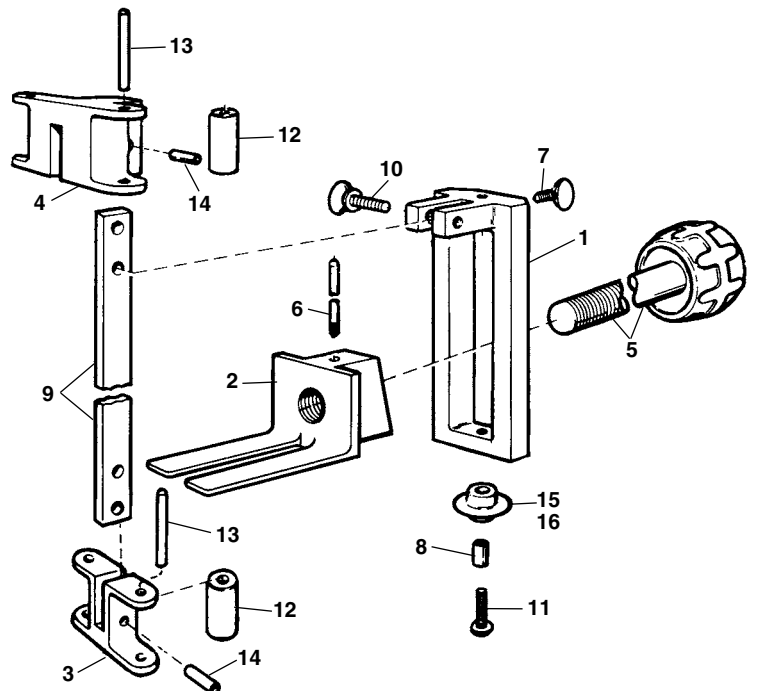

No. 108 Internal Tubing Cutter

Capacity: 1 1/4" through 2" I.D.

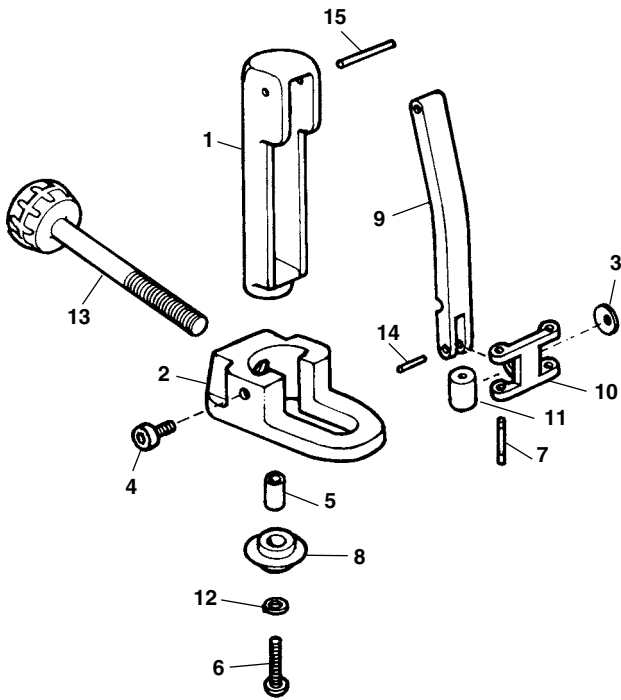

**NOTE: Order parts by Catalog Number only.
DO NOT order by Reference Number.**

Ref. No.	Catalog No.	Description
—	83240	108 Tubing Cutter
1	83245	Housing
2	83250	Guide
3	83280	Washer
4	87855	Cap Screw
5	33895	Sleeve
6	33910	Screw
7	33960	Pin (2)
8	33170	Cutter Wheel
9	83255	Roller Pivot Bar
10	83260	Roller Cage
11	83265	Roller (2)
12	83275	Washer
13	83270	Feed Screw
14	34720	Roll Pin
15	41500	Roll Pin

No. 109 & 109-P Internal Tubing Cutter

Capacity: 2 1/2" through 4" I.D.

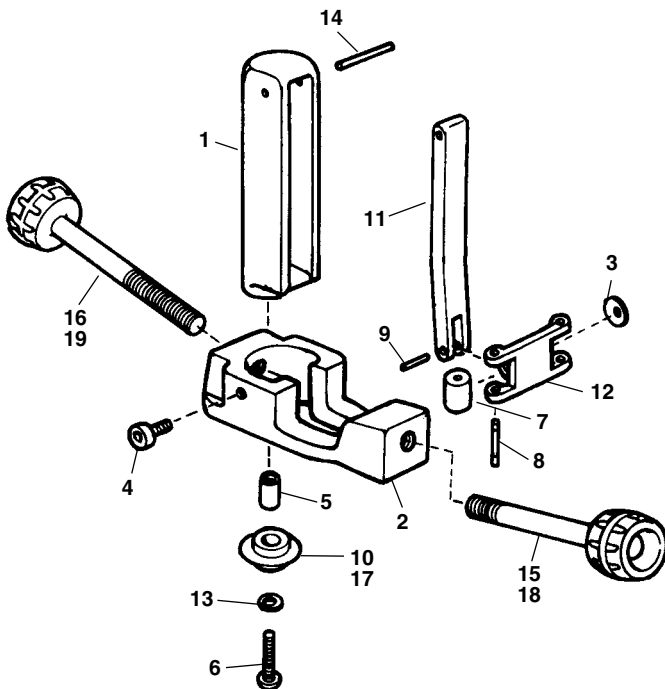

Ref. No.	Catalog No.	Description
—	83290	109 Tubing Cutter
—	83295	109-P Tubing Cutter
1	83300	Housing
2	83305	Guide
3	92150	Washer
4	87855	Cap Screw
5	33895	Sleeve
6	33910	Screw
7	33915	Roller (2)
8	33920	Pin (2)
9	32475	Roll Pin
10	33170	Cutter Wheel (Copper)
11	83310	Roller Pivot Bar
12	83315	Roller Cage
13	83275	Washer
14	83325	Roll Pin
15	83320	Handle (for Tubing)
16	83270	Feed Screw (for Tubing)
17	33180	Cutter Wheel (Plastic)
18	87460	Handle (for Plastic)
19	87455	Feed Screw (for Plastic)

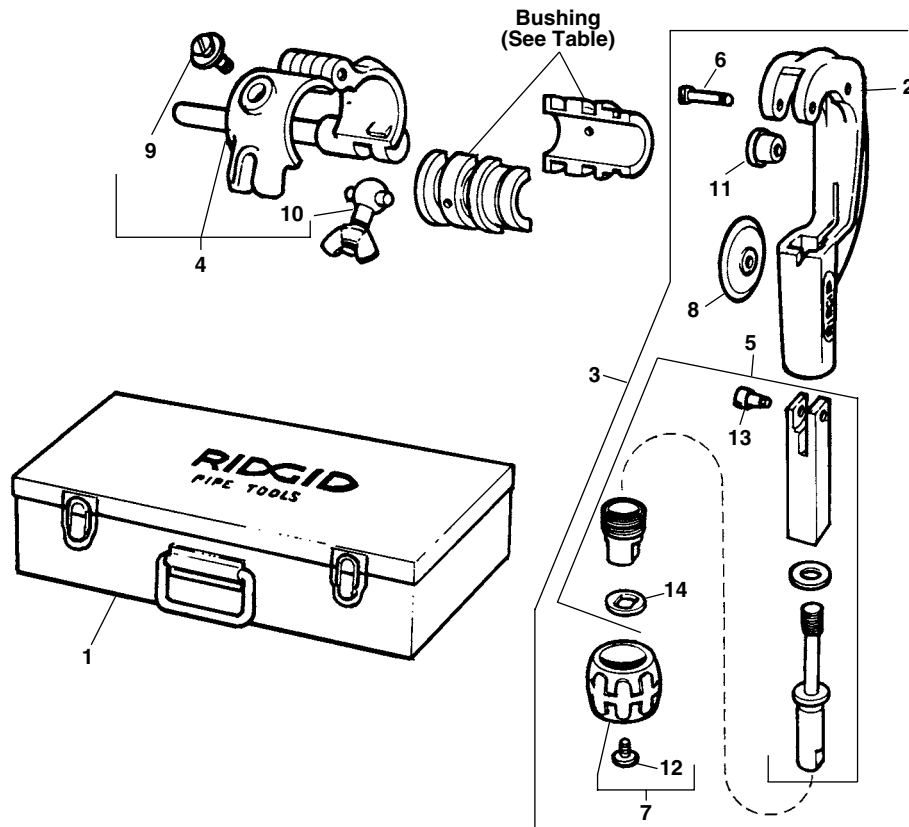

Catalog No.	STANDARD AVAILABLE BUSHING SIZES			
	Bushing No.	Code Name	AWG or Cir. Mils	No. of Strands
54975	E-5900	Raven	1/0	6/1
54440	E-5761	Quail	2/0	6/1
54445	E-5762	Pigeon	3/0	6/1
54450	E-5763	Penguin	4/0	6/1
54465	E-5766	Partridge	266800	26/7
54480	E-5769	Linnet	336400	26/7
54490	E-5771	Chickadee	397500	18/1
54500	E-5773	Ibis	397500	26/7
54505	E-5774	Lark	397500	30/7
54515	E-5776	Flicker	477000	24/7
54520	E-5777	Hawk	477000	26/7
54535	E-5780	Parakeet	556500	24/7
54540	E-5781	Dove	556500	26/7
54580	E-5789	Grosbeak	636000	26/7
54625	E-5800	Drake	795000	26/7
54630	E-5801	Mallard	795000	30/19
54650	E-5805	Rail	954000	45/7
54655	E-5806	Cardinal	954000	54/7
54695	E-5815	Pheasant	1272000	54/19

Other sizes from 8 AWG through 1,780,000 C.M. on request.

NOTE: Order parts by Catalog Number only. DO NOT order by Reference Number.

Ref. No.	Catalog No.	Description
1	54140	Carrying Case
2	54145	Cutter Frame
3	54150	Cutter Assembly (Complete)
4	54160	Bushing Holder Assembly (complete)
5	54165	Bar & Feed Screw Assembly
6	34355	Roll Pin (2)
7	34625	Knob Assembly
8	54270	Cutter Wheel
9	54275	Screw and Fastener (2)
10	54280	Pin, Screw & Wing Nut Assembly
11	54285	Roll (2)
12	34750	Screw with Washer
13	54305	Wheel Screw
14	54310	Washer

Nos. 21 through 27

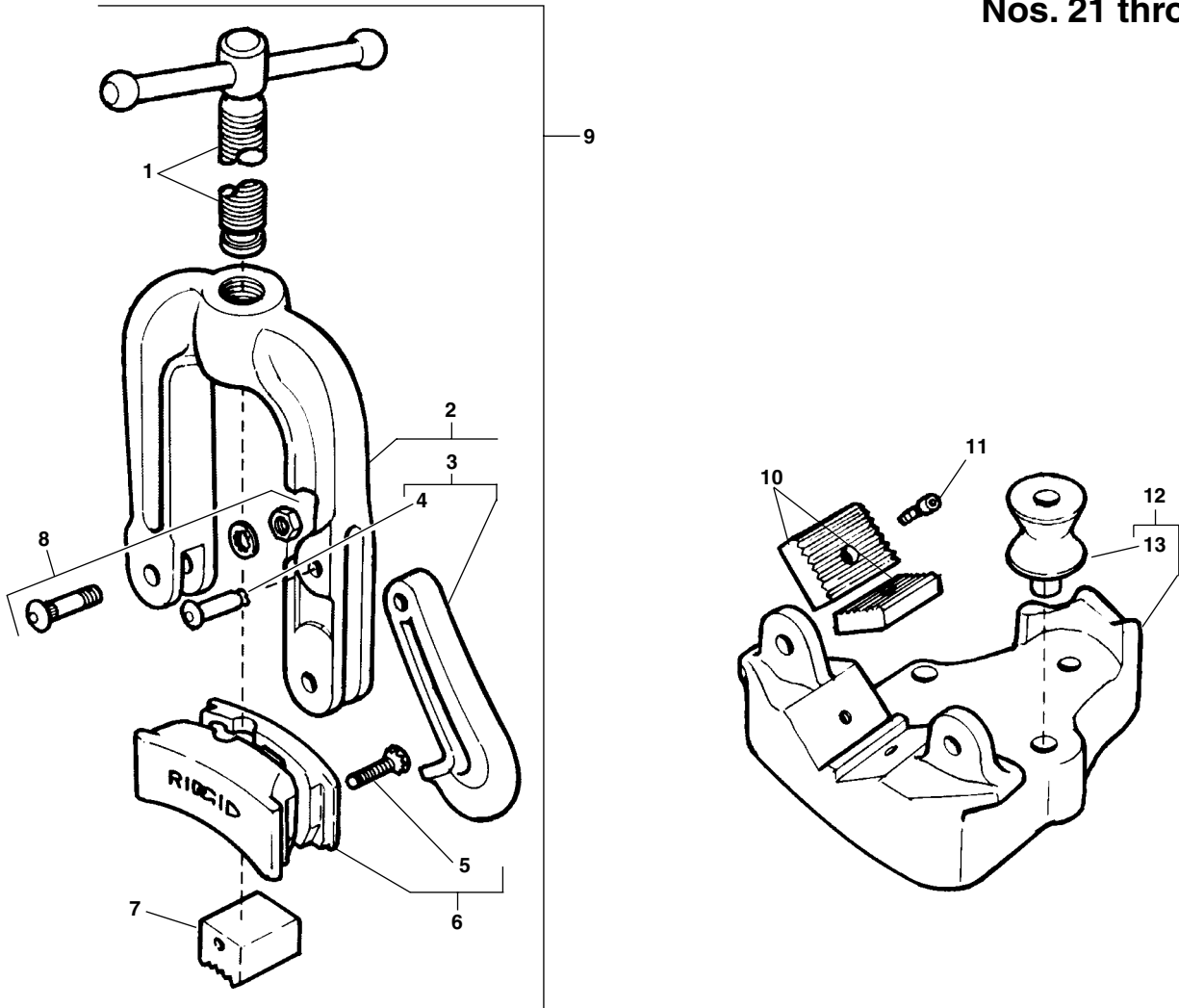

**NOTE: Order parts by Catalog Number only.
DO NOT order by Reference Number.**

	21 1/8"-2"	22 1/8"-2 1/2"	23 1/8"-3"	25 1/8"-4"	27 1/8"-6"
Ref. No. Description	Catalog No.	Catalog No.	Catalog No.	Catalog No.	Catalog No.
1 Feed Screw	40355	40390	40440	40535	40645
2 Yoke & Hook Assembly	40310	40370	40425	40515	40620
3 Hook Assembly	40320	40380	40435	40525	40630
4 Hinge Pin	40340	40415	40470	40555	40670
5 Jaw Clamp Screw with Washer (2)	40345	40385	40385	40530	40635
6 Jaw Clamp Assembly	40360	40395	40445	40540	40650
7 Upper Jaw	40335	40400	40455	40545	40590
8 Hinge Bolt, Washer and Nut	40325	40410	40465	40560	40665
9 Yoke Assembly	40315	40375	40430	40520	40625
10 Lower Jaw (1 Set)	32100	40405	40460	40550	40660
11 Lower Jaw Screw (2)	32205	32205	32205	32205	32270
12 Base Assembly	40305	40365	40420	40510	40615
13 Spool	40330	40330	40450	40450	40655

**Nos. BC-210, BC-410, BC-510, BC-610, BC-810,
BC-210-P & BC-410-P**

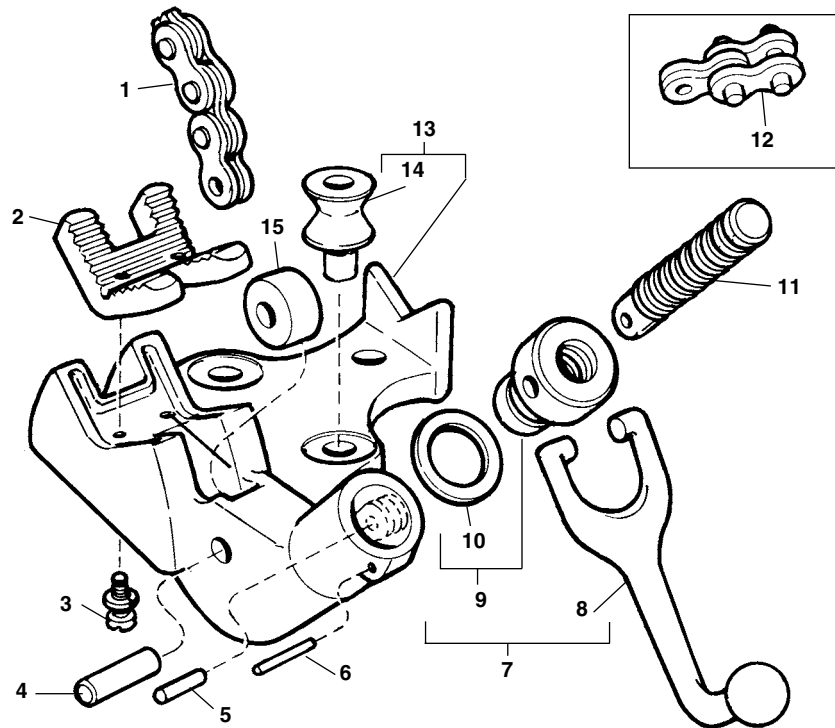

**NOTE: Order parts by Catalog Number only.
DO NOT order by Reference Number.**

	BC-210/BC-210P 1/8"-2 1/2"	BC-410/BC-410P 1/8"-4"	BC-510 1/8"-5"	BC-610 1/4"-6"	BC-810 1/2"-8"
Ref. No.	Catalog No.	Catalog No.	Catalog No.	Catalog No.	Catalog No.
1 Chain Assembly	41005	41055	41075	41130	41155
2 Jaw	40985	41020	41020	41085	41140
Jaw f/Plastic Pipe	41275	41280	41280	—	—
Jaw f/Coated Pipe	—	40222	40222	—	—
3 Jaw Screw with Washer (2)	92615	32457	32457	41090	41145
4 Roll Pin	41035	41035	41035	41110	41110
5 Chain Screw Pin	41040	41040	41040	41115	41115
6 Nut Locking Pin	31625	31650	31650	31715	31715
7 Handle Assembly	41000	41050	41050	41125	41125
8 Handle	40970	41015	41015	41080	41080
9 Swivel Nut Assembly	41010	41060	41060	41135	41135
10 Friction Ring	40975	41025	41025	41100	41100
11 Chain Screw	40980	41065	41065	41095	41095
12 Chain Link Assembly	68625	68625	68625	68630	68630
13 Base Assembly	40995	41045	41070	41120	41150
14 Spool (2)	40740	40450	40450	40450	40655
15 Roll	40990	40990	40990	41105	41105

Nos. BC-2A, BC-4A

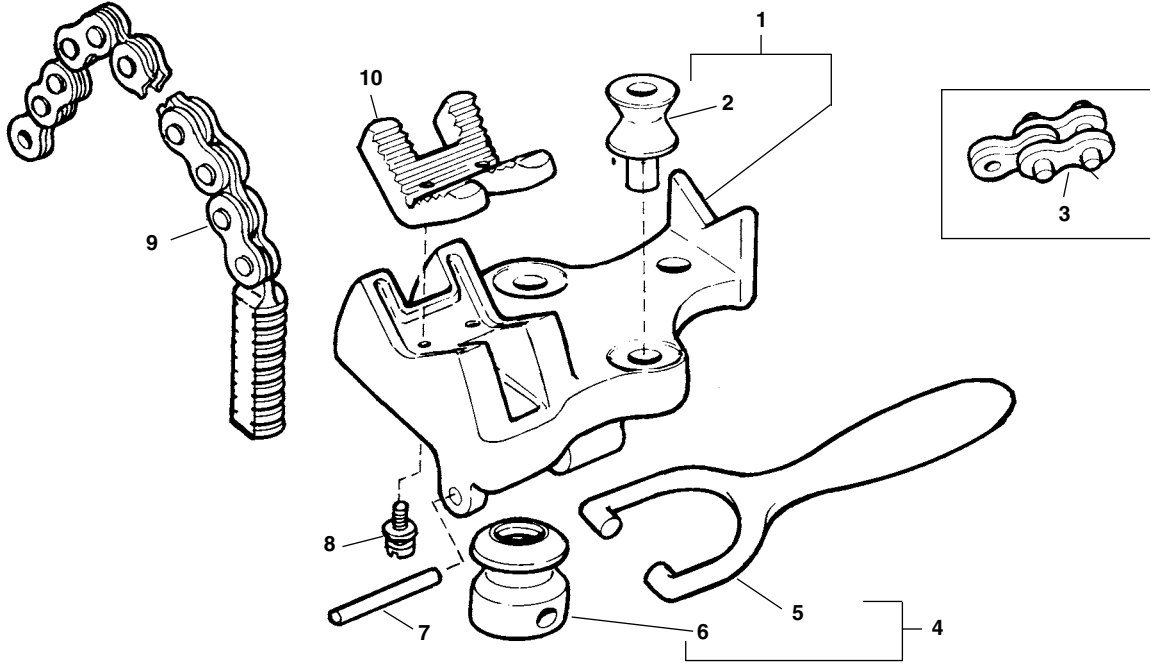

**NOTE: Order parts by Catalog Number only.
DO NOT order by Reference Number.**

Ref. No.	Description	BC-2A	BC-4A
		1/8"-2"	1/8"-4"
1	Base Assembly	40695	40745
2	Spool (2)	40740	40450
3	Chain Link Assembly	68625	68625
4	Handle Assembly	40725	40765
5	Handle	32190	32190
6	Swivel Nut	40720	40760
7	Nut Locking Pin	40730	40775
8	Jaw Screw with Washer (2)	40735	40785
9	Chain and Screw Assembly	40715	40755
10	Jaw	40985	41020
	Jaw f/Plastic Pipe	41275	41280
	Jaw f/Coated Pipe	—	40222

Capacity: 1/8", through 2 1/2"

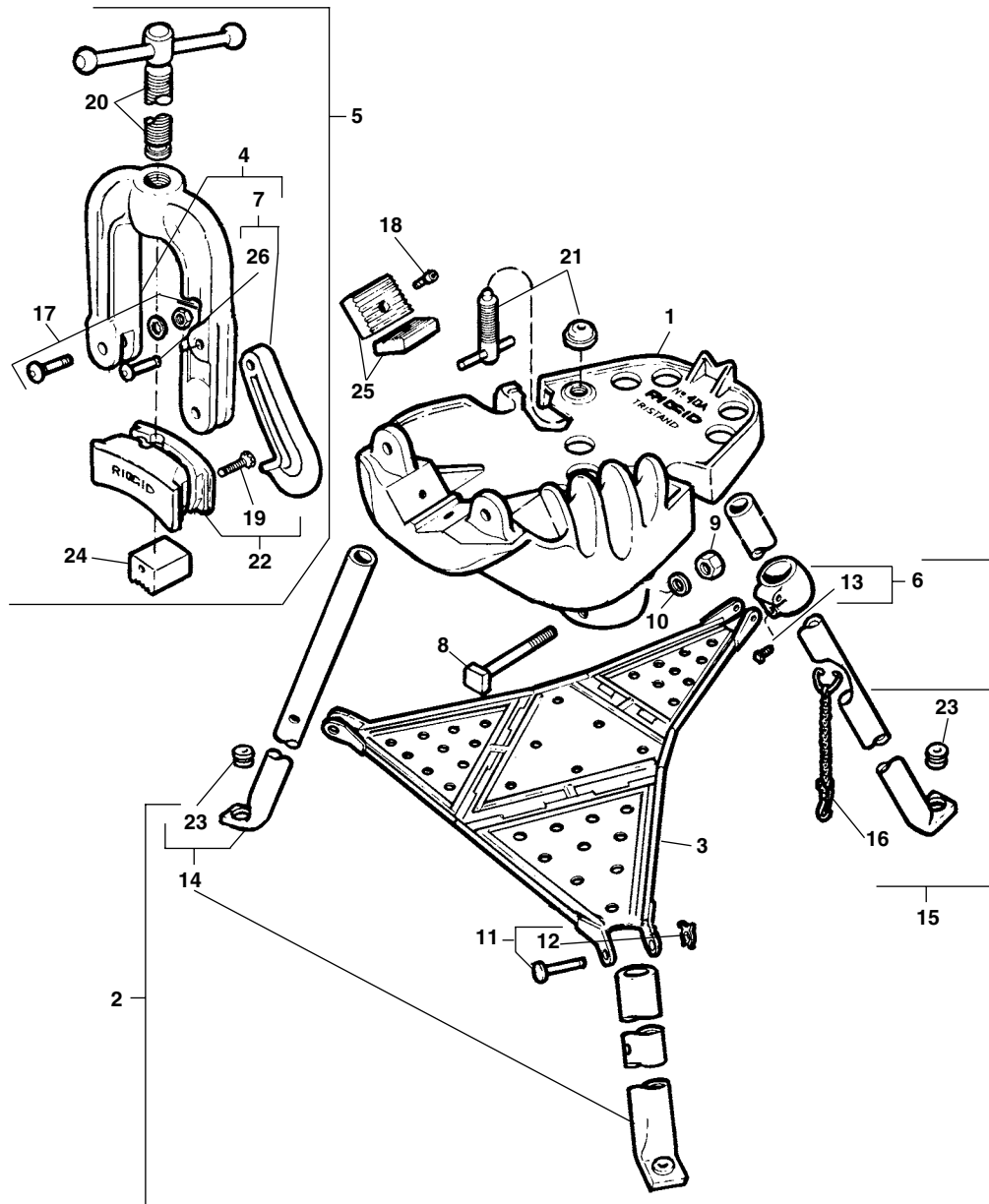

**NOTE: Order parts by Catalog Number only.
DO NOT order by Reference Number.**

Ref. No.	Catalog No.	Description	Ref. No.	Catalog No.	Description
1	40895	Base	14	41255	Front Leg Assembly (2)
2	40915	Legs & Tray Assembly	15	41250	Rear Leg Assembly
3	41240	Tool Tray	16	40945	Leg Chain
4	40900	Yoke & Hook Assembly	17	40905	Hinge Bolt, Nut & Washer
5	40920	Yoke Assembly	18	40910	Lower Jaw Screw (2)
6	41235	Tray Support with Screw	19	40385	Jaw Clamp Screw with Washer (2)
7	40380	Hook Assembly	20	40390	Feed Screw
8	46675	Leg Bolt	21	41230	Jack Screw Assembly
9	44225	Nut (3)	22	40395	Jaw Clamp Set
10	40930	Lock Washer (3)	23	40940	Grommet (3)
11	41265	Tray Pin & Washer (3)	24	40400	Upper Jaw
12	41270	"X" Washer (3)	25	40405	Lower Jaw (1 Set)
13	41245	Set Screw	26	40415	Hinge Pin

Capacity: 1/8", through 2 1/2"

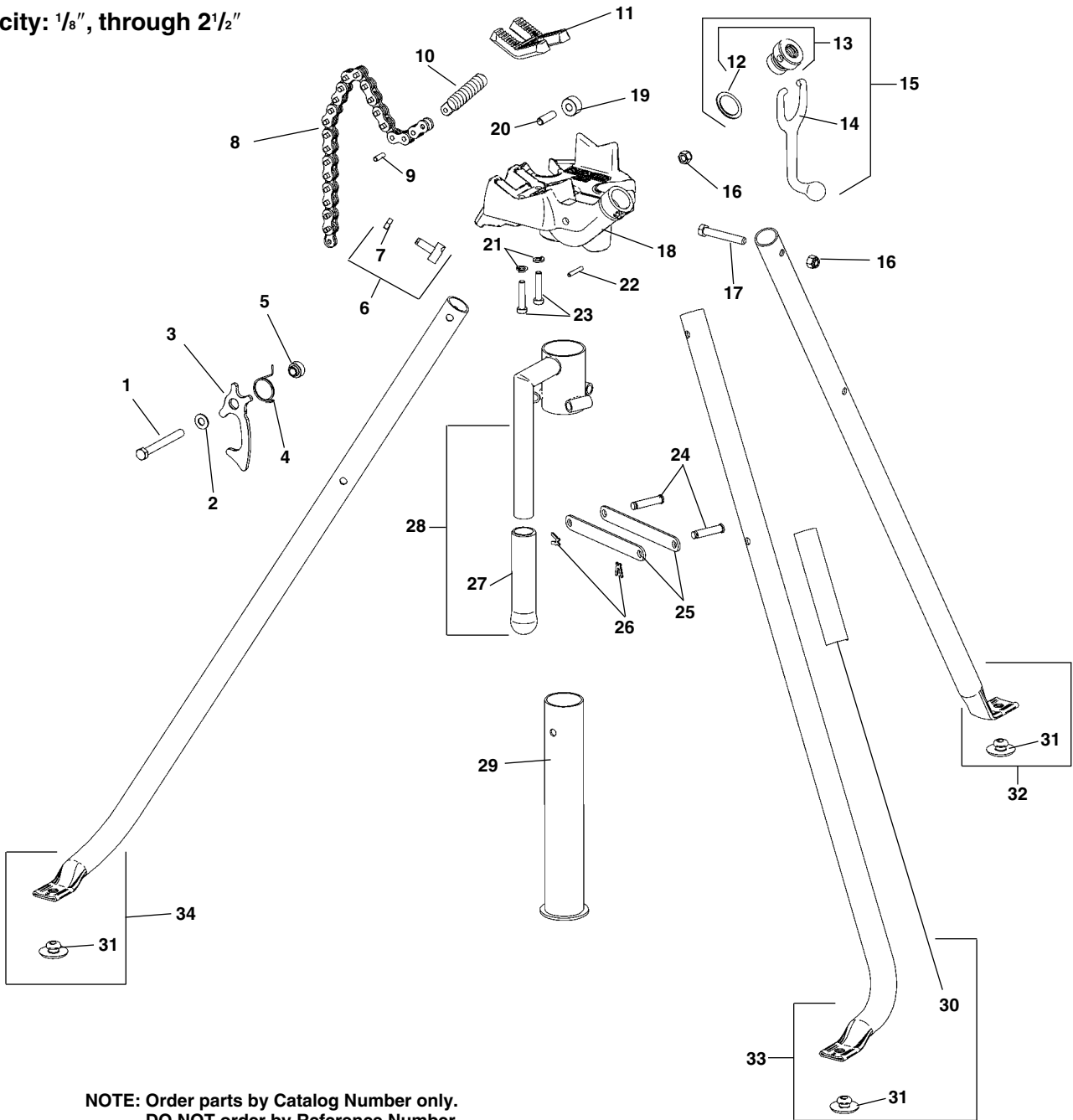

**NOTE: Order parts by Catalog Number only.
DO NOT order by Reference Number.**

Ref. No.	Catalog No.	Description	Ref. No.	Catalog No.	Description
—	16703	425 Tristand	18	19053	Base
1	19063	Hex Bolt, 3/8" - 16 x 3 1/2"	19	40990	Roll
2	59970	Flat Washer, 3/8"	20	41035	Roll Pin
3	19118	Latch	21	40770	Lock Washer, 3/8" (2)
4	19113	Torsion Spring	22	76735	Spring Pin
5	19108	Latch Bushing	23	32457	Screw w/Washer (2)
6	19103	Adjuster Shoe Assembly	24	19083	Pivot Pin (6)
7	83545	Jam Nut, 3/8" - 16"	25	19088	Link (6)
8	41005	Chain Assembly	26	41270	X-Washer (6)
9	41040	Chain Screw Pin	27	18228	Hand Grip
10	41065	Chain Screw	28	19093	Center Ring w/Handle
11	41020	Jaw	29	19098	Center Tube
12	41025	Friction Ring	30	19533	RIDGID Label
13	41060	Swivel Nut w/Friction Ring	31	40940	Grommet (3)
14	41015	Handle	32	19068	Rear Leg Assembly
15	41050	Handle Assembly	33	19078	Right Leg Assembly
16	79985	Lock Nut, 3/8" - 16 (4)	34	19073	Left leg Assembly
17	58052	Hex Bolt, 3/8" - 16 x 2 1/2" (3)			

Capacity: 1/8", through 5"

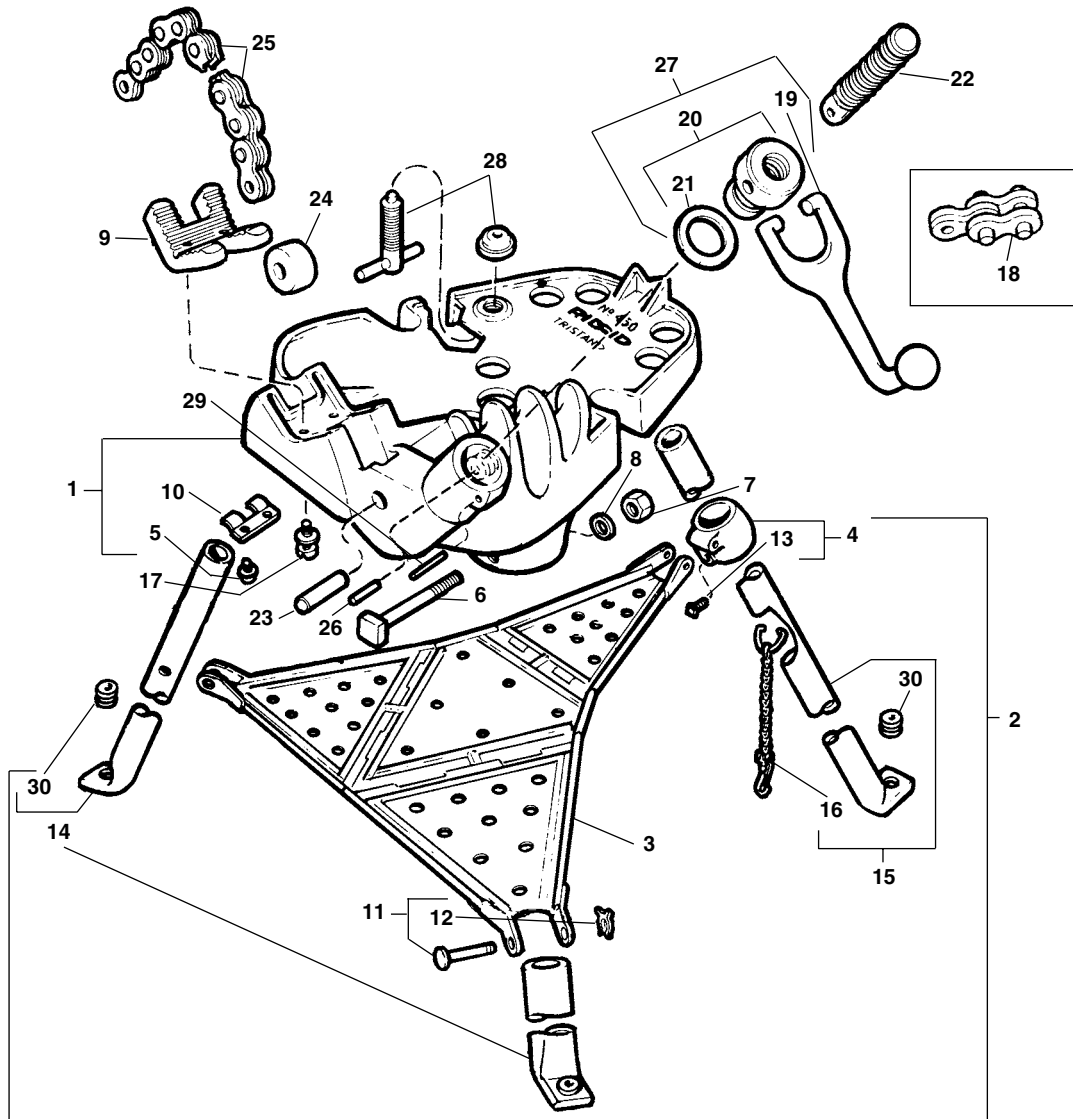

**NOTE: Order parts by Catalog Number only.
DO NOT order by Reference Number.**

Ref. No.	Catalog No.	Description	Ref. No.	Catalog No.	Description
1	72097	Base with Wear Plate and Screws	15	41250	Rear Leg Assembly
2	40915	Leg & Tray Assembly	16	40945	Leg Chain
3	41240	Tool Tray	17	41090	Jaw Screw with Washer (2)
4	41235	Tray Support with Screw	18	68625	Link
5	40960	Screw with Washer (2)	19	41015	Handle
6	46675	Leg Bolt (3)	20	41060	Swivel Nut with Friction Ring
7	44225	Nut (3)	21	41025	Friction Ring
8	40930	Lock Washer (3)	22	41065	Chain Screw
9	41020	Jaw	23	41035	Roll Pin
	41280	Jaw for Plastic Pipe	24	40990	Roll
	40222	Jaw for Coated Pipe	25	72092	Chain Assembly
10	40955	Wear Plate	26	41040	Chain Screw Pin
11	89720	Tray Pin with "X" Washer (3)	27	41050	Handle Assembly
12	41270	"X" Washer (3)	28	41230	Jack Screw Assembly
13	41245	Set Screw	29	31650	Nut Locking Pin
14	41255	Front Leg Assembly (2)	30	40940	Grommet (3)

Capacity: 1/8", through 6"

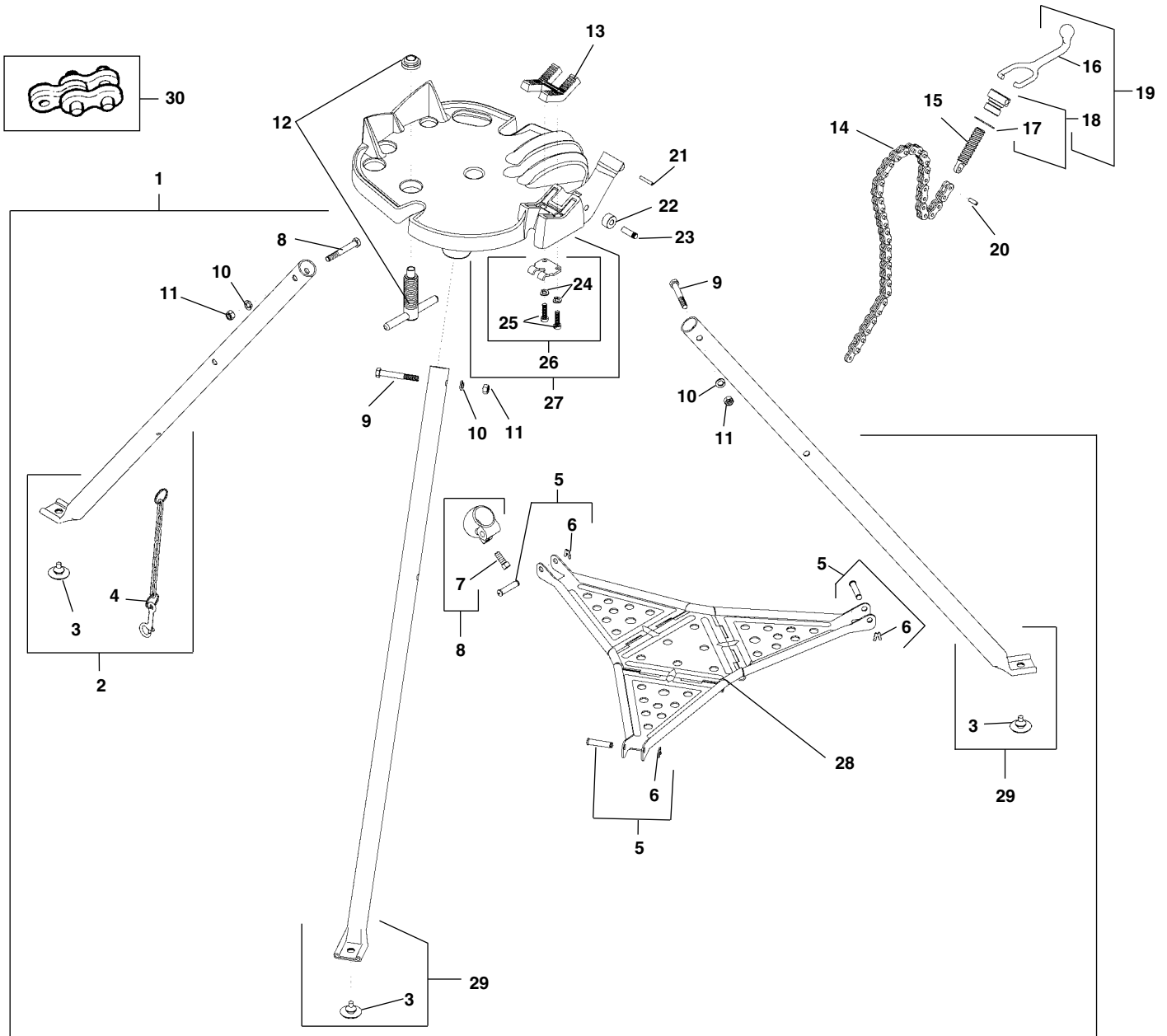

**NOTE: Order parts by Catalog Number only.
DO NOT order by Reference Number.**

Ref. No.	Catalog No.	Description	Ref. No.	Catalog No.	Description	Ref. No.	Catalog No.	Description
—	72037	460 Tristand	11	44225	Nut 3/8" - 16 (3)	21	31650	Nut Locking Pin
—	72042	460E Tristand Export	12	72102	Jack Screw Assembly	22	40990	Roll
1	40915	Leg & Tray Assembly	13	41020	Jaw	23	41035	Roll Pin
2	41250	Rear Leg Assembly		41280	Jaw for Plastic Pipe	24	60080	Washer, 5/16"
3	40940	Grommet (3)		40222	Jaw for Plastic Coated Pipe	25	95397	Screw, 5/16" - 18 x 2"
4	40945	Leg Chain	14	72092	Chain Assembly	26	93537	Wear Plate
5	41265	Tray Pin with "X" Washer (3)	15	41065	Chain Screw	27	72097	Base with Wear Plate and Screws
6	41270	"X" Washer (3)	16	41015	Handle	28	41240	Tool Tray
7	41235	Tray Support with Screw	17	41025	Friction Ring	29	41255	Front Leg Assembly (2)
8	41245	Set Screw	18	41060	Swivel Nut w/Friction Ring	30	68625	Chain Extension Link
9	46675	Hex Bolt 3/8" - 16 x 2 3/4" (3)	19	41050	Handle Assembly			
10	40930	Lock Washer 3/8" (3)	20	41040	Chain Screw Pin			

Capacity: 1/8", through 5"

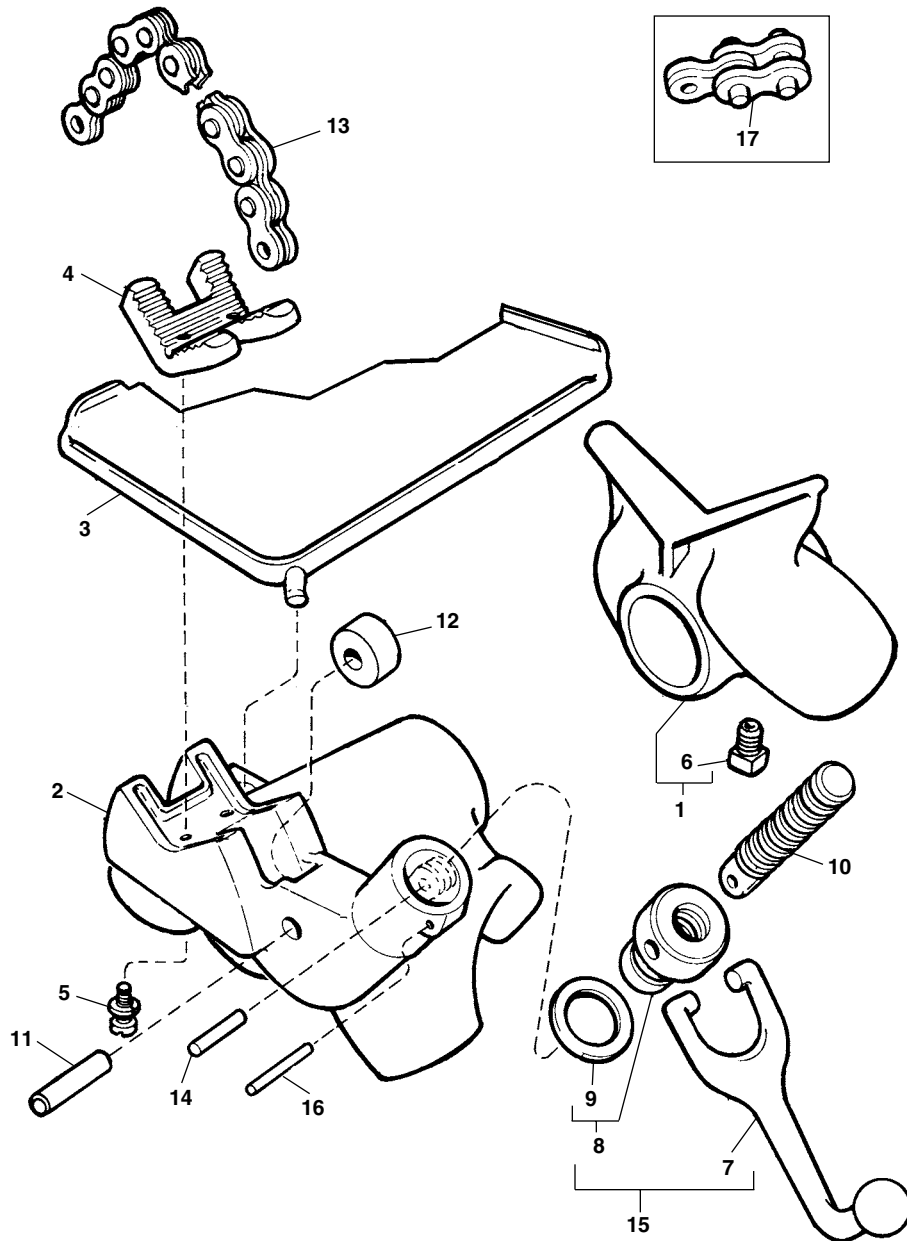

**NOTE: Order parts by Catalog Number only.
DO NOT order by Reference Number.**

Ref. No.	Catalog No.	Description	Ref. No.	Catalog No.	Description
—	40165	560 Stand Chain Vice	9	41025	Friction Ring
1	40850	Rear Support with Set Screw	10	41065	Chain Screw
2	41165	Base	11	41035	Roll Pin
3	40845	Tool Tray	12	40990	Roll
4	41020	Jaw	13	41075	Chain Assembly
	41280	Jaw for Plastic Pipe	14	41040	Chain Screw Pin
	40222	Jaw for Coated Pipe	15	41050	Handle, Swivel Nut & Friction Ring Assembly
5	40785	Jaw Screw & Washer (2)	16	31650	Nut Locking Pin
6	40855	Set Screw	17	68625	Link
7	41015	Handle			
8	41060	Swivel Nut with Friction Ring			

Capacity: 1/8", through 5"

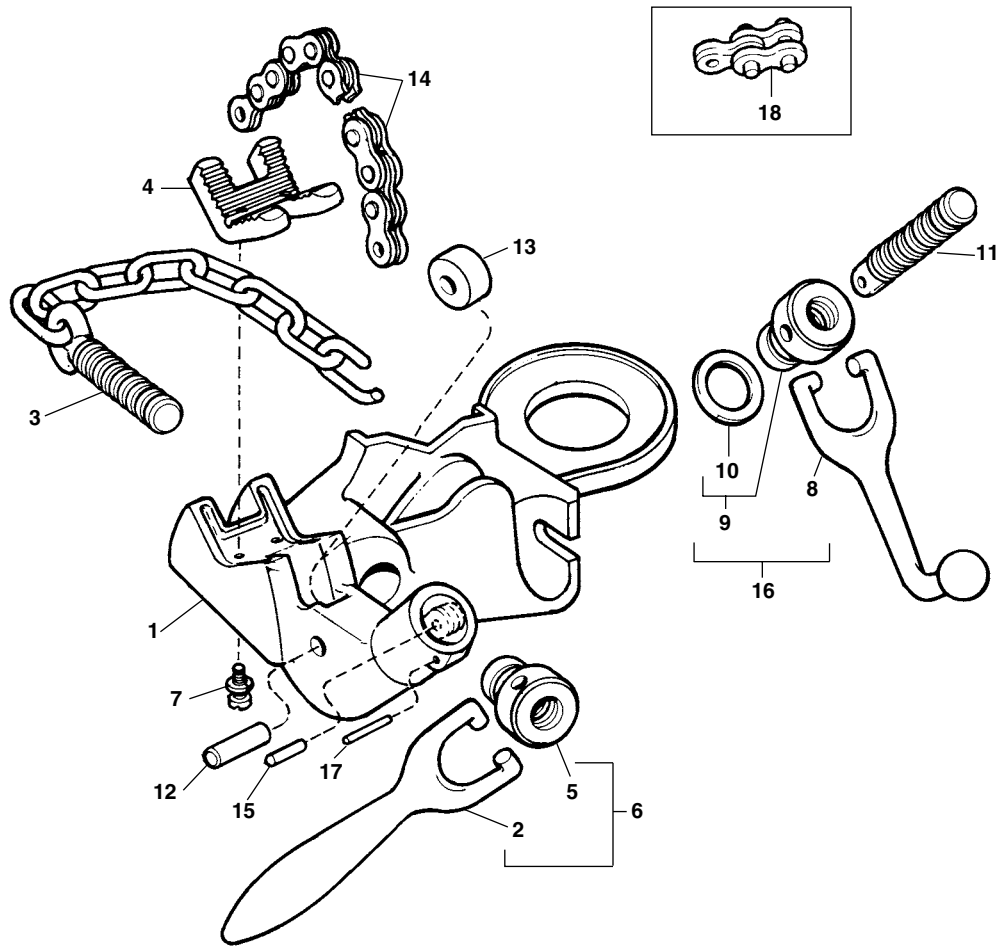

**NOTE: Order parts by Catalog Number only.
DO NOT order by Reference Number.**

Ref. No.	Catalog No.	Description	Ref. No.	Catalog No.	Description
—	40170	640 Post Chain Vise	9	41060	Swivel Nut with Friction Ring
1	41160	Base	10	41025	Friction Ring
2	32190	Handle	11	41065	Chain Screw
3	40825	Coin Chain & Eye Bolt Assembly	12	41035	Roll Pin
4	41020	Jaw	13	40990	Roll
	41280	Jaw for Plastic Pipe	14	41075	Chain Assembly
	40222	Jaw for Coated Pipe	15	41040	Chain Screw Pin
5	40830	Swivel Nut	16	41050	Handle Assembly
6	40820	Handle Assembly	17	31650	Nut Locking Pin
7	41090	Jaw Screw with Washer (2)	18	68625	Link
8	41015	Handle			

No. 39

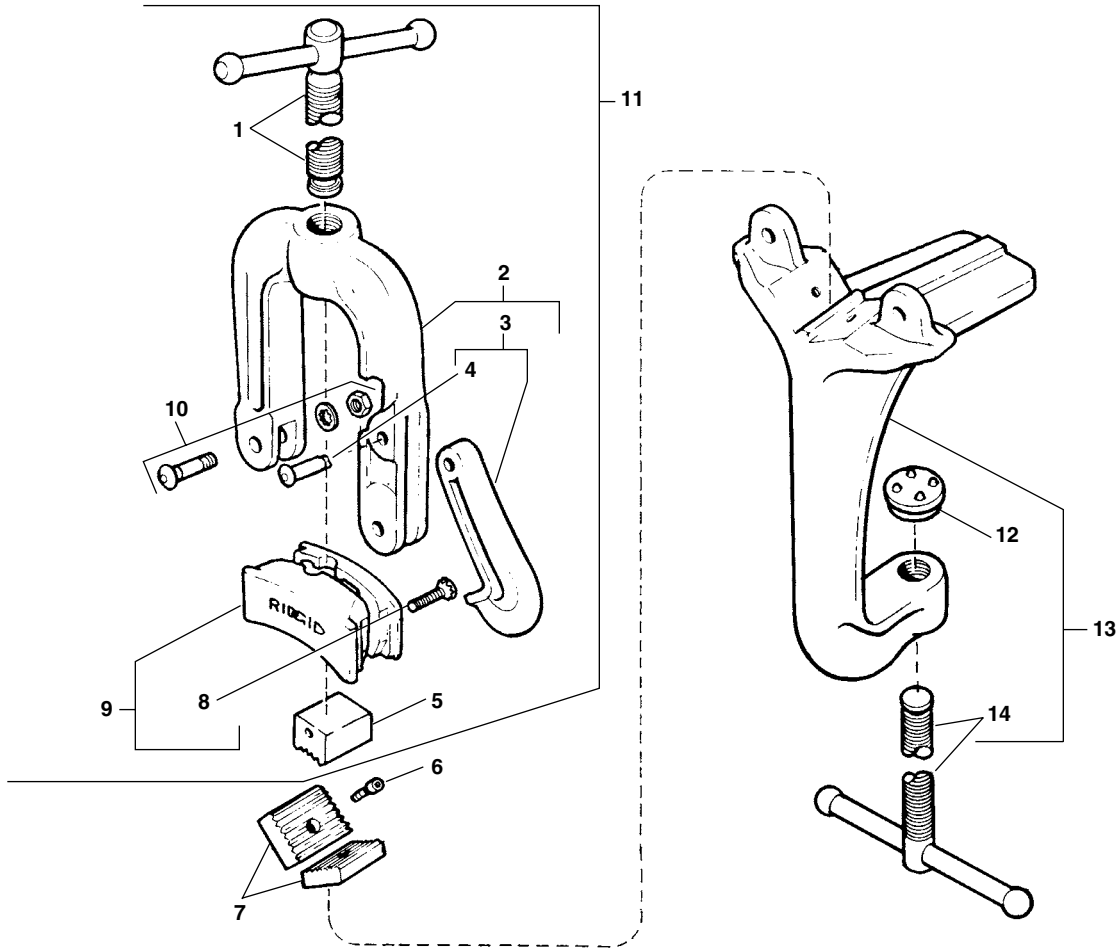

**NOTE: Order parts by Catalog Number only.
DO NOT order by Reference Number.**

		39 <i>1/8"-2 1/2"</i>
Ref. No.	Description	Catalog No.
—	Portable Kit Vise Kit	40125
1	Feed Screw	40390
2	Yoke and Hook Assembly	40370
3	Hook Assembly	40380
4	Hinge Pin	40415
5	Upper Jaw	40400
6	Lower Jaw Screw (2)	32205
7	Lower Jaw (1 Set)	40405
8	Jaw Clamp Screw and Washer (2)	40385
9	Jaw Clamp Assembly	40395
10	Bolt, Washer & Nut	40410
11	Yoke Assembly (Complete)	40375
12	Pad	40880
13	Base Assembly	40890
14	Clamp Screw	40355

No. 461 Straight Pipe Vise

Capacity: 1/2" through 8"

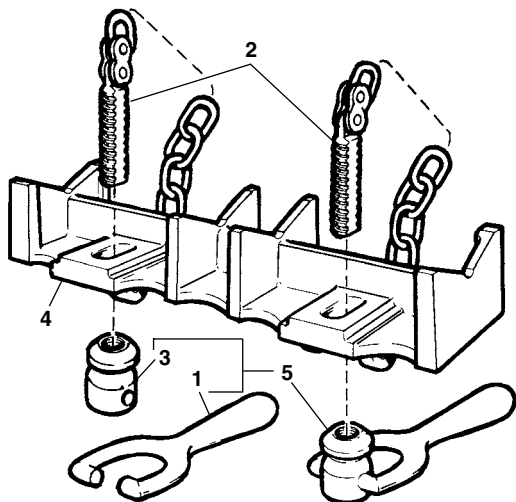

No. 463 Elbow Pipe Vise

Capacity: 2 1/2" through 8"

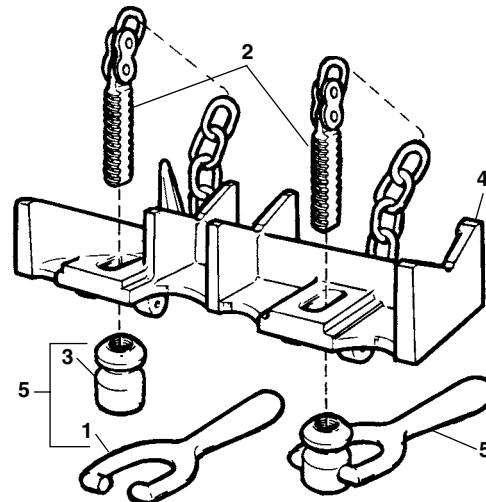

No. 462 Angle Pipe Vise

Capacity: 1/2" through 12"

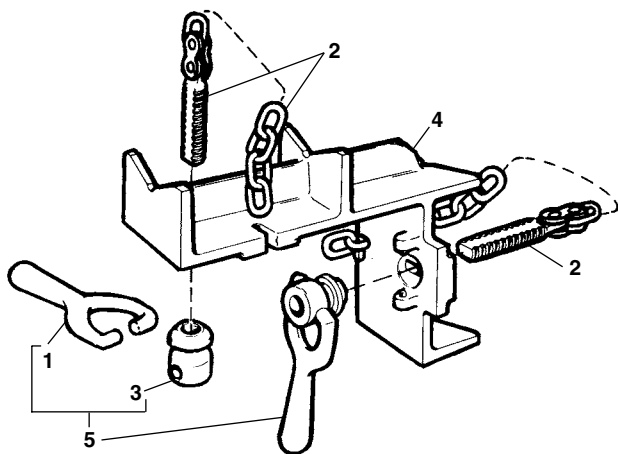

No. 464 Flange Pipe Vise

Capacity: 2 1/2" through 8"

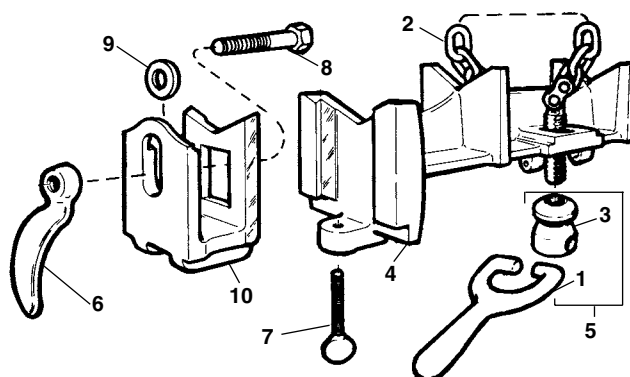

**NOTE: Order parts by Catalog Number only.
DO NOT order by Reference Number.**

Ref. No.	Description	461 Catalog No.	462 Catalog No.	463 Catalog No.	464 Catalog No.
1	Handle (2)*	32190	32190	32190	32190
2	Coil Chain and Screw Assembly (2)	41180	41180	41180	41180
3	Nut (2)*	40720	40720	40720	40720
4	Base w/Pivot Pins	41185	41190	41195	41225
5	Handle and Nut (2)*	40725	40725	40725	40725
6	Clamp Lever	—	—	—	41205
7	Adjusting Screw	—	—	—	41210
8	Bolt	—	—	—	41215
9	Flat Washer	—	—	—	41220
10	Slide Bracket	—	—	—	41200

F-Series

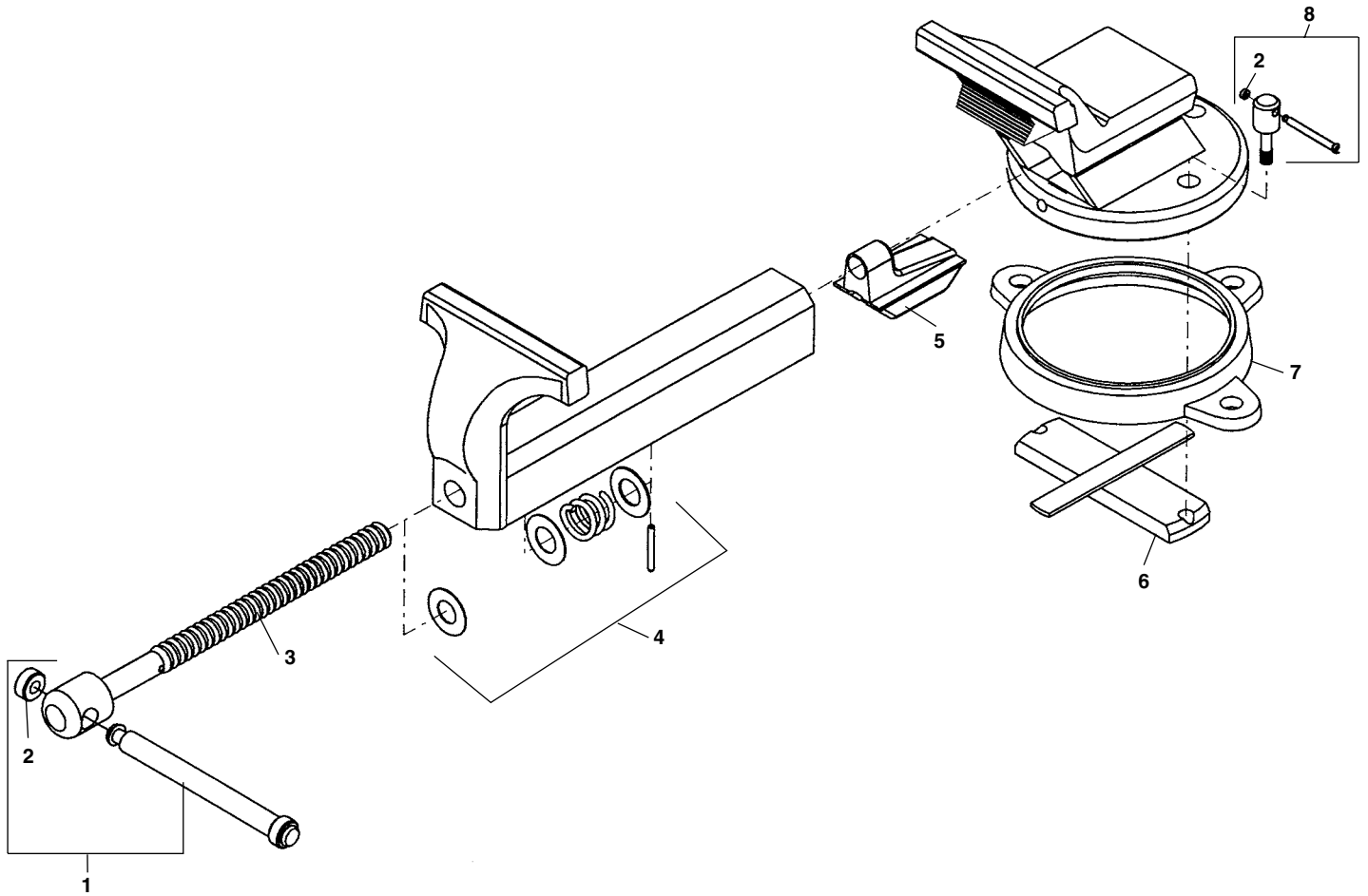

**NOTE: Order parts by Catalog Number only.
DO NOT order by Reference Number.**

Ref. No.	Description	F-45 Catalog No.	F-50 Catalog No.	F-60 Catalog No.
1	Handle, Handle Rings	67432	67437	67442
2	Handle Rings	67462	67467	67472
3	Feed Screw	67397	67402	67407
4	Spring Assembly	67337	67377	67357
5	Vise Nut	67447	67452	67457
6	Clamp Strap	67352	67392	67392
7	Swivel Base Plate	67347	67387	67387
8	T-Screw Assembly (2)	67342	67382	67382

No. 375

Capacity: 1/2" – 1" (37°)

No. 455

Capacity: 1/2" – 1" (45°)

No. 454-W

Capacity: 3/8" – 1" (45°)

No. 454-J

Capacity: 8,10,13,20 SU (45°)

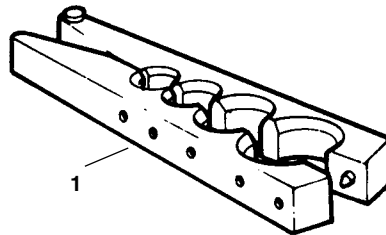

NOTE: Order parts by Catalog Number only.
DO NOT order by Reference Number.

Ref. No.	Catalog No.	Description
1	41395	No. 454-W Flaring Bar Assembly
	93122	No. 454-J Flaring Bar Assembly
	41400	No. 375 Flaring Bar Assembly
	41405	No. 455 Flaring Bar Assembly
2	41540	45 Degree Cone
	41555	37 Degree Cone
3	41360	Yoke & Shaft Assembly
4	41430	Shaft Assembly
5	41535	Thrust Bearing
6	41545	Pin
7	35520	Spring Washer
8	41435	Yoke Assembly w/Needle Bearing & Sleeve
9	41445	Latch and Spring Assembly
10	41410	Retaining Ring
11	41440	Handle with Pin
12	41515	Clamp Screw Assembly

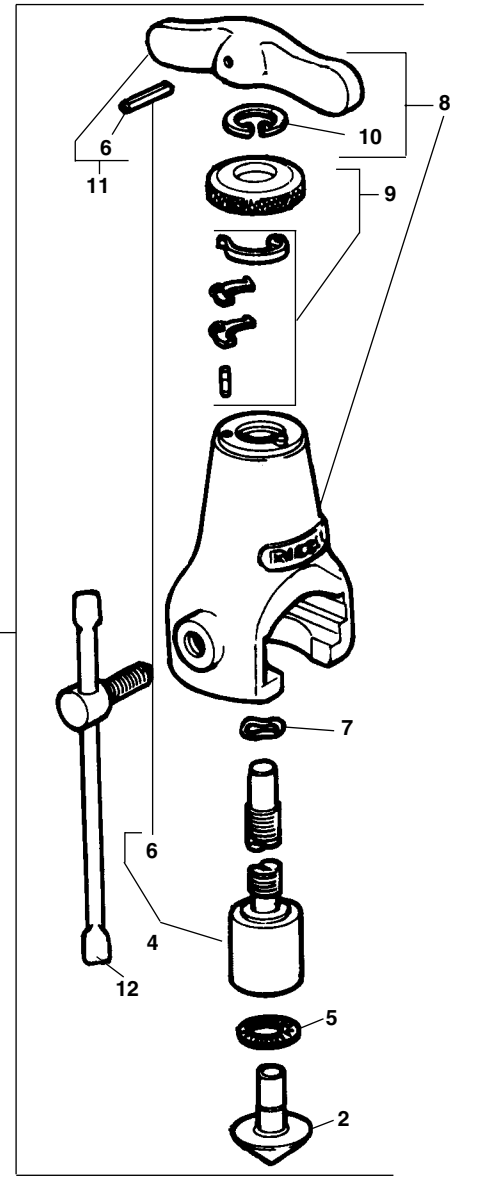

345/345M

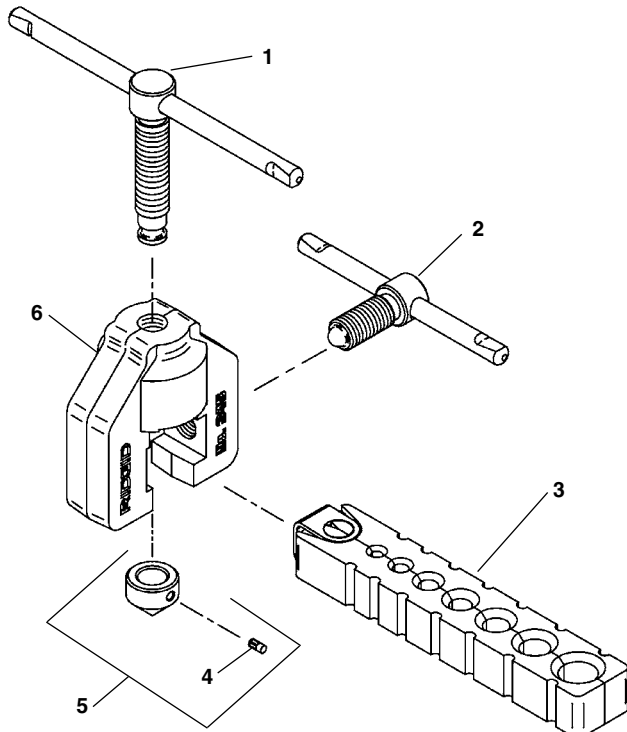

Ref. No.	Catalog No.	Description
—	23332	345 Flare Tool
—	23342	345M Flare Tool - Metric
1	96587	Feed Screw Assembly
2	96607	Clamp Screw Assembly
3	96602	Flare Bar Assembly
	97482	Flare Bar Assembly Metric
4	96597	Pin
5	96592	Cone w/Pin
6	96612	Yoke

No. 458R

Capacity: 1/8" through 3/4"

No. FT-456R

Capacity: 1/4" through 3/4"

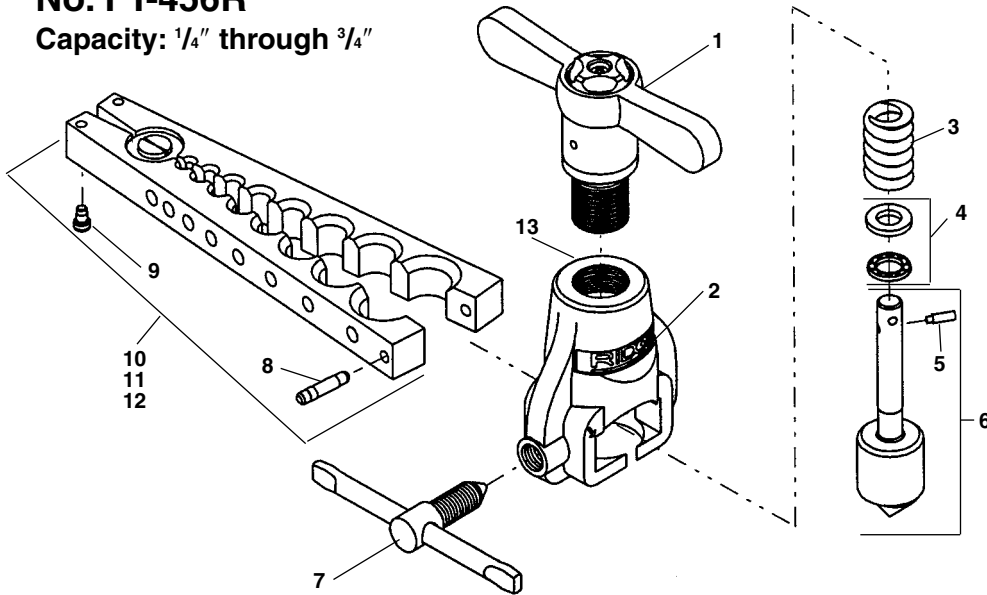

NOTE: Order parts by Catalog Number only. DO NOT order by Reference Number.

Ref. No.	Catalog No.	Description
—	70677	FT 456R Flare Tool F/Japan
—	83037	458R Flare Tool
1	83287	Ratchet Head Assembly
2	39722	Yoke Assembly
3	41485	Feed Spring
4	41520	Bearing Assembly
5	41505	Plunger Pin
6	41475	45° Shaft Assembly
7	41515	Clamp Screw Assembly
8	41455	Locating Pin
9	41450	Stop Pin
10	83282	FT 456R Flaring Bar Assembly
11	39727	458R Flaring Bar Assembly
12	50267	458mm Flaring Bar Assembly
13	76612	Plastic Washer - FT 456R

Ratchet Head Assembly

45° Shaft Assembly

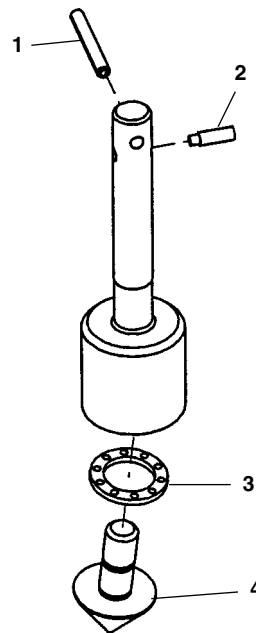
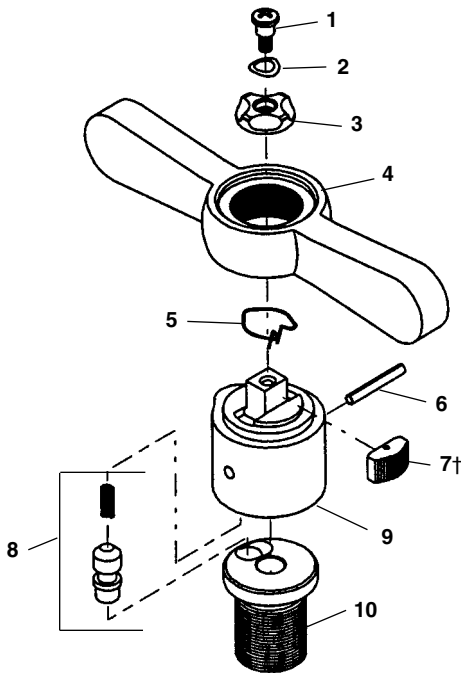

Ref. No.	Catalog No.	Description
—	83287	Ratchet Head Assembly
1	83232	Screw
2	83237	Wave Spring Washer
3	83242	Reversing Cap Assembly
4	83247	Ratchet Handle Assembly
5	95347	Pawl Spring
6	34400	Spring Pin
7†	83257	Pawl with Pawl Spring
8	83267	Square End Plunger Assembly
9	83262	Ratchet Adapter
10	83272	Ramp Style Feed Screw

Ref. No.	Catalog No.	Description
—	41475	45° Shaft Assembly
1	34400	Spring Pin
2	41505	Plunger Pin
3	41470	Thrust Bearing
4	41460	45° Cone

† Ref. 7 – Position Pawl with Dimple Side Up

No. 458

Capacity: 1/8" through 3/4" (45°)

No. 458MM

Capacity: 4 mm through 16 mm (45°)

No. 377

Capacity: 3/16" through 3/4" (37°)

**NOTE: Order parts by Catalog Number only.
DO NOT order by Reference Number.**

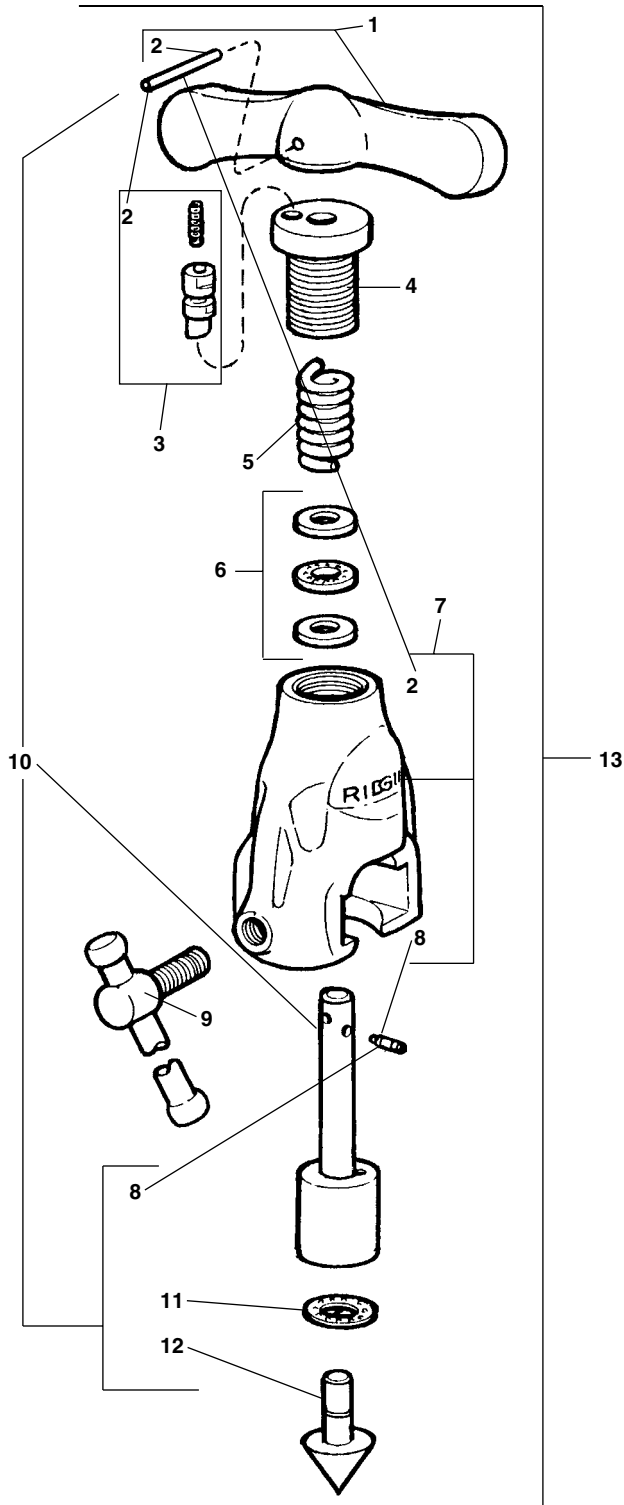

Ref. No.	Catalog No.	Description
1	41495	Handle with Pin
2	41500	Roll Pin
3	41510	Plunger Assembly
4	41525	Feed Screw - 45°
	41490	Feed Screw - 37°
5	41485	Spring
6	41520	Bearing Assembly
7	39722	Yoke Assembly
8	41505	Pin
9	41515	Clamp Screw Assembly
10	41475	Shaft Assembly - 45°
	41480	Shaft Assembly - 37°
11	41470	Thrust Bearing
12	41460	Cone - 45°
	41465	Cone - 37°
13	39742	Yoke and Shaft Assembly - 45°
	42092	Yoke and Shaft Assembly - 37°
14	41450	Stop Pin 2
15	41455	Locating Pin
16	39727	Flaring Bar Assembly - 458
	50267	Flaring Bar Assembly - 458mm
	42102	Flaring Bar Assembly - 377

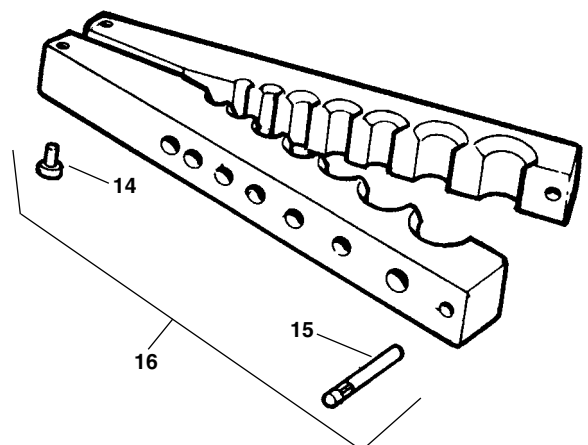

No. 358
No. 368
No. 378

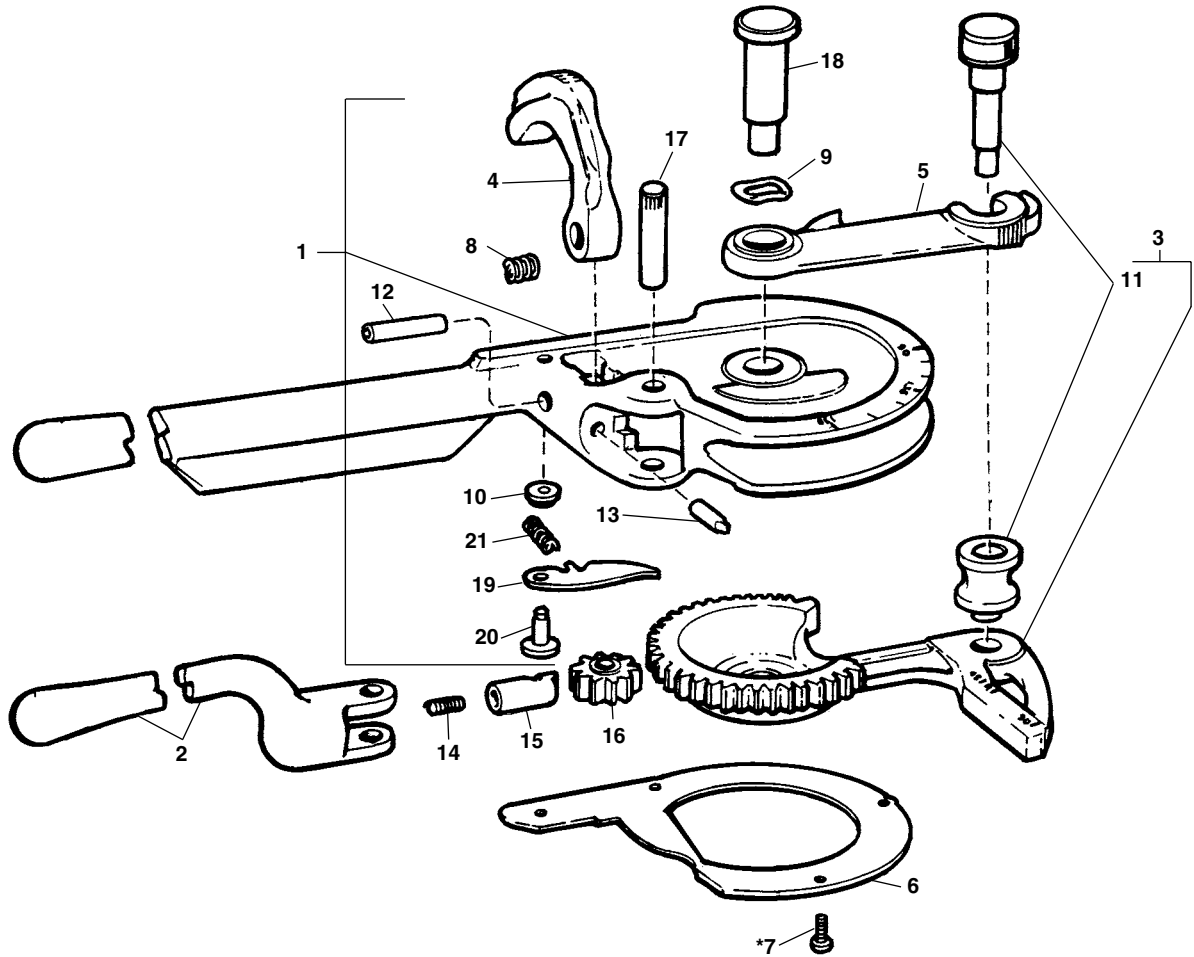

NOTE: Order parts by Catalog Number only.
DO NOT order by Reference Number.

Ref. No.	Description	No. 358	No. 368	No. 378
		$\frac{5}{8}$ " O.D. Tube	$\frac{3}{4}$ " O.D. Tube	$\frac{7}{8}$ " O.D. Tube
Ref. No.	Description	Catalog No.	Catalog No.	Catalog No.
1	Form Handle Assembly	35315	35415	35430
2	Ratchet Handle	35320	35435	35435
3	Drive Arm Assembly	35325	96275	35440
4	Latch	35340	35420	35445
5	Swinging Arm	35330	35450	35450
6	Back Plate	35335	35455	35455
7	Screw (4) 4-40 x $\frac{3}{8}$ " (old style)	46130	46130	46130
	Screw (4) 8-32 x $\frac{3}{8}$ "	43317	43317	43317
8	Latch Spring	35350	35350	35350
9	Wave Spring	35365	35365	35365
10	Holding Pawl Spacer	35405	35405	35405
11	Roll w/Roll Shaft	35345	35425	35460
12	Latch Pin	35355	35465	35465
13	Release Pin	35360	35470	35470
14	Paw Spring	35410	35475	35475
15	Ratchet Pawl	35375	35480	35480
16	Pinion	35380	35485	35485
17	Pinion Pin	35385	35490	35490
18	Pivot Pin	35390	35495	35495
19	Holding Pawl	35395	35500	35500
20	Holding Pawl Pin	35400	35505	35505
21	Holding Pawl Spring	35370	35510	35510

300 Series

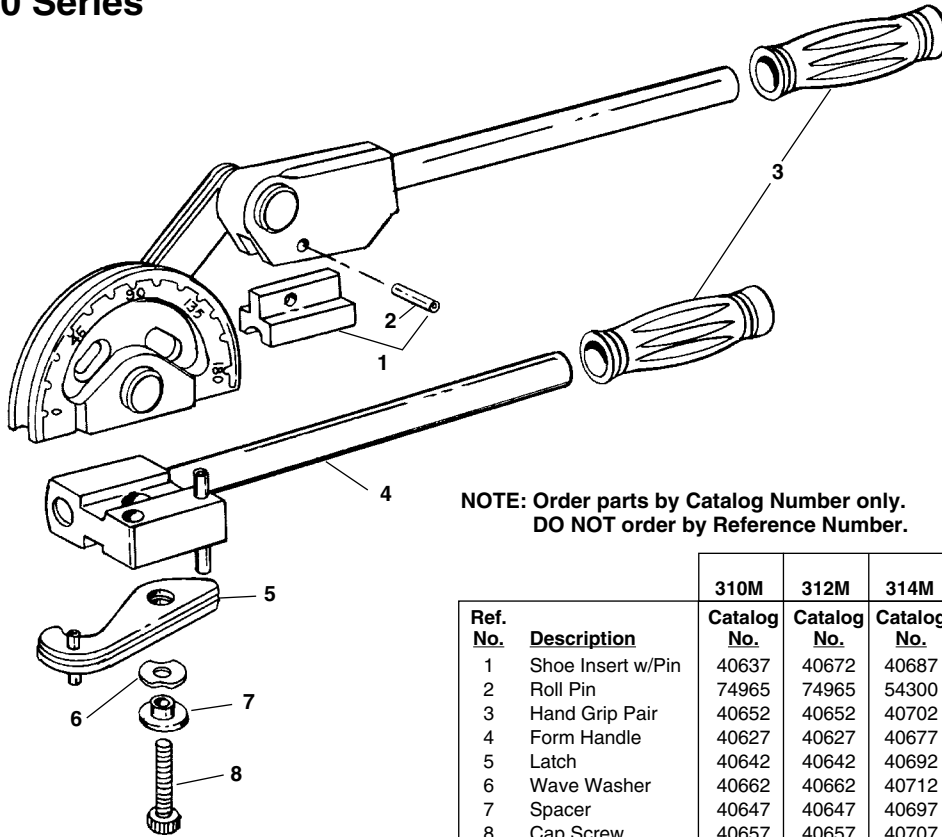

**NOTE: Order parts by Catalog Number only.
DO NOT order by Reference Number.**

		310M	312M	314M	315M	310/ 316M	318M	312	312A
Ref. No.	Description	Catalog No.	Catalog No.	Catalog No.	Catalog No.	Catalog No.	Catalog No.	Catalog No.	Catalog No.
1	Shoe Insert w/Pin	40637	40672	40687	40722	40727	40737	40742	62307
2	Roll Pin	74965	74965	54300	54300	54300	54300	54300	54300
3	Hand Grip Pair	40652	40652	40702	40702	40702	40702	40702	40702
4	Form Handle	40627	40627	40677	40677	40677	40732	44617	44617
5	Latch	40642	40642	40692	40692	40692	40692	40692	40692
6	Wave Washer	40662	40662	40712	40712	40712	40712	40712	40712
7	Spacer	40647	40647	40697	40697	40697	40697	40697	40697
8	Cap Screw	40657	40657	40707	40707	40707	40707	40707	40707

400 Series

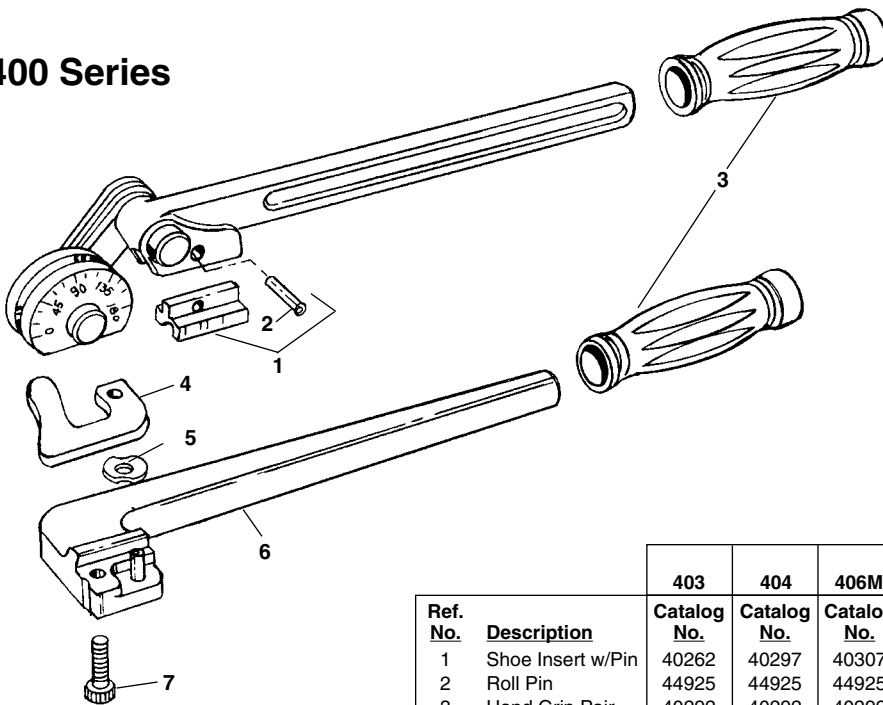

		403	404	406M	405/ 410M	408M	406	408	408A	412M
Ref. No.	Description	Catalog No.	Catalog No.	Catalog No.	Catalog No.	Catalog No.	Catalog No.	Catalog No.	Catalog No.	Catalog No.
1	Shoe Insert w/Pin	40262	40297	40307	40317	40337	40352	40362	26198	40397
2	Roll Pin	44925	44925	44925	34342	34342	34342	74965	74965	74965
3	Hand Grip Pair	40292	40292	40292	40652	40652	40652	40392	40392	40392
4	Latch	40272	40272	40272	40322	40322	40322	40372	40372	40372
5	Wave Washer	40227	40227	40227	40227	40227	40227	40377	40377	40377
6	Form Handle	40282	40302	40312	40327	40347	40357	40382	40382	40402
7	Cap Screw	40267	40267	40267	83685	83685	83685	40367	40367	40367

500 Series

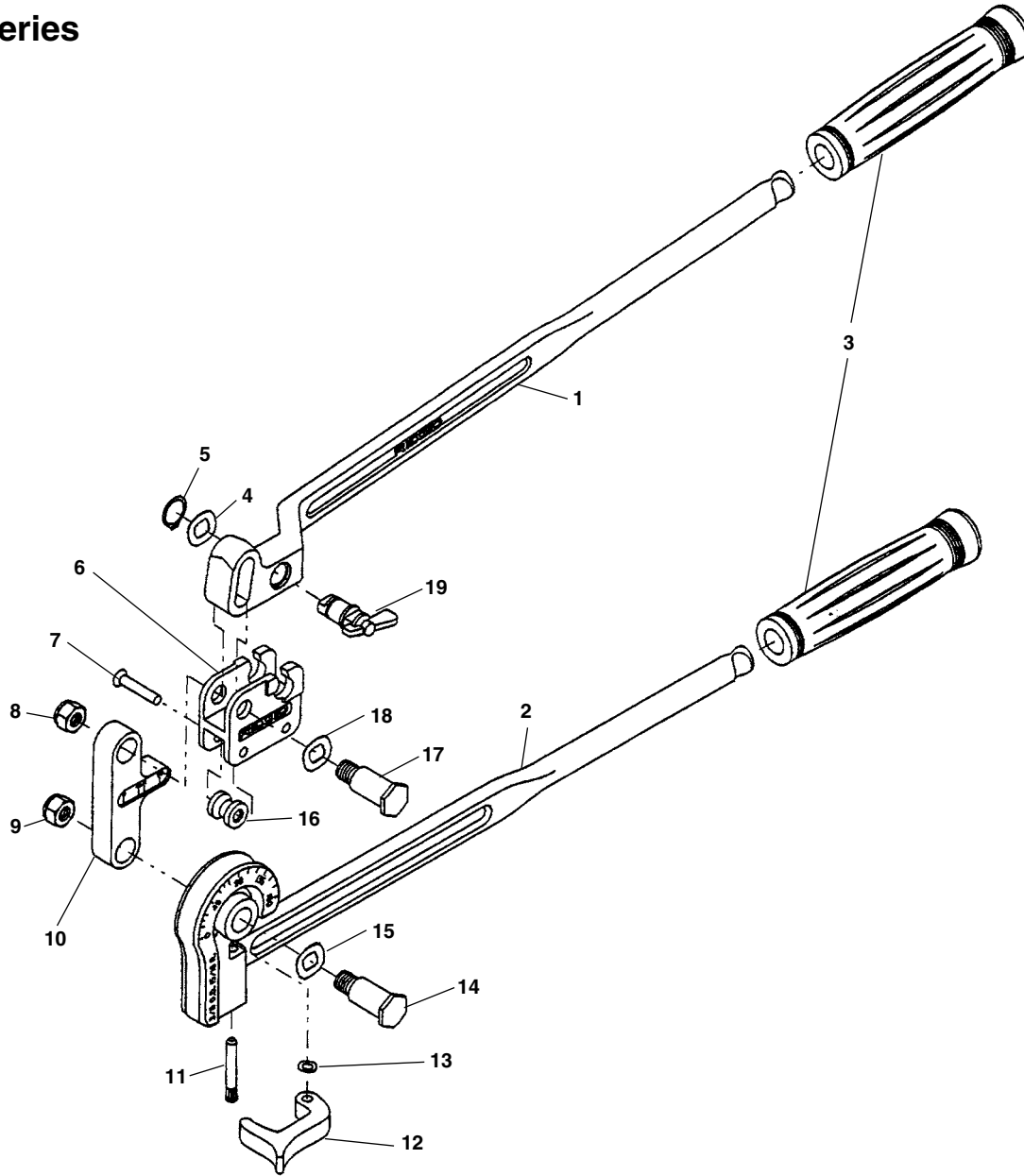

**NOTE: Order parts by Catalog Number only.
DO NOT order by Reference Number.**

Ref. No.	Description	506 Catalog No.	508 Catalog No.
1	Bending Handle	54702	54707
2	Form Handle	54712	54717
3	Hand Grip, Set of 2	54747	54752
4	Wave Washer	54787	54787
5	Retaining Ring	54767	54767
6	Carriage Assy. (Incls. Refs. 7, 16)	57477	57482
7	Rivet Pins, Set of 2	54782	54782
8	Nut	54672	54672
9	Nut	43947	43947
10	Link	54687	54692
11	Pin	32107	33932
12	Latch	54677	54682
13	Washer	54772	54777
14	Bolt, Form Handle	54737	54737
15	Wave Washer	54762	54762
16	Roller Set with Pins	54722	54727
17	Bolt, Shoe Handle	54742	54742
18	Wave Washer	54757	54757
19	Swivel with Washer & Ring	54732	54732

S14
S18
S24
S30
S36
S42

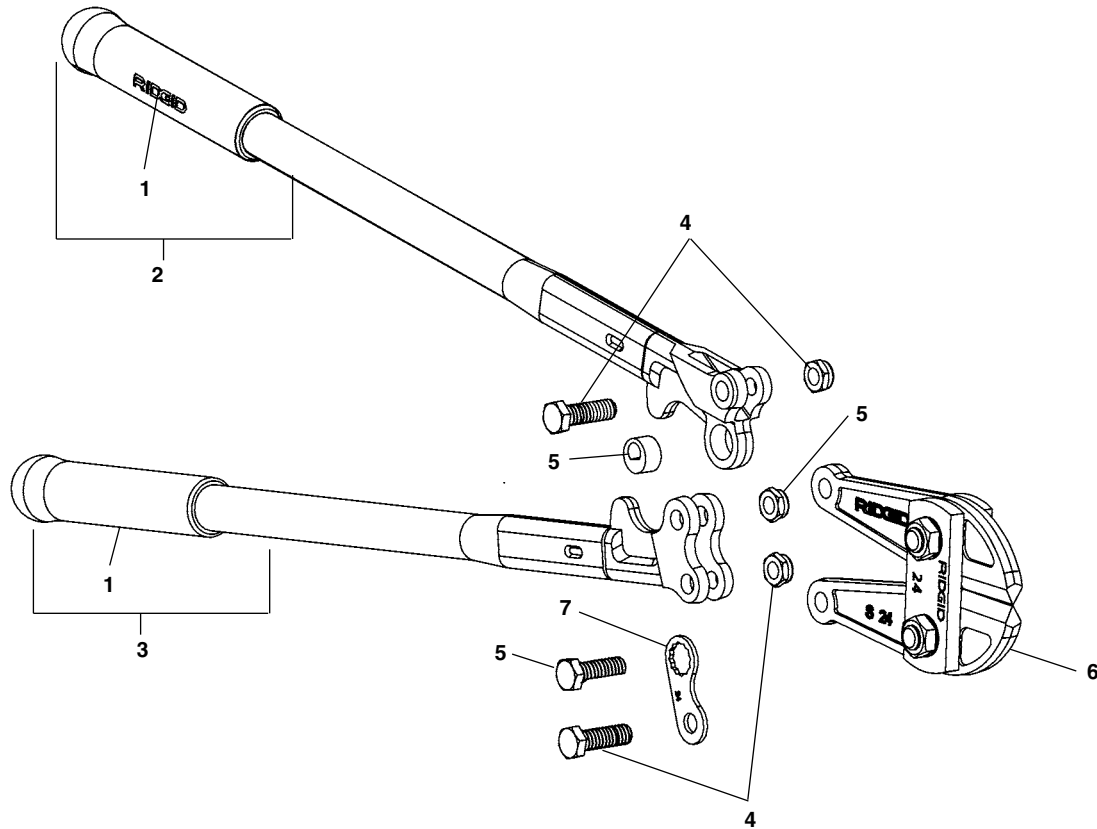

**NOTE: Order parts by Catalog Number only.
DO NOT order by Reference Number.**

Ref. No.	Description	S14 Catalog No.	S18 Catalog No.	S24 Catalog No.	S30 Catalog No.	S36 Catalog No.	S42 Catalog No.
1	Hand Grip	18213	18218	18223	18228	18233	18238
2	Male Handle w/Hand Grip	18243	18248	18253	18258	18263	18268
3	Female Handle w/Hand Grip	18273	18278	18283	18288	18293	18298
4	Lever Bolts w/Locknut	18303	18308	18313	18318	18323	18328
5	Center Cam Bolt w/Locknut and Bushing	18333	18338	18343	18348	18353	18358
6	Head Assembly (Includes Ref. No. 4)	18363	18368	18373	18378	18383	18388
7	Adjustment Plate	18393	18398	18403	18408	18413	18418

Adjustment of Cutter Jaws

1. Loosen hexagon lock nut (ref. 5) located at the opposite side of eccentricity bolt (ref. 5) until head of eccentricity bolt is clear of the adjustment plate.
2. With handles held in closed position, turn eccentricity bolt (ref. 5) until cutting edges are $\frac{1}{64}$ " apart (approx. the same thickness of a piece of paper).
3. Once cutting edges are properly adjusted, retighten lock nut (ref. 5).

NOTE! Before retightening lock nut, make sure proper alignment of cutting edges is maintained.

Replacement of Head Assembly

1. Loosen hexagon lock nut (ref. 5) until head of eccentricity bolt is clear of the adjustment plate.
2. Loosen lock nuts (2) (ref. 4) and remove lever bolts (2) (ref. 4).
3. Remove head assembly.
4. Apply a new head assembly into the groove and insert lever bolts.
5. Repeat the same procedure as adjustment of Cutter Jaws.

Single-Stage, Two-Way Valve

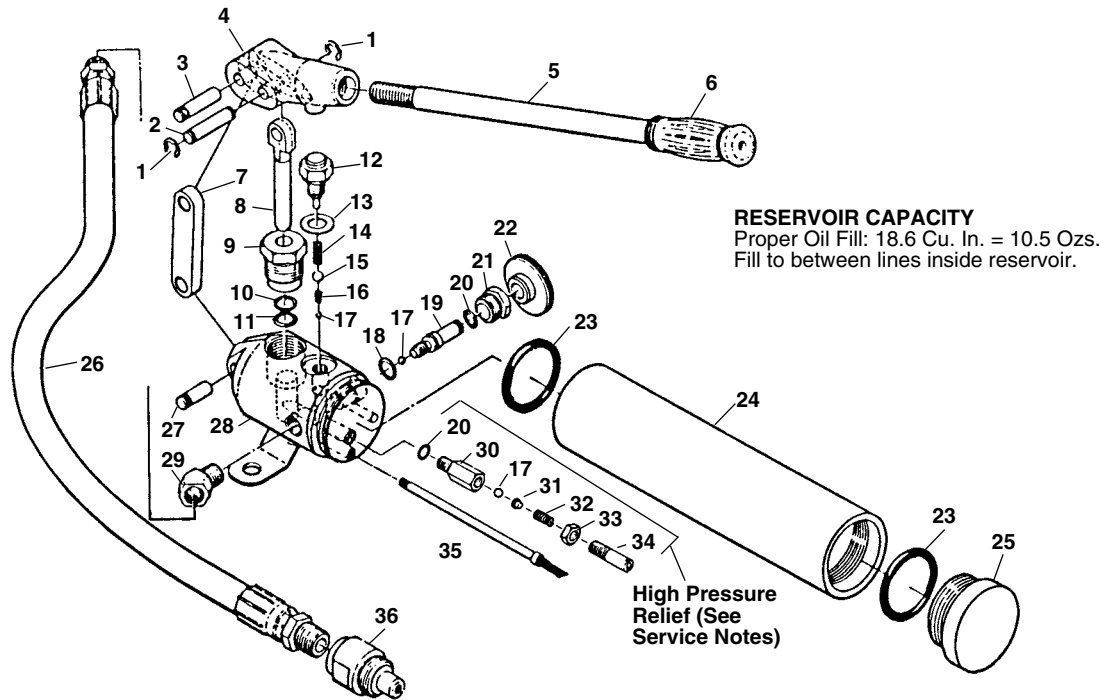

NOTE: Order parts by Catalog Number only. DO NOT order by Reference Number.

NOTE: All components are METRIC dimensions.

Ref. No.	Catalog No.	Description	Ref. No.	Catalog No.	Description
—	24542	H-18 Hand Pump	20	24157*	O-Ring (2)
1	24497*	Snap Ring (6)	21	24167	Valve Guide
2	24492	Pin	22	24172	Knob
3	24202	Pin	23	24507	O-Ring (2)
4	24222	Handle Head	24	24232	Reservoir
5	24502	Handle	25	24237	Reservoir Cap
6	24272	Hand Grip	26	21847	Hydraulic Hose, 3 ft.
7	24487	Lever Crank	27	24207	Pin
8	24127	Piston	28	24122	Pump Body
9	24132	Packing Nut	29	24217	Elbow, 45 Deg., 3/8" NPTF
10	24137*	Back-up Ring	30	24247	Valve Body
11	24142*	O-Ring	31	24252	Ball Guide
12	24177	Spring Stop Bolt	32	24257	Spring
13	24147*	Copper Washer	33	24262	Jam Nut
14	24182*	Spring	34	24267	Adjusting Plug
15	24187*	Steel Ball (6 mm)	35	24197	Intake Tube w/Filter
16	24192*	Spring	36	24107	Hose Half Coupler
17	24152*	Steel Ball (3) (4.8 mm)	Following items not shown:		
18	24227*	Copper Washer	26032*	Decal, Trade Name	
19	24162	Valve Stem	26067	Repair Kit (includes * items)	

Items marked with an asterisk (*) are included in the Repair Kit.
†See Service Notes.

Service Notes for H-18

HIGH PRESSURE RELIEF VALVE SETTING

The High Pressure Relief Valve on this pump is factory preset at 9,400 to 10,500 PSI. The setting can be checked or reset as follows:

- A. Attach a 15,000 PSI gauge to outlet port of pump.
- B. Operate pump cautiously to build pressure while watching gauge.
- C. If maximum pressure exceeds 10,500 PSI:
 1. Stop pumping and open release valve.
 2. Turn adjusting plug, Ref. 34, counterclockwise 1/2 turn and retest.
- D. If maximum pressure is less than 9,400:
 1. Turn adjusting plug clockwise 1/8 turn and retest.
- E. Continue Step "C" or "D" until specified range is achieved. Lock in place with jam nut, Ref. 33.

Knockout Ram

NOTE: Order parts by Catalog Number only. DO NOT order by Reference Number.

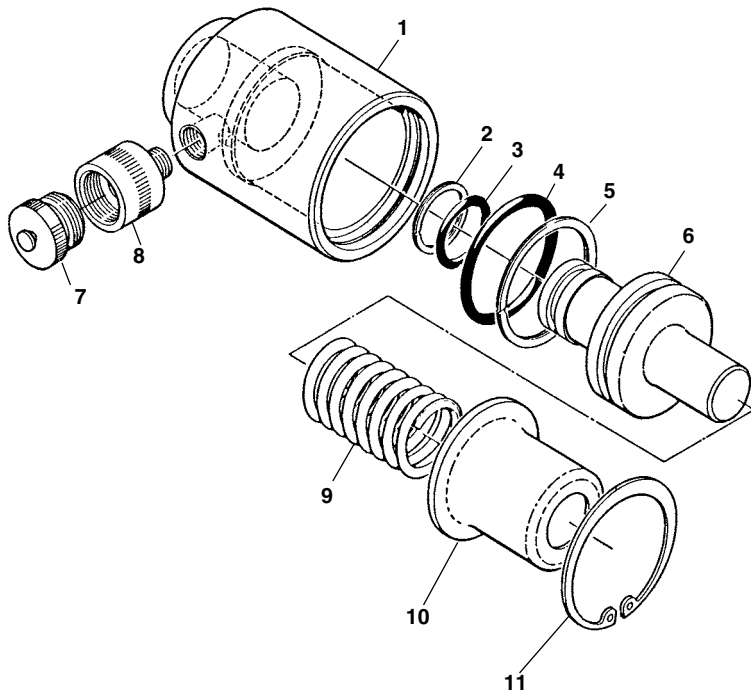

Ref. No.	Catalog No.	Description
—	24537	8R111S Ram
1	24442	Cylinder Body
2	24482*	Back-up Ring
3	24477*	O-Ring
4	24467*	O-Ring
5	24472*	Back-up Ring
6	24452	Piston
7	24117	Dust Cap. Ram Half
8	24112	Ram Half Coupler. 3/8" NPTF
9	24462	Spring
10	24457	End Cap
11	24447	Snap Ring

Following items not shown:
 26042* Decal, Trade Name
 26077 Repair Kit (Includes * items)

Items marked with an asterisk (*) are included in the Repair Kit.
 †See Service Notes.

Service Notes for H-18

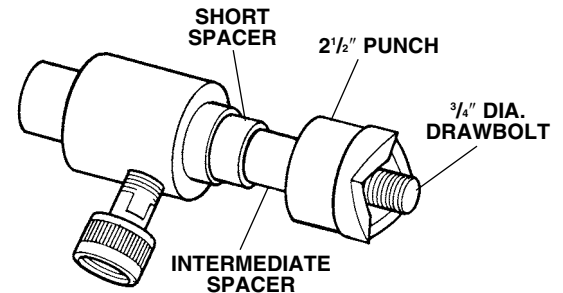

REF. 11 RAM DISASSEMBLY

Spring tension holds End Cap (Ref. 10) firmly against Snap Ring (Ref. 11). To disassemble, apply pressure against End Cap with hand or arbor press to relieve tension against Snap Ring. Remove Snap Ring and allow Spring to expand slowly.

RAM TEST PROCEDURE

This ram can be tested by using the available kit parts as shown in illustration. To achieve maximum hydraulic pressure, block piston and rod travel with the following parts.

NOTE: Do not bottom out piston in cylinder with full stroke at maximum PSI.

1. 3/4" **Draw Bolt**, Catalog No. 17597 – Thread bolt into piston rod hand tight.
2. **Short Spacer** (7/8" long), Catalog No. 17642 – Place short spacer on draw bolt.
3. Intermediate Spacer (1 3/16" long), Catalog No. 17637 – Place intermediate spacer on draw bolt.
4. 2 1/2" **K.O. Punch**, Catalog No. 17527 – Thread punch backwards on draw bolt hand tight.
5. To check for piston seal leakage at start of stroke, apply maximum pressure with pump.
6. To check for piston seal leakage near end of stroke, back off punch 7/8 inch. Apply maximum pressure.

Refer to the Operator's Manual that accompanies this product for detailed information regarding safety, set-up, operation, maintenance, accessories and troubleshooting.

**Address additional inquiries to THE RIDGE TOOL COMPANY,
 ATTN: TECHNICAL SERVICE DEPARTMENT,
 400 CLARK STREET, ELYRIA, OH 44035
 PHONE 1-800-519-3456**

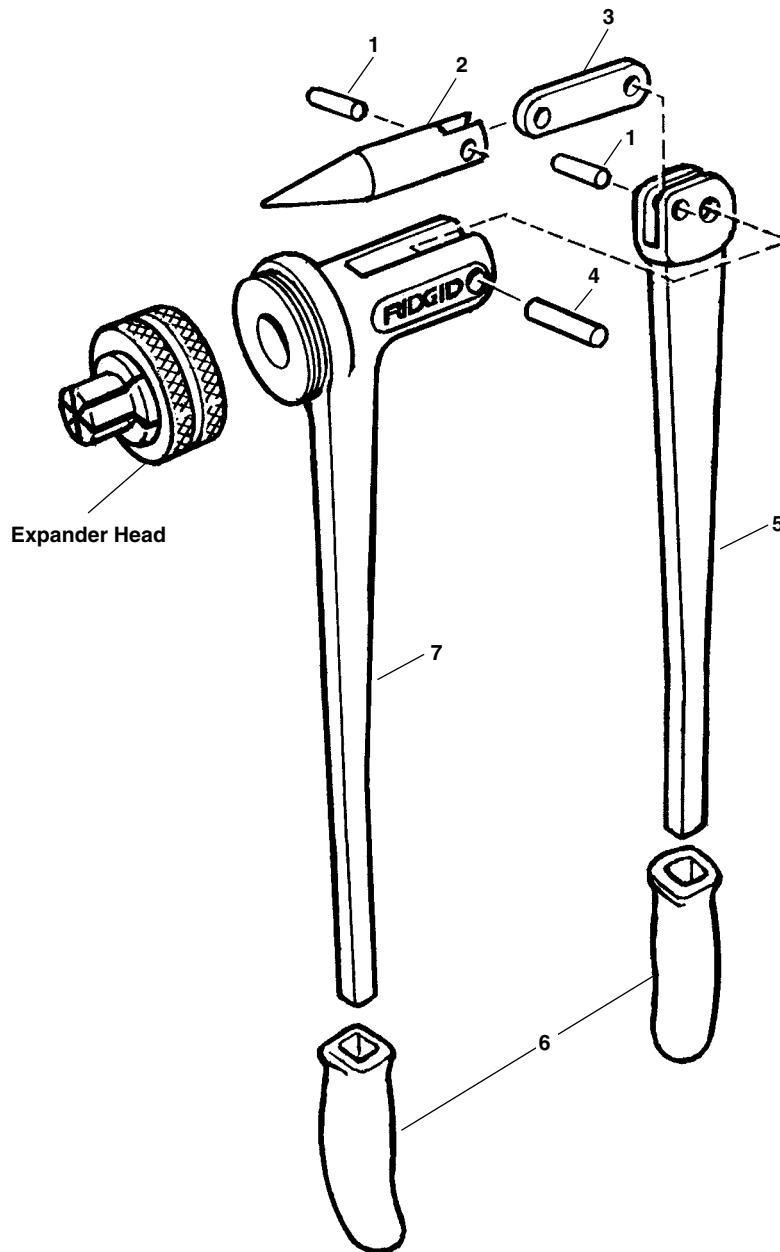

**NOTE: Order parts by Catalog Number only.
DO NOT order by Reference Number.**

Ref. No.	Catalog No.	Description
—	15071	Model S Expander
1	20136	Dowel Pin
2	20106	Drive Pin
3	20116	Link
4	20126	Pivot Pin
5	20086	Cam Handle
6	20036	Plastic Handle
7	20096	Body

Note: Refer to Tool Price list when ordering expander heads

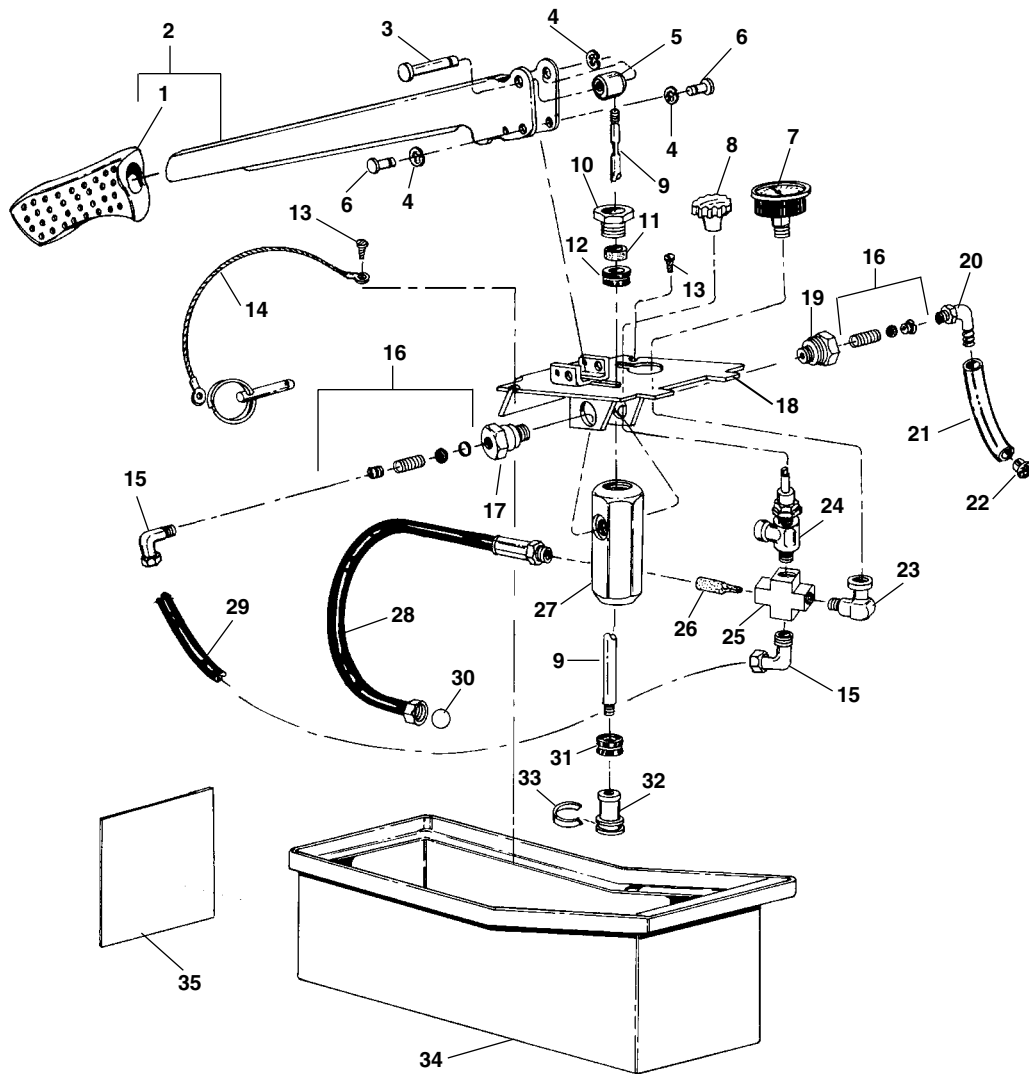

**NOTE: Order parts by Catalog Number only.
DO NOT order by Reference Number.**

Ref. No.	Catalog No.	Description	Ref. No.	Catalog No.	Description	Ref. No.	Catalog No.	Description
—	50557	1450 Test Pump - NPT	12	51132	Rod Seal	24	58002	Needle Valve (Includes Ref. No. 8)
—	50072	1450 Test Pump - BSPT	13	51072	#8 Screw	25	51172	Brass Cross
1	51212	Hand Grip	14	51092	Lock Pin Cable	26	51207	Pressure Strainer
2	51217	Handle w/Grip	15	51112	Rt. Angle Connector	27	51032	Cylinder
3	51052	Rod Pin	16	59217	Valve Repair Kit (Includes Ref. No. 16)	28	51197	Pressure Hose - NPT
4	51062	Retaining Clip	17	59207	Output Valve Assembly (Includes Ref. No. 16)		51227	Pressure Hose - BSPT
5	51042	Rod Holder	18	51107	Top Cover	29	51117	Plastic Tube
6	51057	Handle Pin	19	59212	Intake Valve Assembly (Includes Ref. No. 16)	30	54812	Pressure Hose Washer
7	51152	750 PSI Gauge	20	51067	Right Angle Fitting	31	51127	Piston Seal
	51222	60 Bar Gauge	21	51182	Suction Hose	32	51047	Piston
8	51387	Needle Valve Knob	22	51202	Suction Strainer	33	51122	Piston Guide
9	51097	Piston Rod	23	51147	Street Elbow	34	51162	Reservoir
10	51167	Rod Guide Holder				35	51102	Schematic Label
11	51177	Rod Guide						

915

Drive Roll

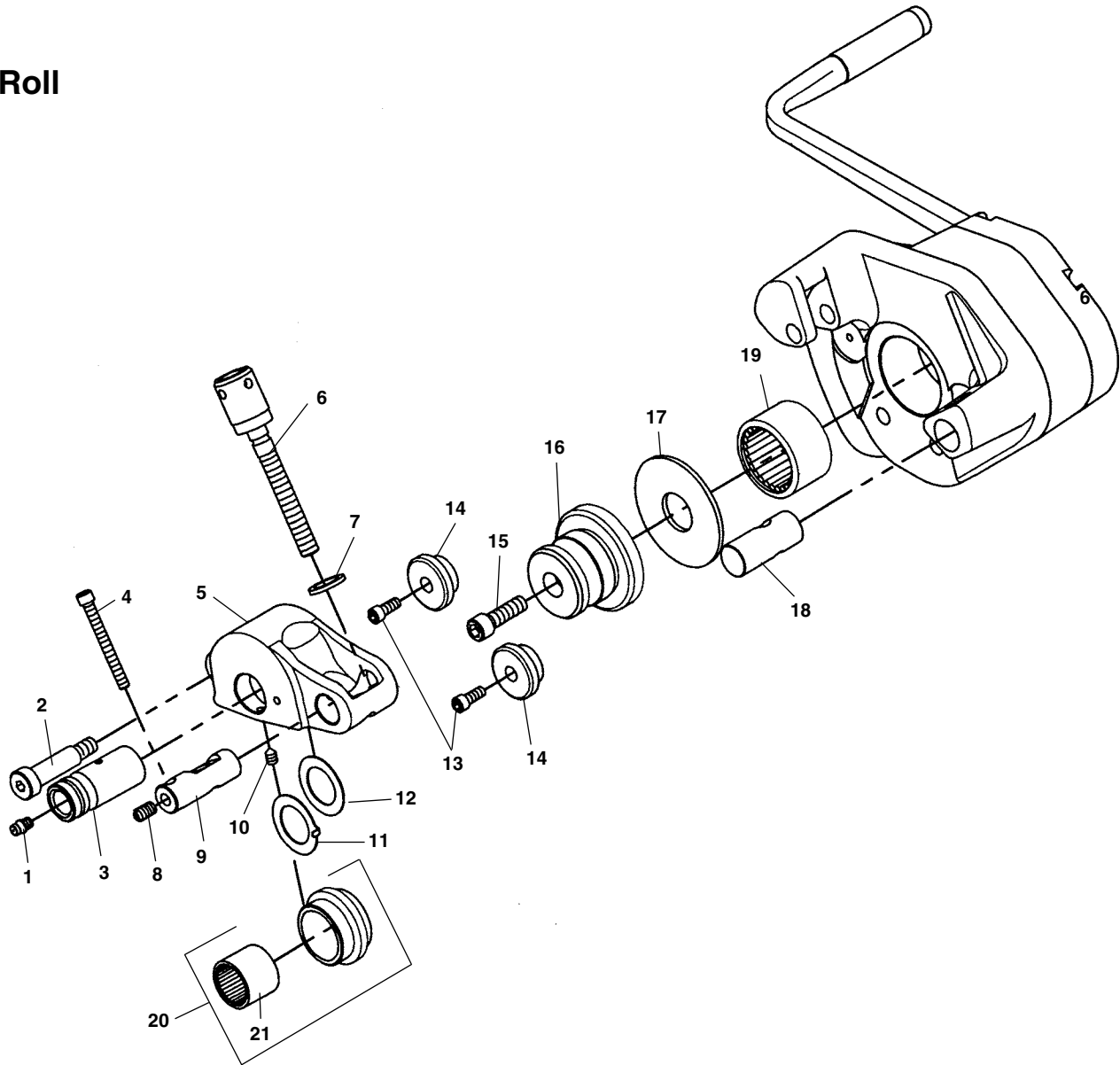

**NOTE: Order parts by Catalog Number only.
DO NOT order by Reference Number.**

Ref. No.	Catalog No.	Description	Ref. No.	Catalog No.	Description
—	88232	915 Roll Groover	12	93652	Thrust Washer
1	46860	Grease Fitting (2)	13	32205	Screw, 1/4" - 20 x 5/8"
2	93602	Shoulder Screw	14	93752	Stabilizer, 2" - 6" (2)
3	93607	Groove Roll Pin		93867	Stabilizer, 8" - 12" (2)
4	93622	Screw, Socket Head, 1/4" - 20 x 2 1/4" (1)	15	46745	Hex Soc Cap Screw 3/8" - 16 x 1 1/4" (1)
5	93627	Reaction Arm	16	93757	Drive Roll 2" - 6" Sch. 10, 2" - 3 1/2" Sch. 40
6	93632	Feed Screw	17	93762	Drive Roll Thrust Washer
7	93657	Load Thrust Washer	18	93767	Pivot Nut Pin
8	93612	Ball Detente, 5/16" - 18 (1)	19	87610	Bearing, Roller
9	93617	Pivot Pin	20	93642	Groove Roll 2" - 6" Sch. 10, 2" - 3 1/2" Sch. 40
10	45192	Set Screw, Socket Head	21	45172	Bearing
11	93647	Locking Thrust Washer			

915

Main Housing

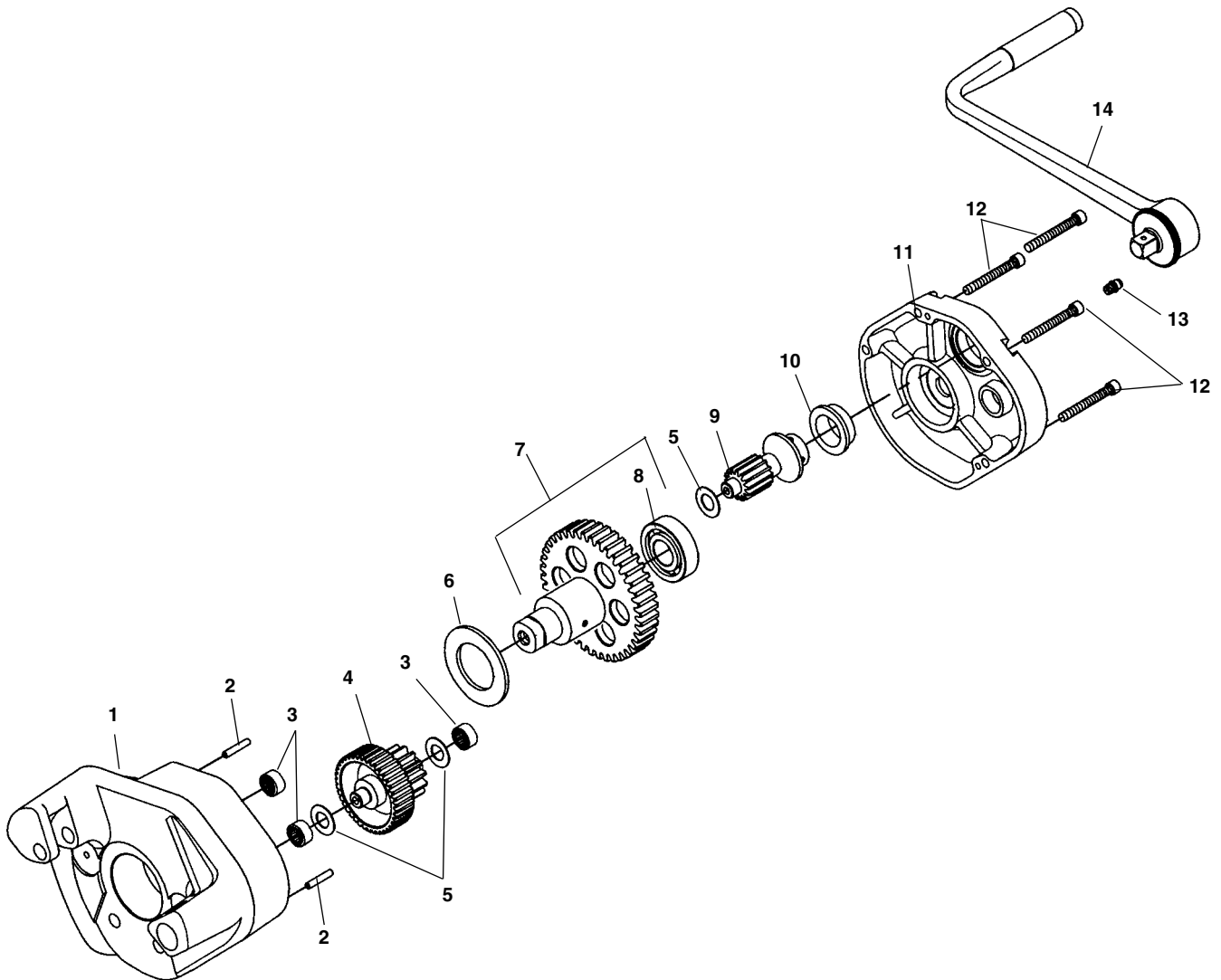

**NOTE: Order parts by Catalog Number only.
DO NOT order by Reference Number.**

Ref. No.	Catalog No.	Description	Ref. No.	Catalog No.	Description
1	93772	Main Housing	8	44620	Bearing, Ball
2	77097	Pin (4)	9	93807	Input Drive Pinion
3	93777	Needle Roller Bearing (3)	10	93812	Bronze Flange Bearing
4	93787	Intermediate Gear Cluster	11	93817	Rear Cover
5	93782	Thrust Bearing Washer (3)	12	40657	Screw, 1/4" - 20 x 1 1/2" (4)
6	93792	Bronze Thrust Bearing	13	46860	Drive Grease Fitting (2)
7	16408	Drive Shaft Assembly	14	92202	Ratchet, 1/2" Drive 90°

915

Accessories

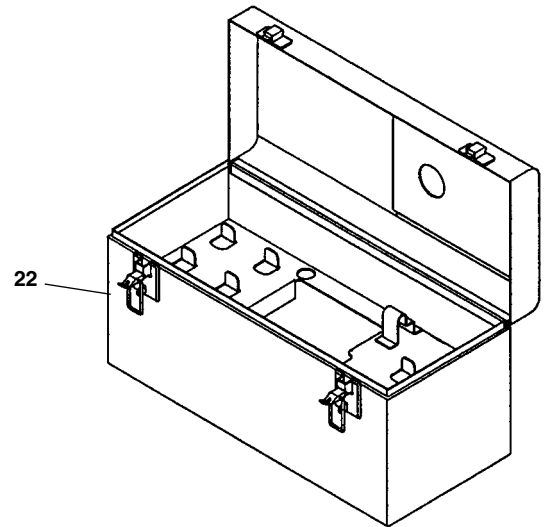
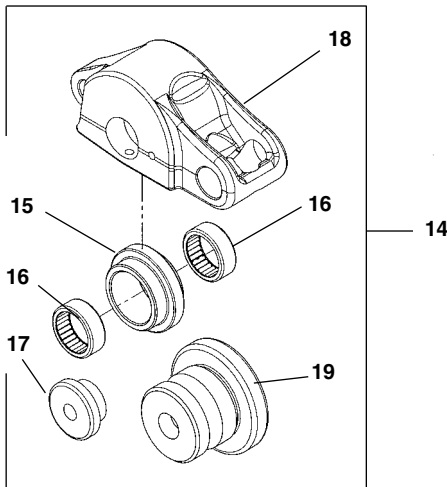
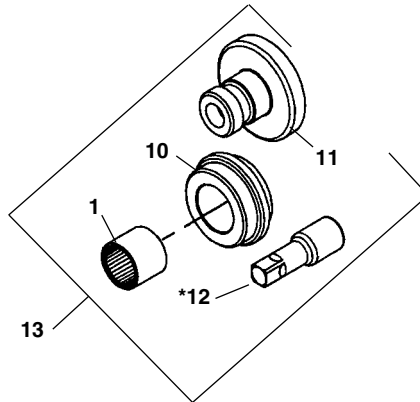
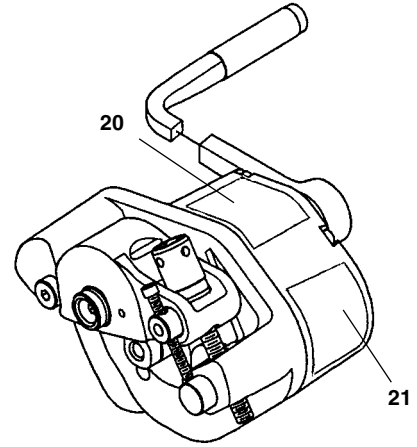
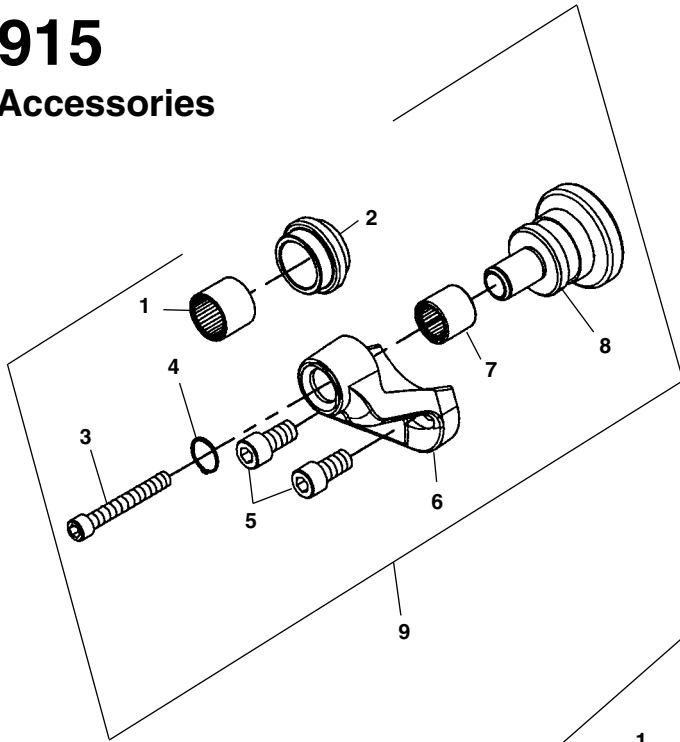

**NOTE: Order parts by Catalog Number only.
DO NOT order by Reference Number.**

Ref. No.	Catalog No.	Description	Ref. No.	Catalog No.	Description
1	45172	Bearing	13	92437	1 1/4" - 1 1/2" Groove Roll Set
2	93887	Groove Roll 4" - 6" Sch. 40	14	92452	2" - 8" Copper 915 Groove Roll Set
	93862	Groove Roll 8" - 12" Sch. 10	15	93892	Copper Groove Roll 2" - 8"
3	93847	Screw 3/8" - 16 x 2 3/4"	16	10368	Bearing Needle Roller (2)
4	93852	External Retaining Ring	17	10373	Copper Stabilizer
5	93857	Screw, 1/2" - 12 x 1" (2)	18	10378	Copper Reaction Arm
6	93872	Support, Drive Roll	19	93897	Copper Drive Roll 2" - 8"
7	93877	Bearing, Needle Roller	20	93822	Operating Instructions Decal
8	93902	Drive Roll 4" - 6" Sch. 40	21	93827	Warning Decal
	93882	Drive Roll 8" - 12" Sch. 10	22	93497	915 Tool Box
9	92447	4" - 6" Sch. 40 Groove Roll Set	* Note Items Not Shown		
	92442	8" - 12" Sch. 10 Groove Roll Set	*	49087	1/8" T-Handle Hex Key
10	93837	Groove Roll 1 1/4" - 1 1/2"	*	46045	5/16" Hex Key
11	93832	Drive Roll 1 1/4" - 1 1/2"	*	46030	3/16" Hex Key
12	93842	Extension, 1/2" Drive (for 1 1/4" - 1 1/2" Roll Set)	*	46190	1/4" Hex Key

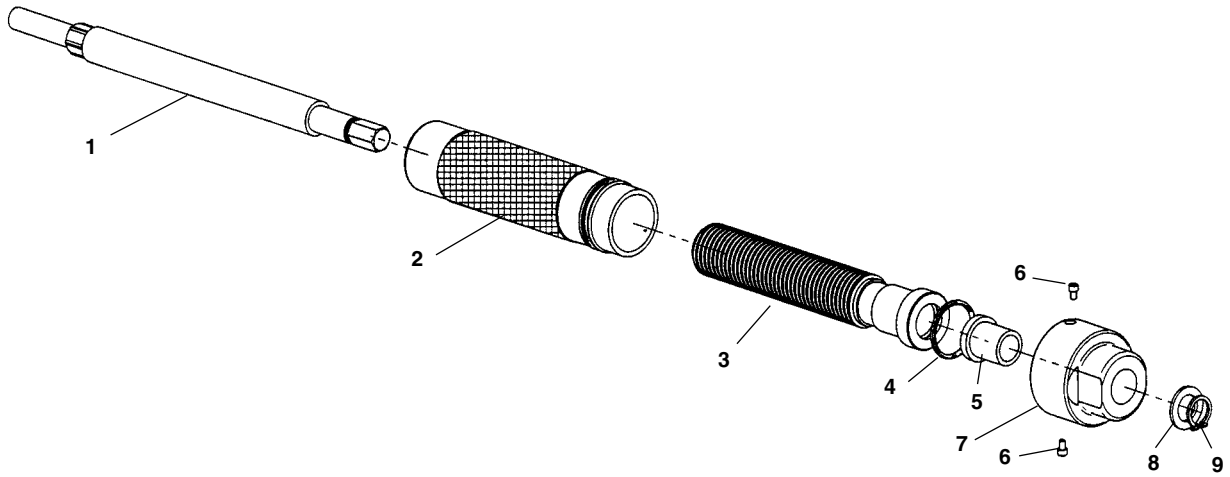

**NOTE: Order parts by Catalog Number only.
DO NOT order by Reference Number.**

Ref. No.	Catalog No.	Description
1	83947	Spindle
2	83952	Sleeve
3	83957	Bronze Screw
4	83962	O-Ring
5	83967	Flanged Bushing
6	83992	8-32 x 1/4" SHCS (2)
7	83972	End Cap
8	76407	Thrust Washer
9	76412	Retaining Ring

Direct Tap Assembly

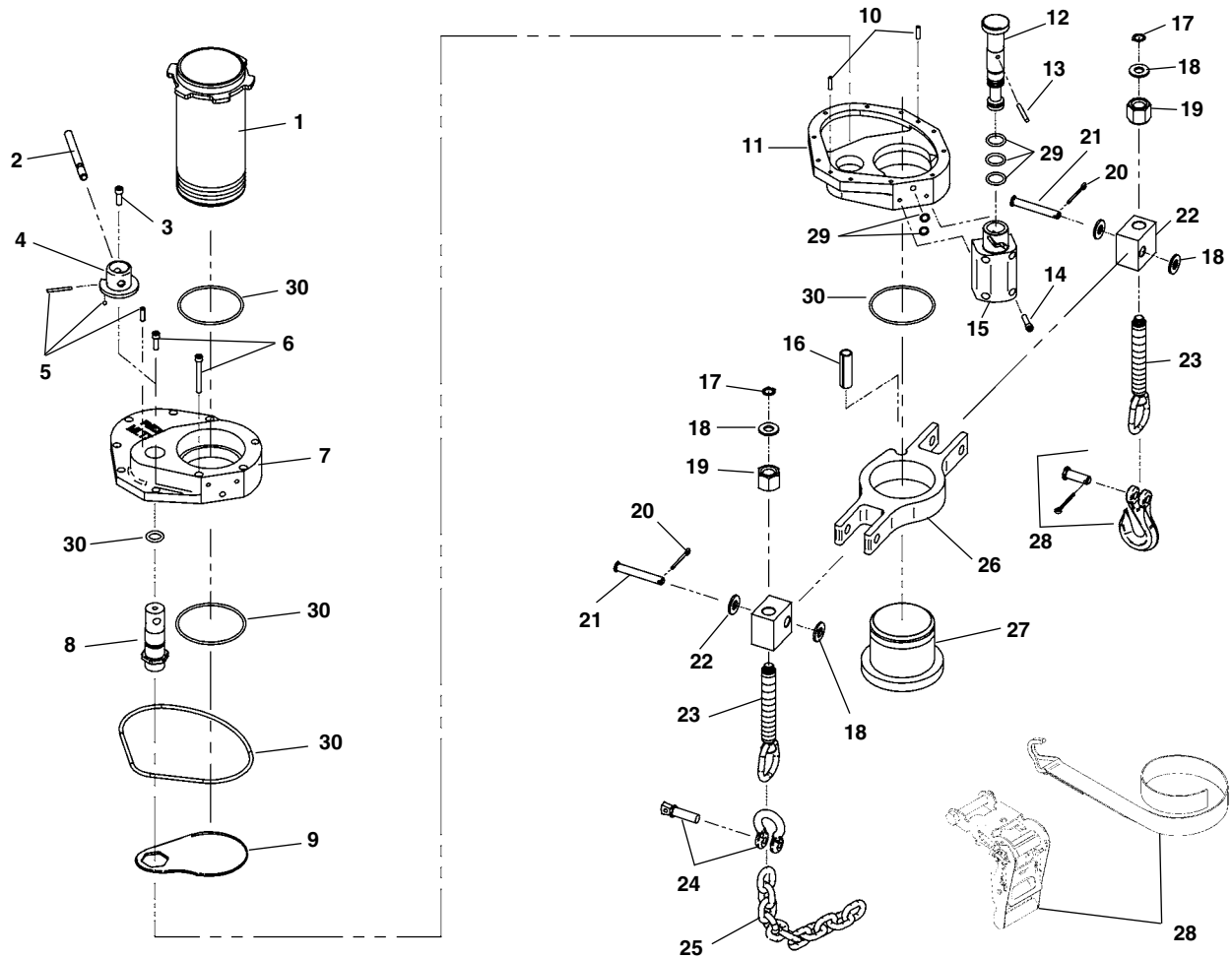

**NOTE: Order parts by Catalog Number only.
DO NOT order by Reference Number.**

Ref. No.	Catalog No.	Description	Ref. No.	Catalog No.	Description
1	92982	Top Cylinder	16	93062	Roll Pin, $\frac{3}{16}$ " x 1"
2	92992	Valve Stem Handle	17	93152	Retaining Ring (2)
3	93082	Set Screw, $\frac{1}{4}$ " - 28 x $\frac{3}{8}$ "	18	93132	Flat Washer (6)
4	93107	Gate Plate	19	63162	Clamp Nut (2)
5	93087	Ball, Spring, Pin	20	93127	Cotter Pin (2)
6	93072	Screw Kit, $\frac{1}{4}$ " - 20 x $\frac{3}{4}$ ", $\frac{1}{4}$ " - 20 x 2" (10)	21	93137	Clevis Pin (2)
7	93012	Upper Valve Chamber	22	93142	Mounting Block
8	93087	Valve Stem	23	93147	Chain Yoke (2)
9	93037	Valve Gate	24	93172	Shackle w/Pin
10	93067	Dowel Pin, $\frac{3}{16}$ " x $\frac{3}{4}$ " (2)	25	93167	Chain
11	93017	Lower Valve Chamber	26	93057	Chain Mount
12	92997	Equalizer Valve Piston	27	93007	Saddle Mount Valve Chamber
13	92952	Roll Pin, $\frac{3}{16}$ " x 1"	28	92047	PVC Strap Mount Assembly
14	92957	Soc. Hd. Cap Screw, $\frac{1}{4}$ " - 20 x 1" (4)	29	93042	O-Ring Kit, Equalizing Valve
15	93002	Equalizing Valve Body	30	93027	O-Ring Kit, Upper Valve Chamber

Saddle Tap Assembly

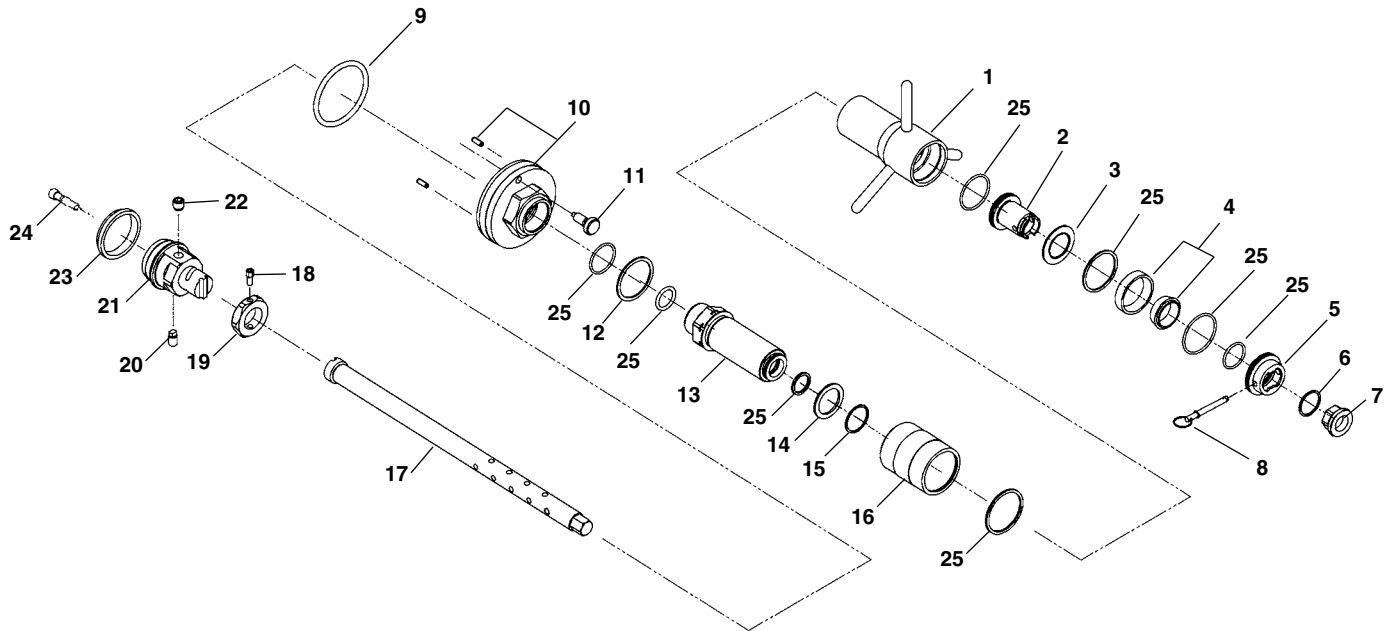

**NOTE: Order parts by Catalog Number only.
DO NOT order by Reference Number.**

Ref. No.	Catalog No.	Description	Ref. No.	Catalog No.	Description
1	92907	Adjusting Nut Assembly	14	92902	Stop Washer
2	92887	Thrust Sleeve	15	92897	Retaining Ring
3	92967	Washer	16	92927	Thread Guard
4	92872	Roller Bearing Set	17	92937	Shaft Assembly
5	92852	Thrust Collar	18	93192	Set Screw
6	92847	Retaining Ring	19	93187	Hex Nut
7	92842	Cap Nut	20	93197	Set Screw Driver
8	92877	Quick Release Pin	21	83182	Tool Holder Body
9	93022	O-Ring	22	93202	Drill Holder Screw
10	92972	Cap w/Roll Pins	23	93207	Guide Ring
11	92947	Plunger	24	93177	Soc. Hd. Cap Screw, 3/8" - 24 x 2"
12	92932	Retaining Ring	25	92857	O-Ring/Wiper Ring Kit
13	92917	Adjusting Screw			

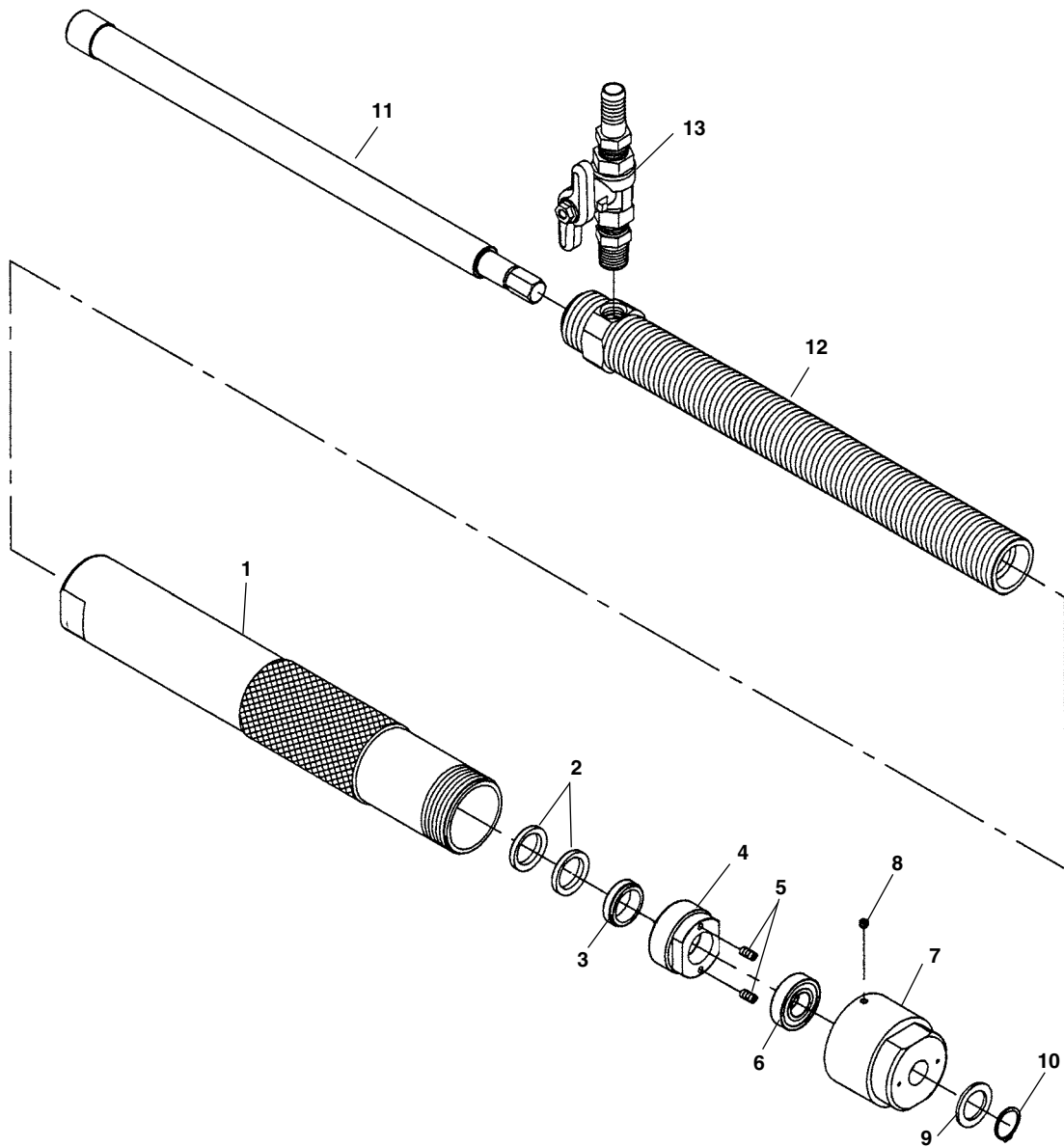

**NOTE: Order parts by Catalog Number only.
DO NOT order by Reference Number.**

Ref. No.	Catalog No.	Description	Ref. No.	Catalog No.	Description
—	75982	RT3422 Tapping Tool	7	76362	End Cap
1	76357	Sleeve	8	76367	Set Screw
2	76392	Graphite Seals	9	76407	Thrust Washer
3	76382	Seal Ring	10	76412	Retaining Ring
4	76387	Seal Cap	11	76372	Shaft
5	76397	Set Screw 1/4" - 20 x 1/2"	12	76377	Feed Screw
6	76402	Bearing	13	76977	Bleed Valve



Pipe For 141 Geared Pipe Threaders

Die Material or Type		Catalog Numbers	
		(NPT) National Pipe Taper 2 1/2" Thru 4"-8 TPI	(BSPT) British Standard Pipe Taper 2 1/2" Thru 4"-11 TPI
High Speed	RH	38120	*66625
H.S. For Stainless Steel	RH	70640	*70645
H.S. For Cast Iron	RH	38125	-
Carbide Tip For Chemtite	RH	38135	-

(NPSM) National Pipe Straight Mechanical-Use (NPT) Dies and Rotate Threader Guide Post 180°
 (BSPP) British Standard Pipe Parallel-Use (BSPP) Dies and Rotate Threader Guide Post 180°



Pipe Dies For 161 Geared Pipe Threaders

Die Material or Type		Catalog Numbers	
		(NPT) National Pipe Thread 4" Thru 6"-8 TPI	(BSPT) British Standard Pipe Taper 4" Thru 6"-11 TPI
High Speed	RH	38155	*66620
H.S. For Stainless Steel	RH	70655	-

(NPSM) National Pipe Straight Mechanical-Use (NPT) Dies and Rotate Threader Guide Post 180°
 (BSPP) British Standard Pipe Parallel-Use (BSPP) Dies and Rotate Threader Guide Post 180°

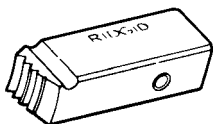

Pipe Dies For 4PJ Geared Pipe Threaders

Die Material or Type		Catalog Numbers							
		(NPT) National Pipe Taper				(NPSM) National Pipe Straight Mechanical* (1)			
		Nominal Pipe Size-Threads Per Inch				Nominal Pipe Size-Threads Per Inch			
High Speed	RH	38220	38225	38230	38235	46732	46737	46742	46747
H.S. For Cast Iron	RH	38240	38245	-	-	-	-	-	-

Die Material or Type		(BSPT) British Standard Pipe Taper*			
		Nominal Pipe Size-Threads Per Inch			
		2 1/2"-11	3"-11	3 1/2"-11	4"-11
High Speed	RH	*66535	*66540	-	-

* Requires BSPT Threader
 (1) Requires NPSM Threader

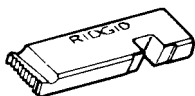

Pipe Dies For 504 Quick Opening Threader

Die Material or Type		Catalog Numbers	
		(NPT) National Pipe Thread 1" Thru 2"-11 1/2 TPI	(NPSM) National Pipe Straight Mechanical 1" Thru 2"-11 1/2 TPI
High Speed	RH	47750	-
H.S. For Stainless Steel	RH	47770	47860
H.S. For Stainless Steel	RH	47790	-

Pipe Dies For 00-R, 111-R, 12R, 0-R, 11-R Ratchet Threaders or 30A, 31A, 3-Way Pipe Threaders

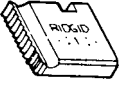
			Catalog Numbers								
Die Material or Type			Nominal Pipe Size – Threads Per Inch								
(NPT) National Pipe Taper			1/8"-27	1/4"-18	3/8"-18	1/2"-14	3/4"-14	1"-11 1/2	1 1/4"-11 1/2	1 1/2"-11 1/2	2"-11 1/2
	Alloy	RH	37810	37815	37820	37825	37830	37835	37840	37845	37850
	High Speed	RH	37855	37860	37865	37870	37875	37880	37885	37890	37895
	High Speed	LH	38045	38050	38055	38060	38065	38070	38075	38080	38085
	H.S. For Stainless Steel	RH	37900	37905	37910	37915	37920	37925	37930	37935	37940
	H.S. For PVC	RH	–	–	70685	70690	70695	70700	70705	70710	70715
(NPSM) National Pipe Straight Mechanical			1/8"-27	1/4"-18	3/8"-18	1/2"-14	3/4"-14	1"-11 1/2	1 1/4"-11 1/2	1 1/2"-11 1/2	2"-11 1/2
	Alloy	RH	37945	37950	37955	39760	37965	37970	37975	37980	37985
	Alloy	LH	–	–	–	–	–	37990	–	37995	–
(BSPT) British Standard Pipe Taper*			1/8"-28	1/4"-19	3/8"-19	1/2"-14	3/4"-14	1"-11	1 1/4"-11	1 1/2"-11	2"-11
	Alloy	RH	66110	66115	66120	66125	66130	66135	66140	66145	66150
	High Speed	RH	66310	66315	66320	66325	66330	66335	66340	66345	66350
	High Speed	LH	66405	66410	66415	66420	66425	66430	66435	–	66445
(BSPP) British Standard Pipe Parallel*			1/8"-28	1/4"-19	3/8"-19	1/2"-14	3/4"-14	1"-11	1 1/4"-11	1 1/2"-11	2"-11
	Alloy	RH	66190	66195	66200	66205	66210	66215	66220	66225	66230
			Nominal Conduit Size in mm – Threads Pitch in mm								
(ISO) International Standards Organization			16-1.5	20-1.5	25-1.5	32-1.5	40-1.5				
	Alloy	RH	–	85830	76305	85835	76315				
			Nominal Conduit Size – Threads Per Inch								
(BEC) British Electrical Conduit (1)			1/2"-18	5/8"-18	3/4"-16	1"-16	1 1/4"-16	1 1/2"-14			
	Alloy	RH	66155	66160	66165	66170	66175	–			

Bolt Threaders Button Dies For 00-RB Ratchet Bolt Threaders or 31B, 33B, 35B, 37B 3-Way Bolt Threaders

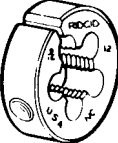
			Catalog Numbers									
			Rod Diameter – Threads Per Inch									
(UNC) Unified National Course			1/4"-20	5/16"-18	3/8"-16	7/16"-14	1/2"-13	9/16"-12	5/8"-11	3/4"-10	7/8"-9	1"-8
	Alloy	RH	38335	38340	38345	38350	38355	38360	38365	38370	38375	38380
(UNC) Unified National Fine			1/4"-28	5/16"-24	3/8"-24	7/16"-20	1/2"-20	9/16"-18	5/8"-18	3/4"-16	7/8"-14	1"-12
	Alloy	RH	38385	38390	38395	38400	38405	38410	38415	38420	38425	15317

*1" – 14NS RH-38430; LH38530

Receding Threaders Pipe Dies For 65R-C & 65R-TC Ratchet Threaders

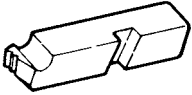
			Catalog Numbers	
Die Material or Type			(NPT) National Pipe Taper	(BSPT) British Standard Pipe Taper
			1" Thru 2"-11 1/2 TPI	1" Thru 2"-11 TPI
	High Speed	RH	38100	*66450
	H.S. For Stainless Steel	RH	38105	–
	H.S. For Cast Iron	RH	38110	–



* Requires British Die Head or Threader
(1) Requires BEC Die Head

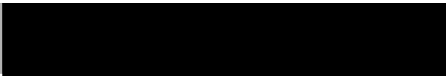

What is covered

RIDGID® tools are warranted to be free of defects in workmanship and material.

How long coverage lasts

This warranty lasts for the lifetime of the RIDGID® tool. Warranty coverage ends when the product becomes unusable for reasons other than defects in workmanship or material.

How you can get service

To obtain the benefit of this warranty, deliver via prepaid transportation the complete product to RIDGE TOOL COMPANY, Elyria, Ohio, or any authorized RIDGID® INDEPENDENT SERVICE CENTER. Pipe wrenches and other hand tools should be returned to the place of purchase.

What we will do to correct problems

Warranted products will be repaired or replaced, at RIDGE TOOL'S option, and returned at no charge; or, if after three attempts to repair or replace during the warranty period the product is still defective, you can elect to receive a full refund of your purchase price.

What is not covered

Failures due to misuse, abuse or normal wear and tear are not covered by this warranty. RIDGE TOOL shall not be responsible for any incidental or consequential damages.

How local law relates to the warranty

Some states do not allow the exclusion or limitation of incidental or consequential damages, so the above limitation or exclusion may not apply to you. This warranty gives you specific rights, and you may also have other rights, which vary, from state to state, province to province, or country to country.

No other express warranty applies

This FULL LIFETIME WARRANTY is the sole and exclusive warranty for RIDGID® products. No employee, agent, dealer, or other person is authorized to alter this warranty or make any other warranty on behalf of the RIDGE TOOL COMPANY.



Technical Service: 800-519-3456

(Product Application Assistance)

**Visit our web sites: www.ridgid.com
and www.ridgidparts.com**

Ridge Tool Company

400 Clark Street

Elyria, Ohio 44035-6001

**Ce qui est couvert**

Les outils RIDGE® sont garantis contre tous vices de matériaux et de main d'oeuvre.

Durée de couverture

Cette garantie est applicable durant la vie entière de l'outil RIDGE®. La couverture cesse dès lors que le produit devient inutilisable pour raisons autres que des vices de matériaux ou de main d'oeuvre.

Pour invoquer la garantie

Pour toutes réparations au titre de la garantie, il convient d'expédier le produit complet en port payé à la RIDGE TOOL COMPANY, Elyria, Ohio, ou bien le remettre à un réparateur RIDGID® agréé. Les clés à pipe et autres outils à main doivent être ramenés au lieu d'achat.

Ce que nous ferons pour résoudre le problème

Les produits sous garantie seront à la discrétion de RIDGE TOOL, soit réparés ou remplacés, puis réexpédiés gratuitement ; ou si, après trois tentatives de réparation ou de remplacement durant la période de validité de la garantie le produit s'avère toujours défectueux, vous aurez l'option de demander le remboursement intégral de son prix d'achat.

Ce qui n'est pas couvert

Les défaillances dues au mauvais emploi, à l'abus ou à l'usure normale ne sont pas couvertes par cette garantie. RIDGE TOOL ne sera tenue responsable d'aucuns dommages directs ou indirects.

L'influence de la législation locale sur la garantie

Puisque certaines législations locales interdisent l'exclusion des dommages directs ou indirects, il se peut que la limitation ou exclusion ci-dessus ne vous soit pas applicable. Cette garantie vous donne des droits spécifiques qui peuvent être éventuellement complétés par d'autres droits prévus par votre législation locale.

Il n'existe aucune autre garantie expresse

Cette GARANTIE PERPETUELLE INTEGRALE est la seule et unique garantie couvrant les produits RIDGID®. Aucun employé, agent, distributeur ou tiers n'est autorisé à modifier cette garantie ou à offrir une garantie supplémentaire au nom de la RIDGE TOOL COMPANY.

Qué cubre

Las herramientas RIDGID están garantizadas contra defectos de la mano de obra y de los materiales empleados en su fabricación.

Duración de la cobertura

Esta garantía cubre a la herramienta RIDGID durante toda su vida útil. La cobertura de la garantía caduca cuando el producto se torna inservible por razones distintas a las de defectos en la mano de obra o en los materiales.

Cómo obtener servicio

Para obtener los beneficios de esta garantía, envíe mediante porte pagado, la totalidad del producto a RIDGE TOOL COMPANY, en Elyria, Ohio, o a cualquier Servicentro Independiente RIDGID. Las llaves para tubos y demás herramientas de mano deben devolverse a la tienda donde se adquirieron.

Lo que hacemos para corregir el problema

El producto bajo garantía será reparado o reemplazado por otro, a discreción de RIDGE TOOL, y devuelto sin costo; o, si aún resulta defectuoso después de haber sido reparado o sustituido tres veces durante el período de su garantía, Ud. puede optar por recibir un reembolso por el valor total de su compra.

Lo que no está cubierto

Esta garantía no cubre fallas debido al mal uso, abuso o desgaste normal. RIDGE TOOL no se hace responsable de daño incidental o consiguiente alguno.

Relación entre la garantía y las leyes locales

Algunos estados de los EE.UU. no permiten la exclusión o restricción referente a daños incidentales o consiguientes. Por lo tanto, puede que la limitación o restricción mencionada anteriormente no rija para Ud. Esta garantía le otorga derechos específicos, y puede que, además, Ud tenga otros derechos, los cuales varían de estado a estado, provincia a provincia o país a país.

No rige ninguna otra garantía expresa

Esta GARANTIA VITALICIA es la única y exclusiva garantía para los productos RIDGID. Ningún empleado, agente, distribuidor u otra persona está autorizado para modificar esta garantía u ofrecer cualquier otra garantía en nombre de RIDGE TOOL COMPANY.



EMERSON. CONSIDER IT SOLVED.™